

Frontier

Free Standing Carport - Installation Guide



1 - BEFORE YOU START

It is important to check your Local Government Authority requirements before the installation of your new Stratco Frontier® Freestanding Carport. Carefully read these instructions and refer to them constantly during each stage of construction. If you do not have all the necessary tools or information contact Stratco for advice. Before starting, lay out all components and check them against the delivery docket. The component description identifies each key part and the component layout diagram indicates their fastening position.

Double check all dimensions, levels and bolting locations before cutting, screwing or bolting structural members. It is recommended that the installers erecting the structure have had some previous building experience.

TOOLS REQUIRED

- Drill & Hex-Head Adaptor
- Rivet Gun
- Tape Measure
- Tin Snips
- Spirit Level
- Hacksaw
- Post Hole Digger
- Silicone Gun
- Spanners or Ratchet
- Adjustable Construction Props
- Concrete
- Ladder

Frontier Freestanding Carport - Installation Guide

Components

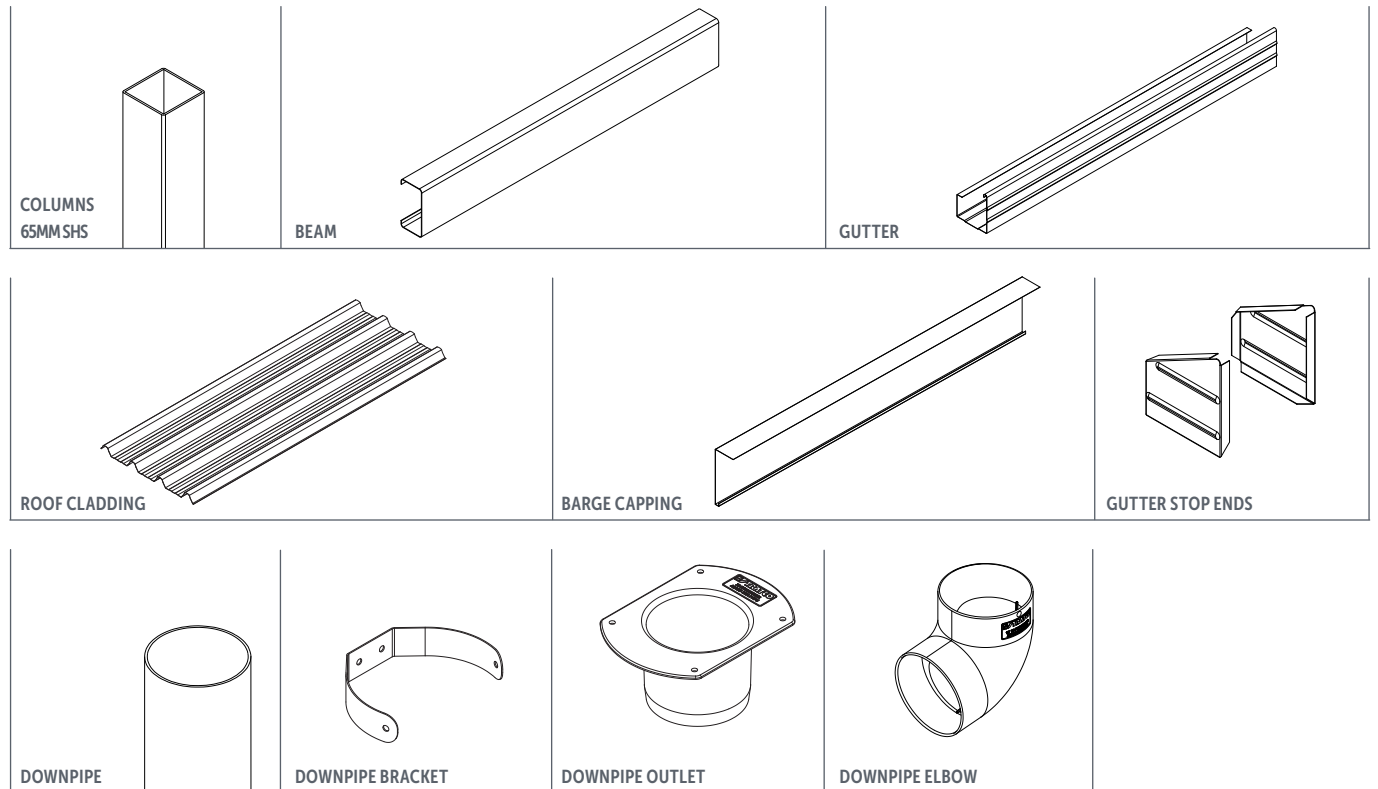

Component Diagram

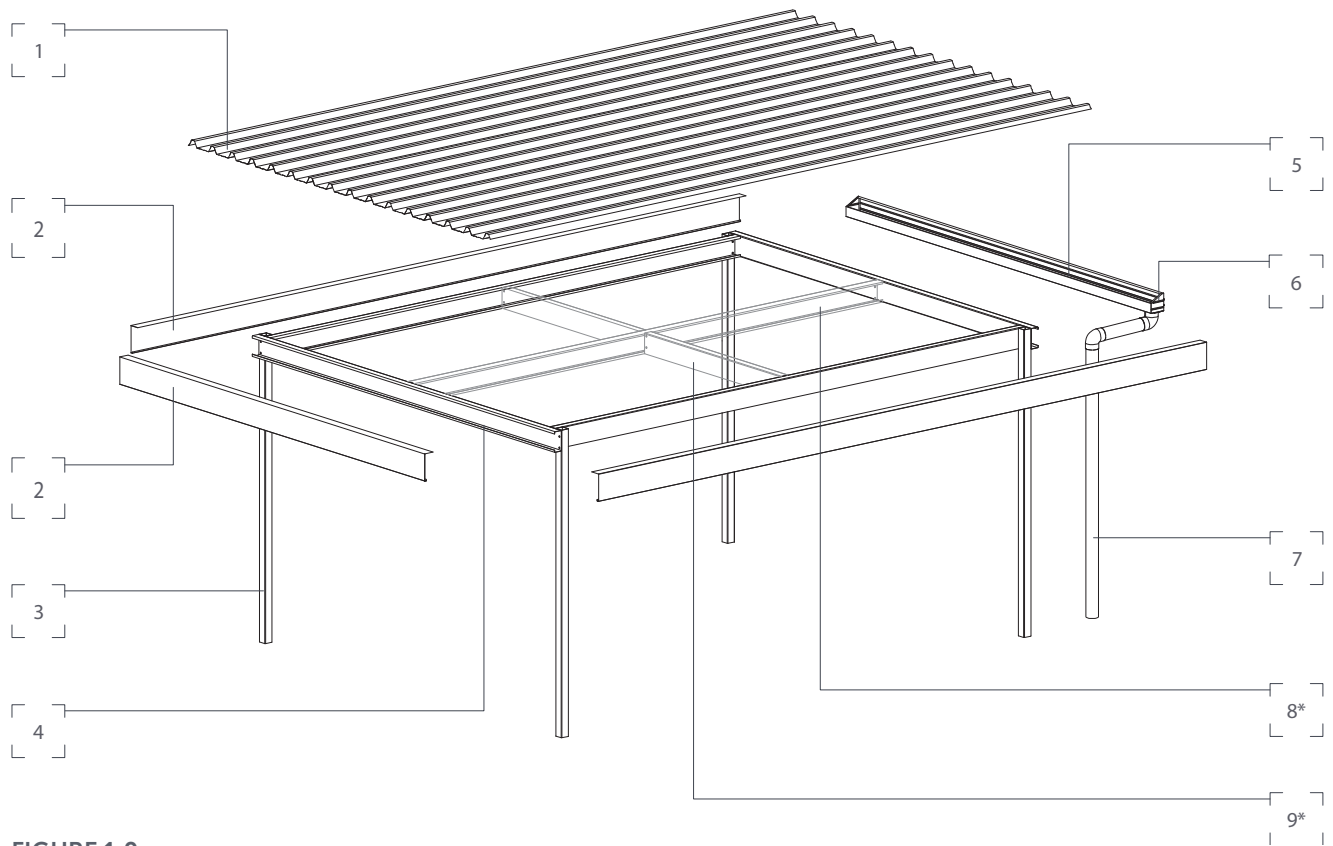

FIGURE 1.0

1. PRODEK ROOFING
2. BARGE CAPPING
3. SHS COLUMN
4. C-SECTION
5. GUTTER
6. GUTTER STOP END
7. DOWNPIPE
8. INTERMEDIATE BEAM - BRIDGING*
9. PURLIN*

***USED ONLY ON SELECT FRONTIER DESIGNS.**

Frontier Freestanding Carport - Installation Guide

2 - Marking Out Carport Position

In Ground Footing

Place stakes at the carport post locations using the appropriate column positions from the supplied drawing.

Note: These post locations are critical, as the roof sheet and beam lengths are governed by these dimensions.

Tie string lines between the stakes to ensure the footings are in line. Check the dimensions and diagonals for squareness.

Dig holes to the required size as stipulated by the supplied drawing. Place bricks in the bottom of the holes to give a solid base onto which the posts can be positioned. Do not concrete columns in place at this stage.

Note: A slight fall (1°) should be allowed for toward one end of the unit at which the gutter and downpipe will be located.

On Concrete Footing

If bolting columns onto an existing concrete slab, check to ensure concrete dimensions allow for the required anchor edge distance and anchor depth as indicated on the supplied drawings. Stratco does not take any responsibility for concrete failure. The builder/owner is responsible for ensuring that the slab is capable of supporting the Frontier® Freestanding Carport.

Mark the position of the columns from the drawings supplied.

Note: These column locations are critical, as the roof sheet and beam lengths are governed by these dimensions.

Check the marks with a string line to ensure the footings are in line. Check the dimensions and diagonals for squareness.

Note: Do not drill through the concrete at this stage. Footing plates are not fixed until the carport frame has been assembled.

3 - Assembling The Framework

Pre-Drill Holes

By following the plan detail on the supplied drawing, locate the perimeter beams.

Note: Lengths will vary between the side beams and the front and rear beams and will depend on the type of carport.

Pre-drill 14mm holes through the C-Section beams and both sides of the SHS columns at the appropriate locations (Figure 3.0). Ensure clearance is provided between holes to avoid bolts interfering.

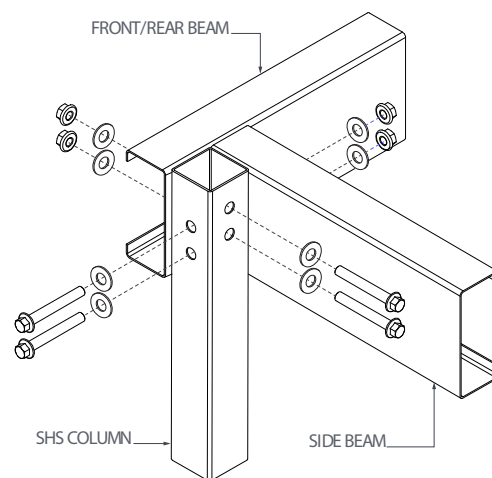

FIGURE 3.0

Locate all of the intermediate beams and purlins if required. Pre-drill 11mm holes at each end of these beams to match the hole locations in the supplied angle brackets (Figure 3.1).

Alternatively, General Purpose Purlin Brackets may be used (which include six holes in the bracket). If this is the case, holes must be pre-drilled to 14mm.

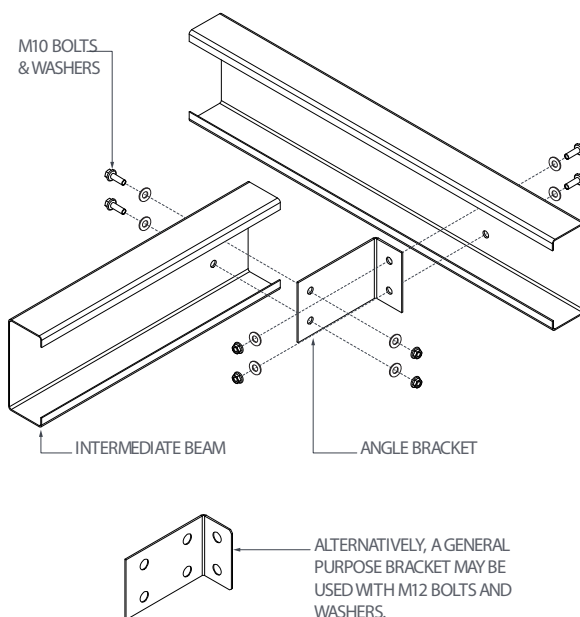

FIGURE 3.1

Note: The type of carport will determine whether or not intermediate beams and purlins are present. Figure 1.0 indicates how to identify intermediate beams and purlins.

Note: Before pre-drilling any holes it is recommended a smaller pilot hole be drilled to make the job easier.

Columns

Stand the columns in the appropriate footing locations and brace with clamps and struts (Figure 3.2)

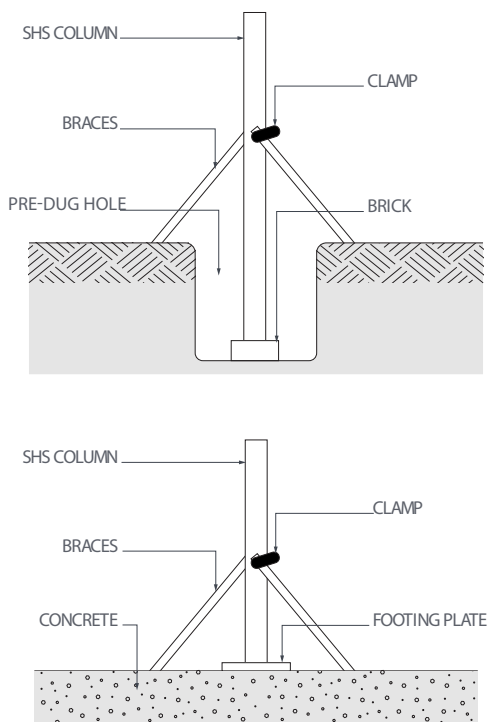

FIGURE 3.2

Note: For both into concrete and onto concrete carports, columns will need to be cut to allow for a 1° fall towards the gutter and the downpipe end.

Perimeter Beams

Bolt holes should have been pre-drilled at the ends of the perimeter beams.

Lift the perimeter beams into place and support on adjustable construction props. Bolt these beams to the columns using the M12 bolts and washers supplied (Figure 3.0).

Note: The side beams should sit on the inside face of the columns while the front and rear beams should sit on the outside face of the columns.

Intermediate Beams

If intermediate beams and purlins are required, bolt holes should be pre-drilled at each end to match those already present in the supplied angle brackets. Attach an angle bracket to each end of the intermediate beams and purlins using the M10 bolts and washers supplied (Figure 3.1). If General Purpose Brackets have been supplied, use M12 bolts and washers.

The supplied drawing will indicate the location of all internal beams. Lift into position and support on adjustable construction props.

If required, drill 11mm holes (14mm for General Purpose Bracket) at the appropriate locations in the adjoining beams to match the hole locations in the angle brackets. Bolt together using the M10 bolts and washers supplied (Figure 3.1) or the M12 bolts and washers for the General Purpose Bracket (Figure 3.1).

Frontier Freestanding Carport - Installation Guide

4 - Footings

Now that the basic framework has been erected, check all dimensions are correct and the diagonals for squareness. Check that the columns are in line and plumb and that the falls are correct for roof and gutter.

In Ground Footing

Concrete the footings and leave overnight to cure.

Note: The concrete should be finished so that it slopes away from the column, ensuring water runs away from the column (Figure 4.0)

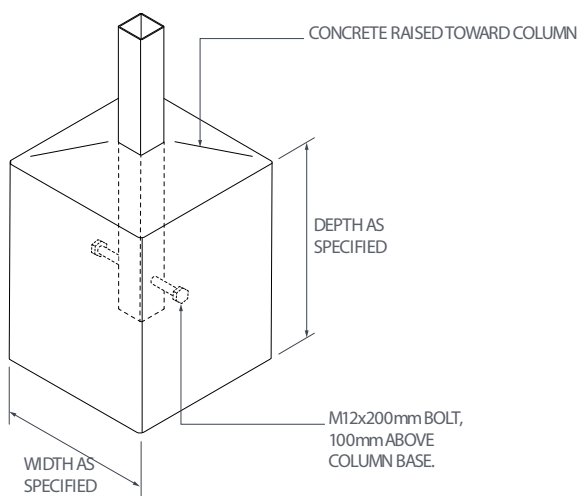

FIGURE 4.0

On Concrete Footing

Mark the position of the holes through the existing holes in the footing plate. Drill 12mm holes to a minimum depth of 100mm.

Fix the footing plates to the concrete slab (minimum 120mm depth) using the 12x100mm Screwbolts supplied, through the pre-drilled holes in the slab (Figure 4.1)

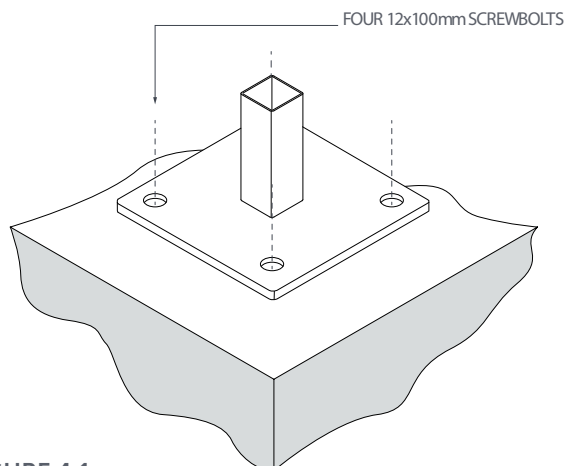

FIGURE 4.1

5 - Roofing

Start laying the roof sheeting from one side of the unit and continue across the unit. Figure 5.0 indicates the laying direction and lapping detail for roof sheeting.

Decking should be positioned to allow an equal deck overhang of 600mm at each end of the unit.

Fix each sheet in place, as specified by the fixing details on the supplied drawing, before laying the next sheet.

Note: Ensure that the sheets are lapped correctly (Figure 5.0).

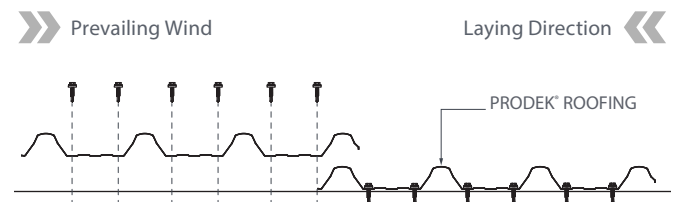

FIGURE 5.0

6 - Guttering

Select where your downpipe will be located and notch a hole in the gutter and insert a downpipe outlet (pop) so that the downpipe is in line with an end column. Fasten the pop in place using rivets and seal with silicone.

Fasten left and right hand gutter stop ends to the lower end of the guttering. Rivet and silicone seal to achieve a waterproof connection.

Fix the length of gutter to the lower end of your carport. Place the return lip at the back end of the guttering underneath the roof sheet, allow for a 50mm overflow into the gutter. Fasten with pop rivets or 10x16mm self drilling screws through the pan of the roof sheets into the return lip on the gutter (Figure 6.0) at maximum 900mm centres.

Fasten Universal Deck Straps in place from the front of the gutter to the roof sheet rib (Figure 6.0) at maximum 900mm centres.

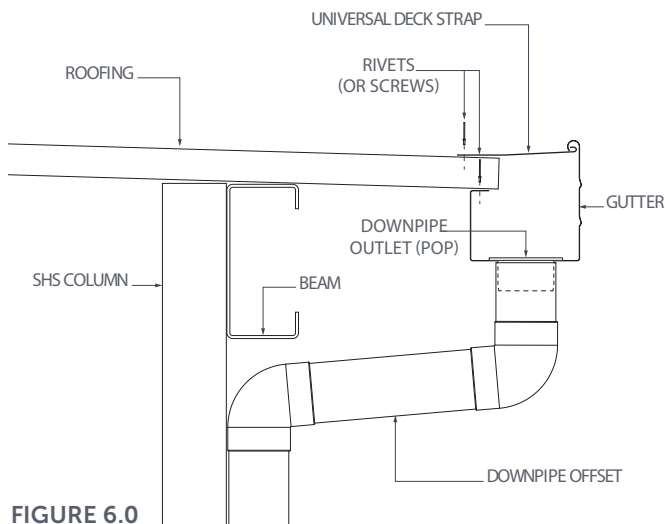

FIGURE 6.0

Cut the downpipe as required to form and offset, using the elbows supplied, attach the PVC downpipe to the downpipe pop and rivet in place. Secure downpipe in position with downpipe straps.

Seal with silicone at all rivet locations to waterproof.

7 - Barge capping

Only the front and two sides of the carport require the attachment of barge capping. The rear has the gutter attached.

Fix the side barge capping first. Position capping flush with the front of the roof sheets and fasten through the top crest of the roof sheets using rivets at 500mm centres (Figure 7.0). Fasten the base of the capping to posts with one 12x35mm self drilling screw. Repeat for the other side of the carport.

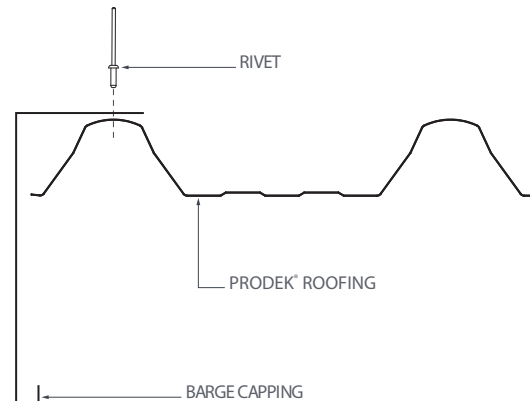

FIGURE 7.0

The front cap is fixed through every third rib and will need to have the return lip on the bottom edge notched using tin snips. This should provide a neat corner joint and can be fastened from below to hold the corner closed using a rivet (Figure 7.1).

Seal with silicone at all rivet locations to waterproof.

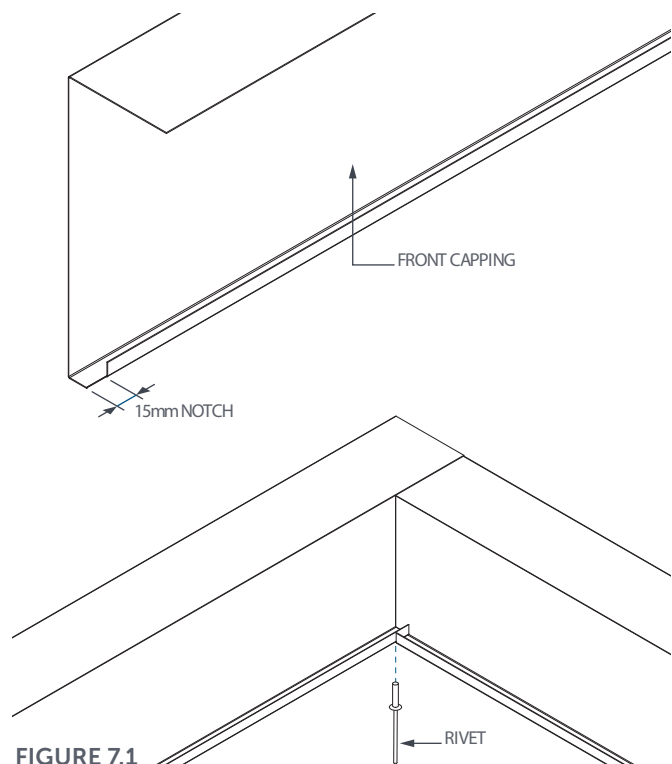
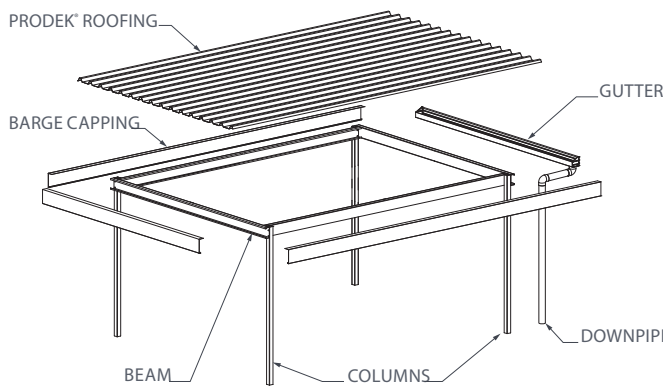

FIGURE 7.1

Frontier Freestanding Carport - Installation Guide

Type 2.0F Single



EXPLODED VIEW

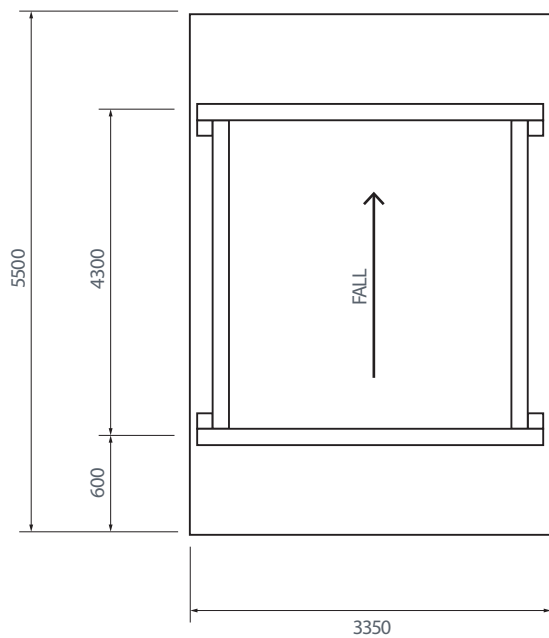

PLAN VIEW

Type 2.0F Double

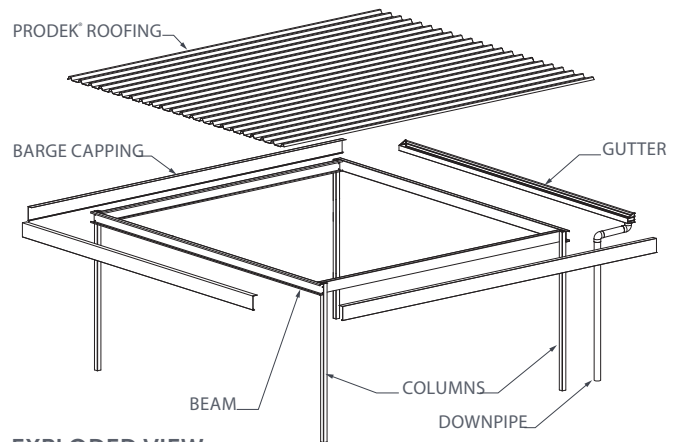

EXPLODED VIEW

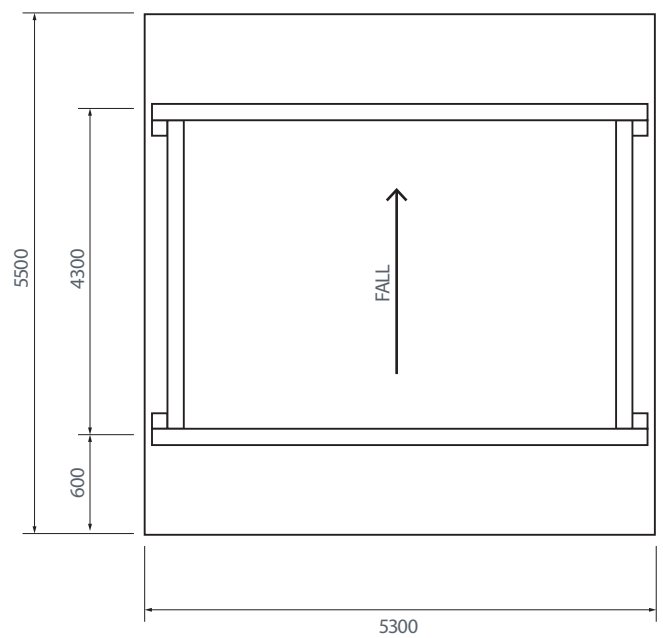

PLAN VIEW

Type 2.1F Single

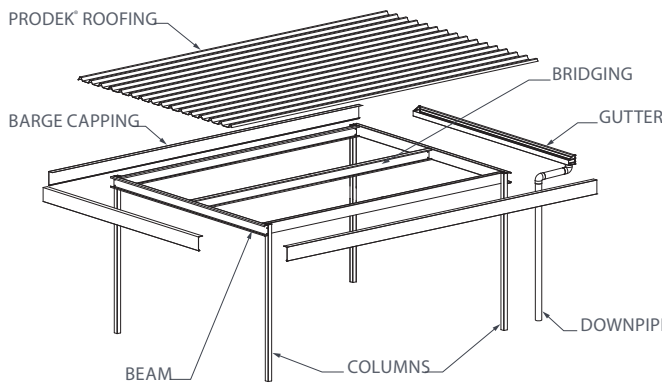

EXPLODED VIEW

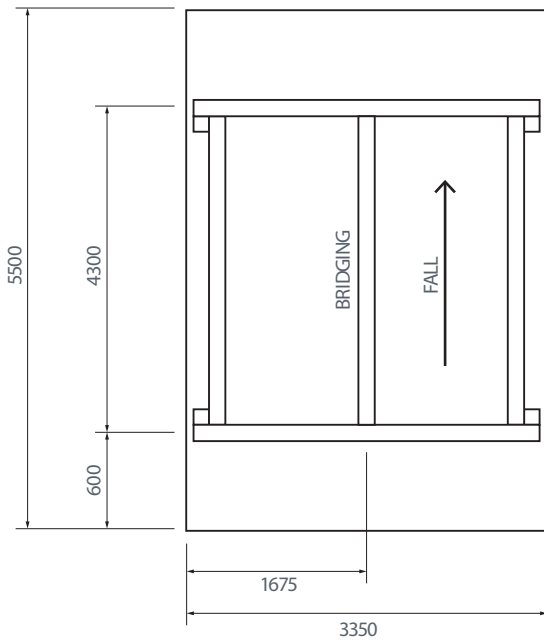

PLAN VIEW

Type 2.1F Double

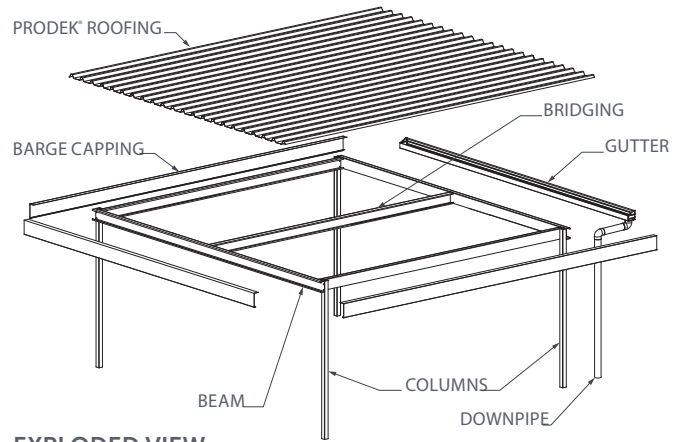

EXPLODED VIEW

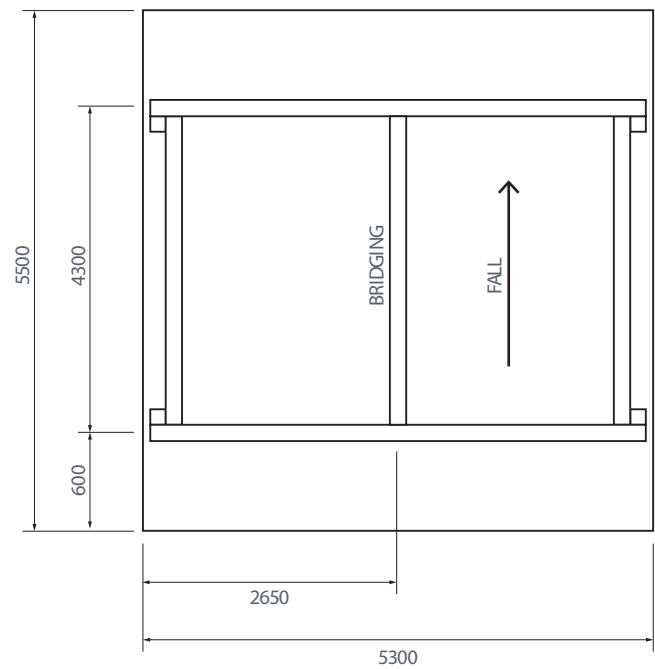

PLAN VIEW

Frontier Freestanding Carport - Installation Guide

Type 3F Single

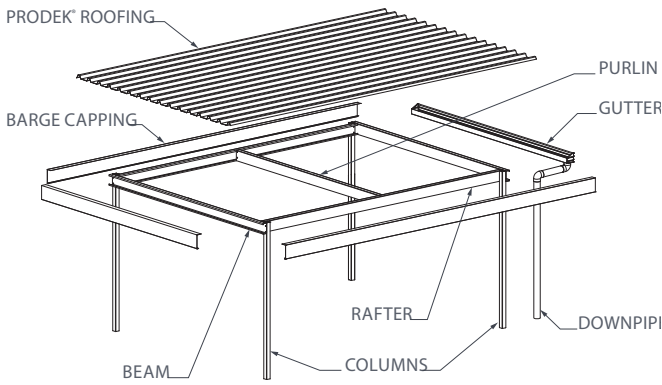

EXPLODED VIEW

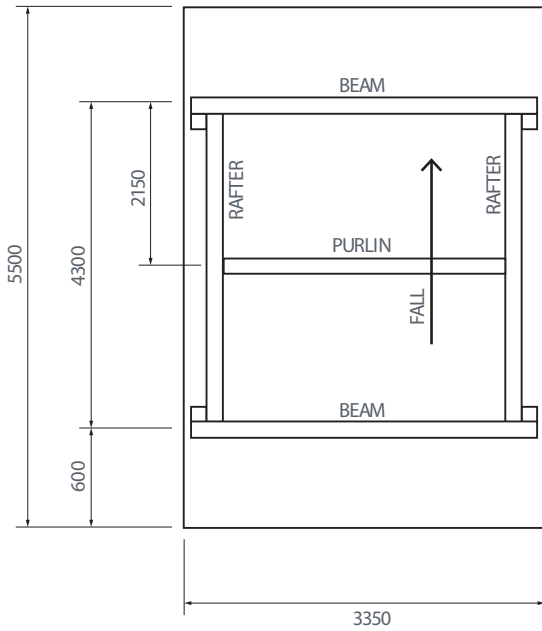

PLAN VIEW

Type 3F Double

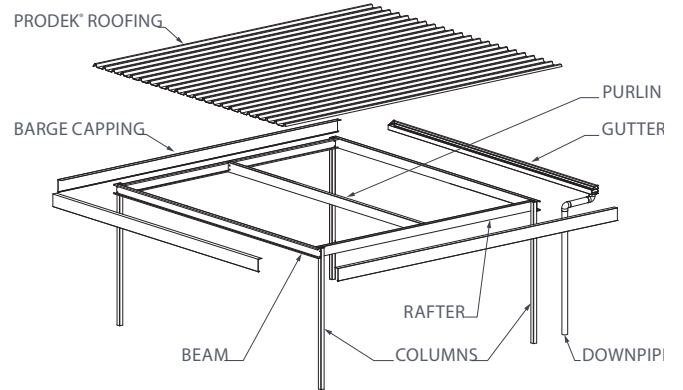

EXPLODED VIEW

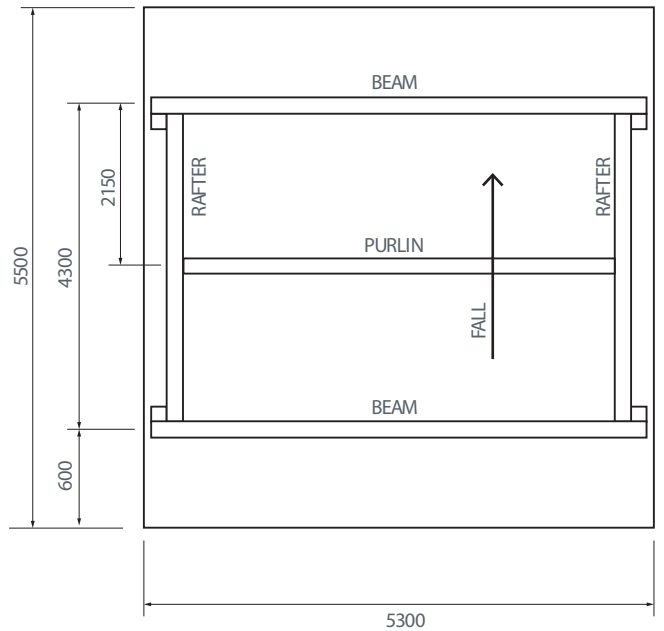

PLAN VIEW

Type 4F Single

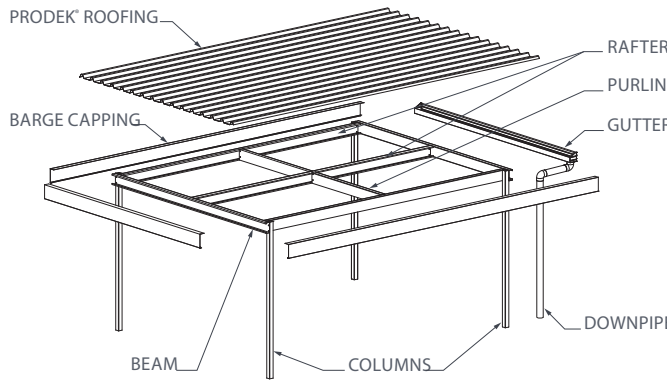

EXPLODED VIEW

Type 4F Double

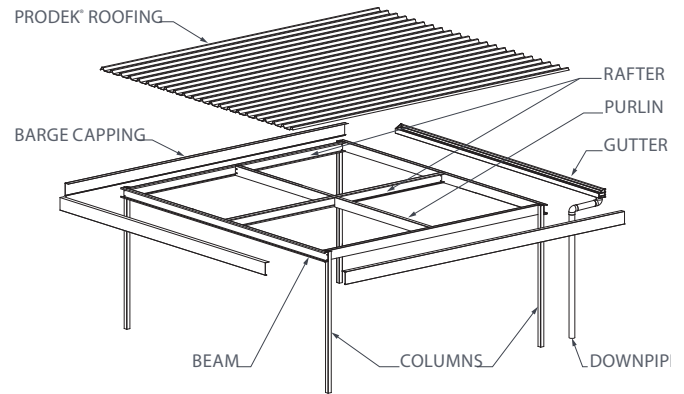

EXPLODED VIEW

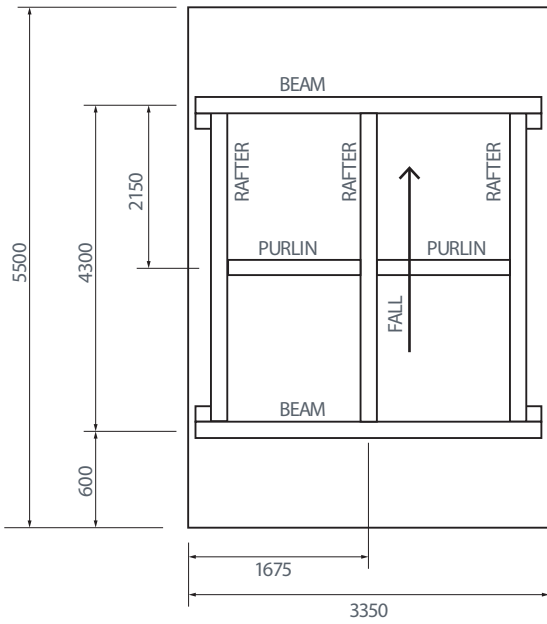

PLAN VIEW

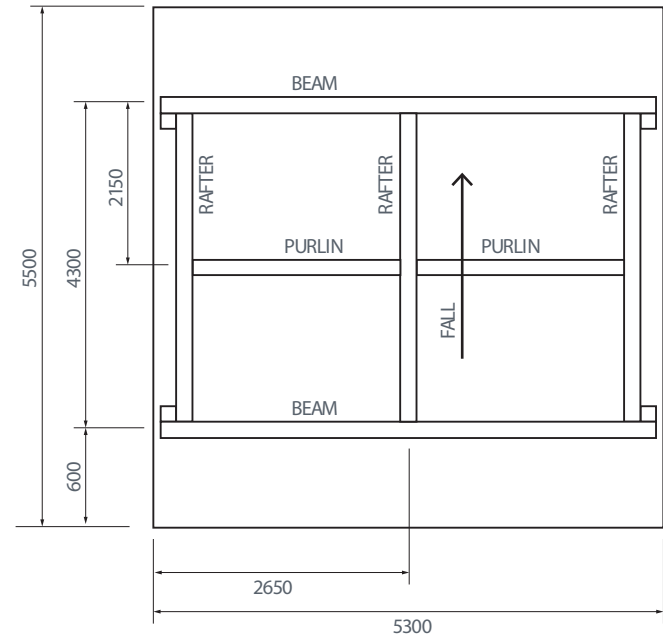

PLAN VIEW

HELPFUL TIPS

Sweep the roof and clean gutters after the completion of work. Ensure any swarf and rivet stubs are removed as they can cause unsightly rust stains.

Leave bracing struts and construction props in position until structure is complete and concreted in. This stabilises the structure and holds it square during construction.

Double check all measurements and drilling locations before proceeding.

Regularly check framework for squareness and vertical alignment to make sure it hasn't moved during construction.

MAINTENANCE

Regular washing or hosing of the inside and outside of your Stratco Frontier Carport will ensure it looks its best at all times. Refer to the "Selection, Use and Maintenance of Stratco Steel Products" brochure for complete details of maintenance requirements.

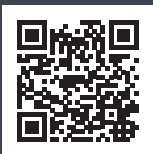

« SCAN THIS QR CODE TO FIND A STRATCO NEAR YOU

1300 155 155
stratco.com.au

All brands and logos/images accompanied by © or ™ are trade marks of Stratco (Australia) Pty Limited. © Copyright December 2025

How To.

