



# INSTALLATION GUIDE

## **OUTBACK® GABLE PATIO SUNROOF**

The New Generation Outback® Gable Patio system has been designed and engineered to generate modern and versatile structures that provide more design flexibility and increased spanning capabilities.

The New Generation Outback® Gable Patio system integrates new bracketry, new fixings, new design options and new accessories, to produce the best gable patio product on the market today.

### **BEFORE YOU START**

It is important to check your Local Government Authority requirements before the installation of your new Stratco Outback® Gable Patio System.

It is the builder's responsibility to ensure any existing structure that an Outback® Gable Patio is being attached to is adequately reinforced to accommodate the additional loads imposed by the verandah, patio or carport. Read these instructions thoroughly before starting your project and refer to them constantly during each stage of construction. Contact Stratco for advice if you do not have the necessary tools or information.

Carefully read these instructions, along with the 'Outback Gable Installation Guide'. Lay out the main components in order of assembly on the ground and check them against the delivery note. The 'Components' section identifies each part of your Stratco Outback Gable Sunroof Bank and shows the location of the components.

If you do not have all the necessary tools or information, contact Stratco for advice. Before starting lay out all components and check them against the delivery docket. The parts description identifies additional gable parts, and the component layout diagram indicates their fastening position.

### **TOOLS AND HARDWARE REQUIRED**

- Tape Measure
- Marker or Pen
- Spirit Level
- String Line
- Plumb Line
- Hack Saw
- Tin Snips
- Angle Grinder
- Post-Hole Digger
- Drill
- 5/16" Hex-Head Driver
- 3/8" Hex-Head Driver
- T30 Torx Driver
- ø3.2mm Drill Bit
- ø5.0mm Drill Bit
- ø12mm Drill Bit
- ø16mm Drill Bit
- ø12mm Masonry Drill Bit
- Rivet Gun
- Silicone Gun
- Clamps
- Spanners or Hex-Head Socket Set
- Adjustable Construction Props
- Ladders

# **OUTBACK® GABLE SUNROOF**

## CONTENTS

### 1 - FRAMEWORK PREPARATION

Rear Attached .....	3
Side Attached.....	3
Rafter Preparation.....	3

### 2 - GUTTER INSTALLATION

Bottom Gutter Preparation.....	4
Top Gutter Preparation.....	4
Side Gutter Preparation (Lower End).....	4
Side Gutter Preparation (Upper End).....	5
Gutter Positioning Sequence .....	5

### 3 - LOUVRE EXTRUSION INSTALLATION

Louvre Extrusion Identification.....	6
Louvre Extrusion Preparation (Sunroof Banks up to 3 Metres) ...	6
Louvre Extrusion Preparation (Sunroof Banks over 3 Metres) ....	7
Louvre Extrusion Connection.....	7
Side Beam Preparation (Small Beam Cap) .....	8
Side Beam Preparation (Large Beam Cap) .....	8
Top Louvre Extrusion (Louvre Bank on both sides of Ridge Beam) ...	9
Top Louvre Extrusion (Louvre Bank on one side of Ridge Beam) .....	9
Downpipe Outlet Installation.....	10
Sunroof Gutter Fixing.....	10

### 4 - LOUVRE INSTALLATION

End Cap Bush Installation.....	11
Spring and Spacer Ends.....	11
Install Louvres.....	11

### 5 - ACTUATOR INSTALLATION

Electronic Control Box .....	11
Using the Remote Control.....	12
Assembling Actuator Components .....	12
Installing Actuator.....	13
Running Actuator Cables.....	13
Link Rod Preparation.....	14
Link Pin Installation.....	14
Connecting Drive Arm to Link Rod.....	14

Adjusting the Closed Louvre Position .....	15
Louvres Are Not Fully Closed.....	15
Louvres Are Closed Too Tightly.....	15

### 6 - RAFTER FLASHING INSTALLATION

Side Capping Preparation (Cooldek CGI & Classic).....	16
Side Capping Preparation (CGI).....	17
Rafter Flashing Preparation (Outback Deck) .....	18
End Rafter Flashing Installation .....	19
Double Rafter Flashing Installation.....	19

### 7 - BEAM CAP FLASHING INSTALLATION

Beam Cap Flashing Installation.....	20
Beam Cap Flashing Installation (Adjacent Outback Deck) ...	20
Beam Cap Flashing Installation (Adjacent Cooldek CGI & Cooldek Classic).....	20

### 8 - RIDGE CAPPING INSTALLATION

Ridge Capping Installation (Louvre Bank on both sides of Ridge Beam) .....	21
Ridge Capping Installation (Louvre Bank on one side of Ridge Beam) .....	21

### 9 - LOUVRE FLASHING INSTALLATION

Link Rod Flashing Installation.....	22
Closing Up/Closing Down Flashing Installation .....	22

### 10 - RIDGE SHROUD FLASHING INSTALLATION (OPTIONAL)

.....	22
-------	----

### 11 - BARGE TRIM INSTALLATION

.....	23
-------	----

### 12 - DOWNPIPE INSTALLATION

Rain Sensor.....	23
------------------	----

### 13 - FINAL FIXING

.....	23
-------	----

### 14 - TROUBLESHOOTING

.....	24
-------	----

### 15 - MAINTENANCE

.....	26
-------	----

## FRAMEWORK PREPARATION

Outback Gable Sunroof Bank installation can only commence once the main Outback Gable framework has been completed. This includes perimeter framing, rafters and ridge beams. Framework should be fixed and braced in position prior to installation of an Outback Gable Sunroof Bank.

This section should be referred to for specific detail relating to Outback Gable Sunroof while completing the *Attaching to Existing Structure* section of the broader Outback Gable Patio.

### REAR ATTACHED

Rear attached Outback Gable Patios will not interfere with the Sunroof Bank Box Gutters. The attachment beam is installed as normal.

### SIDE ATTACHED (BEAM CAP LARGE)

Where the Outback Gable Patio is attached along the Side Beam that includes a Sunroof Bank, consideration must be given to the position of the attachment fixings.

Side attachment beams fitted with a Large Beam Cap will be fixed through the Outback Beam below the Bottom Gutter. The optimal location for attachment beam through holes is 75mm from the bottom of the Outback Beam (Figure 1.0)

Refer to Figure 1.0 with the Outback Gable Installation Manual to complete this step.

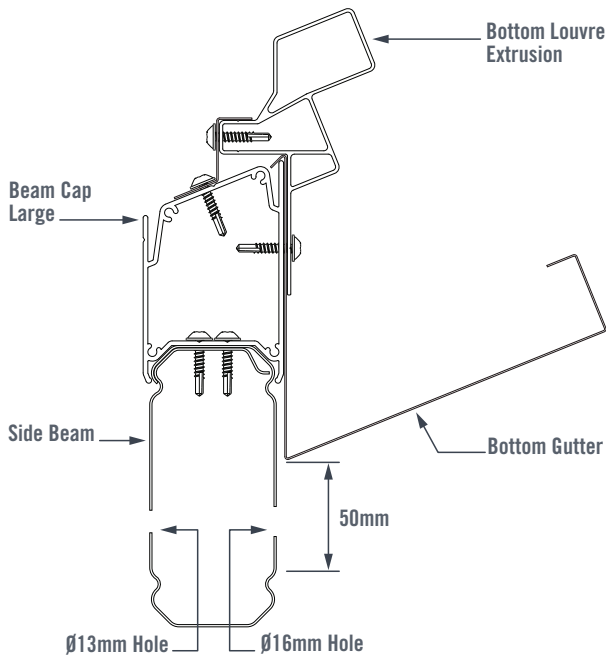

FIGURE 1.0

### SIDE ATTACHED (BEAM CAP SMALL)

Where the Outback Gable Patio is attached along the Side Beam that includes a Sunroof Bank, consideration must be given to the position of the attachment fixings.

Side attachment beams fitted with a Small Beam Cap will be fixed through the Outback Beam and Bottom Gutter. The optimal location for attachment beam through holes is 90mm from the bottom of the Outback Beam (Figure 1.1)

Refer to Figure 1.1 with the Outback Gable Installation Manual to complete this step.

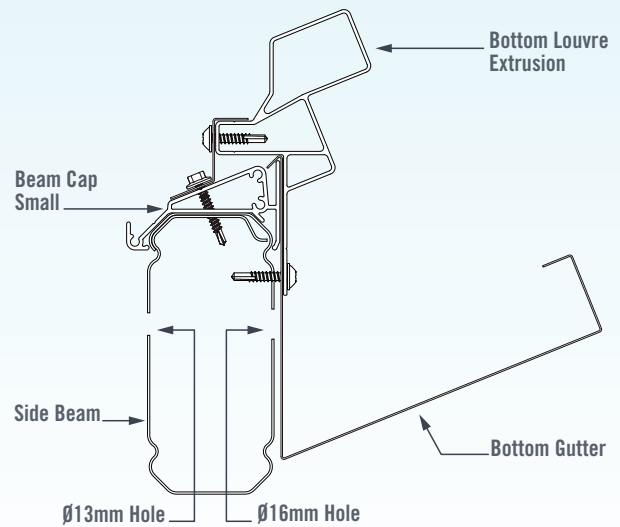

FIGURE 1.1

## RAFTER PREPARATION

Once the Outback Gable Ridge Beams have been installed, prepare for the Gable Sunroof Box Gutter installation by temporarily removing fixings from the inside faces of the Rafters and Rafter-to-Beam Brackets (Figure 1.2).

Make note of the removed screw locations as screws will need to be reinstalled into the same locations at the completion of the build.

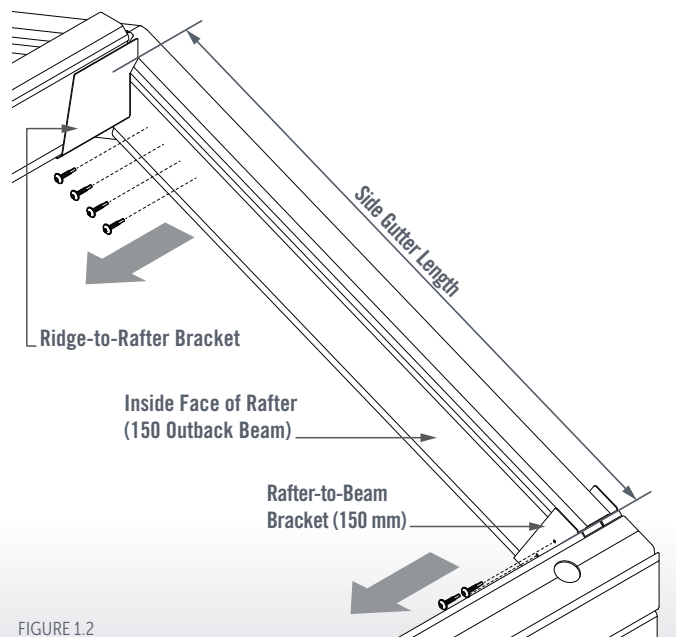

FIGURE 1.2

## GUTTER INSTALLATION

Notes: Maintain protective covering on gutters until it is necessary to remove.

Layout gutters in relative position to each other prior to marking.

Gutters will share fixings with Louvre Extrusions, Rafter Knuckles, Rafter to Beam Brackets.

### BOTTOM GUTTER PREPARATION

Measure the distance between the inside faces of the Rafter-to-Beam Brackets. This measurement, less 5mm, will be the length of the bottom gutter.

Measure the width of the Side Gutter (Lower End) (Figure 2.0). Using the Side Gutter width, mark out gutter mitre trim lines at the end of the Bottom Gutter (Figure 2.0).

Using tin snips, cut the marked out Bottom Gutter mitre retaining a 20mm tag at the front edge.

Fold tag to 90° (Figure 2.0).

Repeat these steps at the other end of the Bottom Gutter.

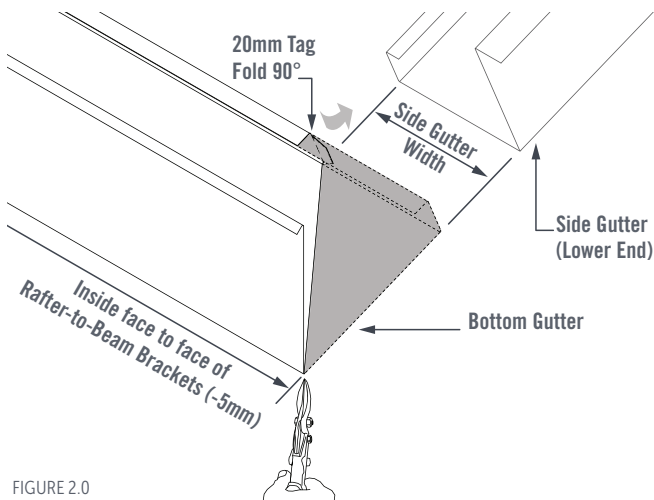

FIGURE 2.0

### TOP GUTTER PREPARATION

Measure the distance between the inside faces of the Rafters at the Ridge. This measurement, less 5mm, will be the length of the top gutter.

Measure the width of the Side Gutter (Upper End) (Figure 2.1). Using the Side Gutter width, mark out gutter mitre trim lines at the end of the Top Gutter. Allow 30mm of additional Top Gutter length for a 30mm Tag (Figure 2.1).

Using tin snips, cut the marked out Top Gutter retaining a 20mm tag at the front edge and a 30mm tag on the vertical face (Figure 2.1).

Fold both tags to 90° (Figure 2.1).

Repeat these steps at the other end of the Top Gutter.

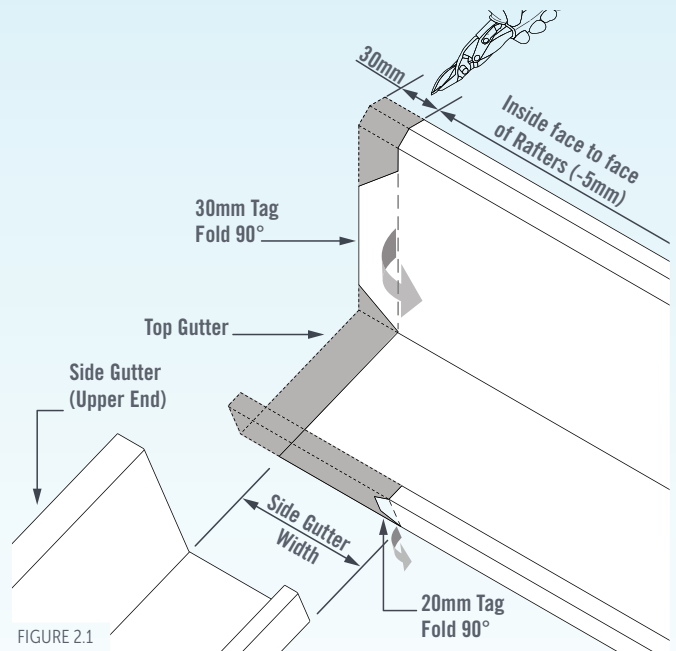

FIGURE 2.1

### SIDE GUTTER PREPARATION (LOWER END)

Measure the distance between the outside face of the Ridge-to-Rafter Bracket to the front face of the Beam Capping (Figure 2.2).

Measure the width of the Bottom Gutter (Figure 2.2). Using the Bottom Gutter width, mark out gutter mitre trim lines at the end of the Side Gutter (Lower End) (Figure 2.2).

Using tin snips, cut the marked out Side Gutter (Lower End) retaining a 30mm tag on the vertical face.

Fold tag to 90°. (Figure 2.2).

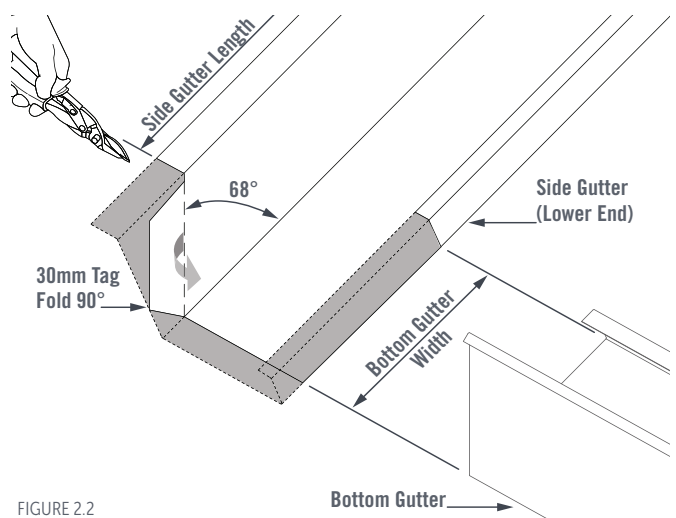

FIGURE 2.2

Select the lower corner which will become the location for the Downpipe Outlet. This corner will require additional trimming. Measure, mark and using Tin Snips, trim the Side Gutter at the Lower End (Figure 2.3).

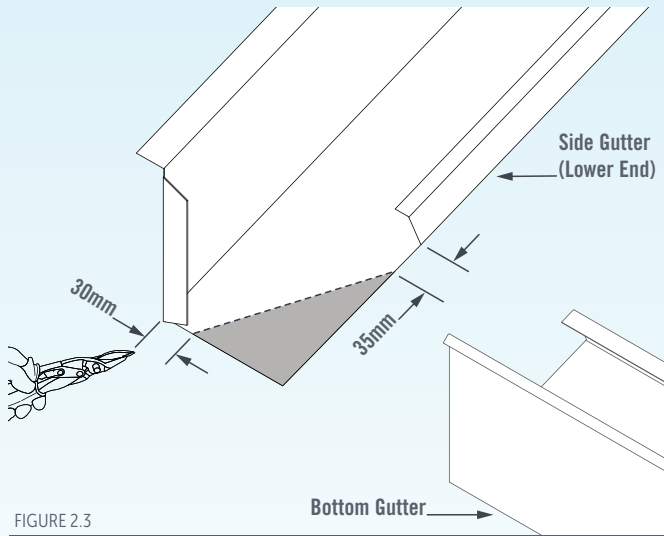

FIGURE 2.3

**SIDE GUTTER PREPARATION (UPPER END)**

Measure the distance between the outside face of the Ridge-to-Rafter Bracket to the back face of the Rafter-to-Beam Bracket (Figure 2.4).

Measure the width of the Top Gutter (Figure 2.4). Mark out gutter mitre trim lines at the end of the Side Gutter (Upper End) (Figure 2.4).

Cut the marked out Side Gutter (Upper End) mitre using tin snips.

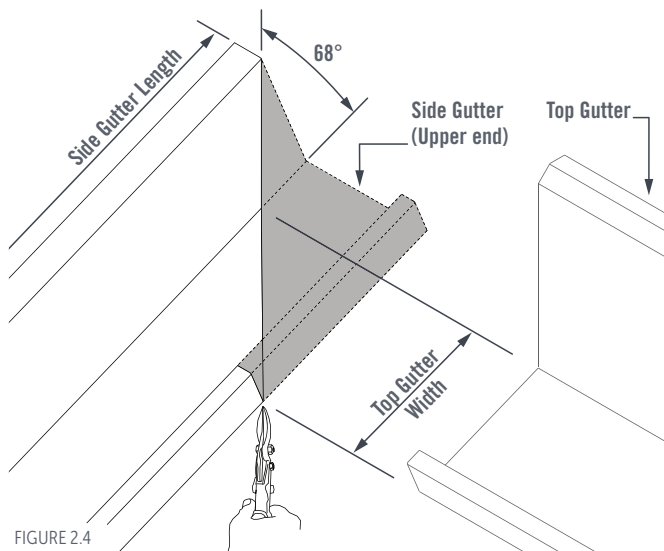

FIGURE 2.4

**GUTTER POSITIONING SEQUENCE**

Notes: All figures show Large Beam-Capping unless installation details differ between Large and Small Beam-Capping.

All four gutters should be positioned to ensure mitre connections are tightly fitted. Fixing of gutters will be completed at a later step.

Remove any protective covering from the Bottom Gutter. Position the Bottom Gutter by hanging it on the Beam Capping (Figure 2.5).

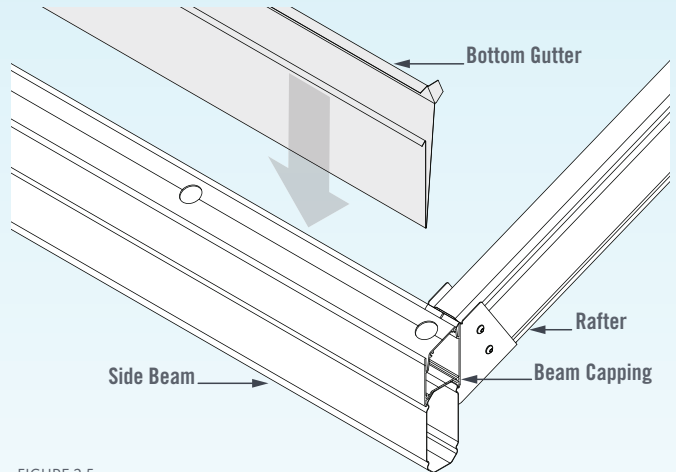

FIGURE 2.5

Remove any protective covering from the Side Gutters. Position Side Gutters on each rafter, overlapping the lower end into the Bottom Gutter mitre (Figure 2.6).

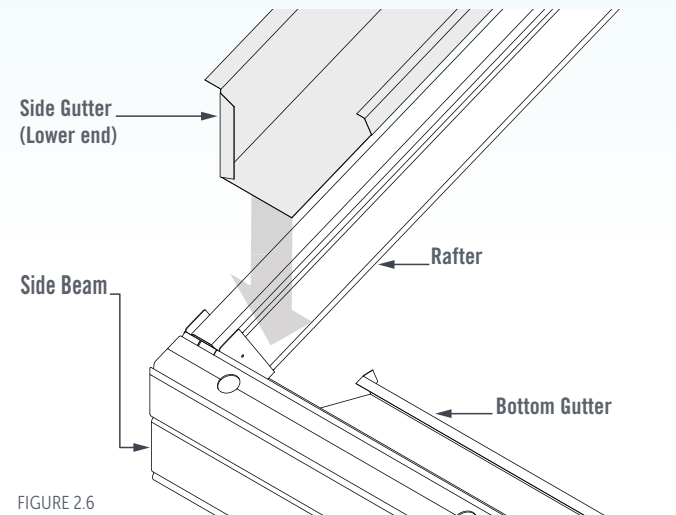

FIGURE 2.6

Remove any protective covering from the Top Gutter. Position the Top Gutter onto the Ridge Beam, overlapping into the Side Gutter mitre (Figure 2.7).

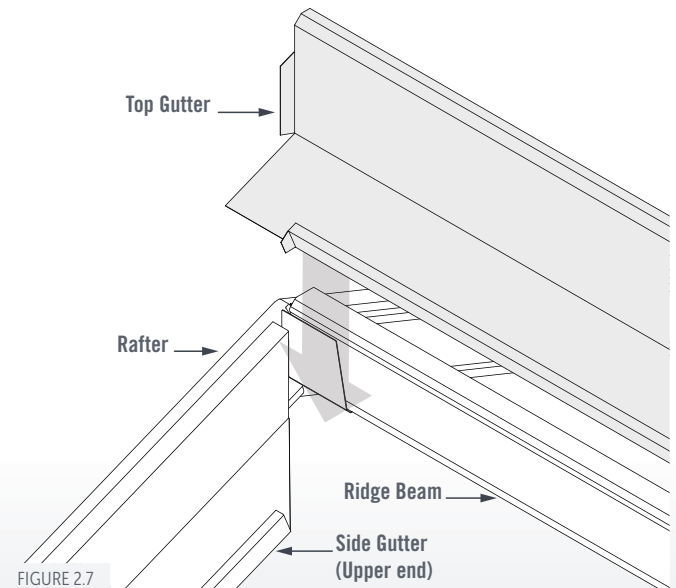

FIGURE 2.7

## LOUVRE EXTRUSION INSTALLATION

### LOUVRE EXTRUSION IDENTIFICATION

The Top and Bottom Louvre Extrusions come at a standard 3 metre length. They have square holes in the front face referred to as Louvre Mounting Holes (Figure 3.0 & 3.1). There are two Types of Louvre Extrusions (Type 1 and Type 2) for both Top, and Bottom.

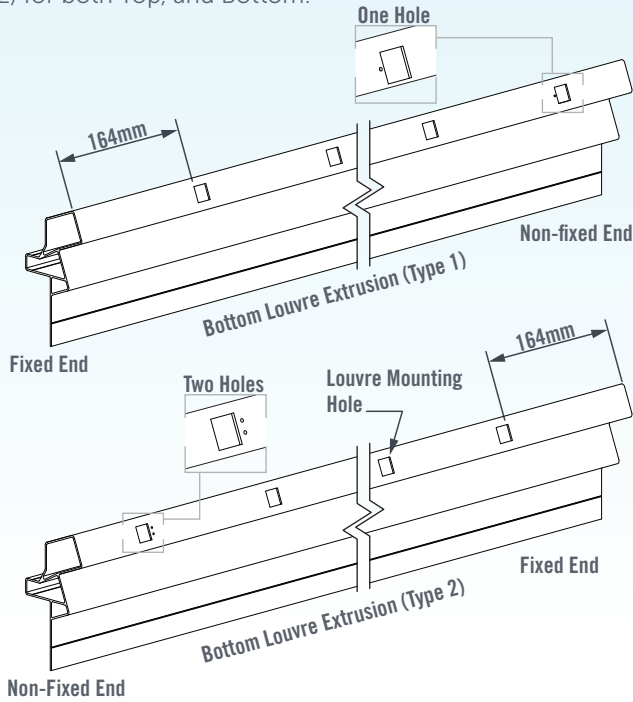

FIGURE 3.0

Type 1 is the mirror image of Type 2. Each can be identified by the small round holes at the 'non-fixed' end of the extrusion and the 164mm spacing to the edge of the closest hole at the 'fixed' end' (Figure 3.0 & 3.1).

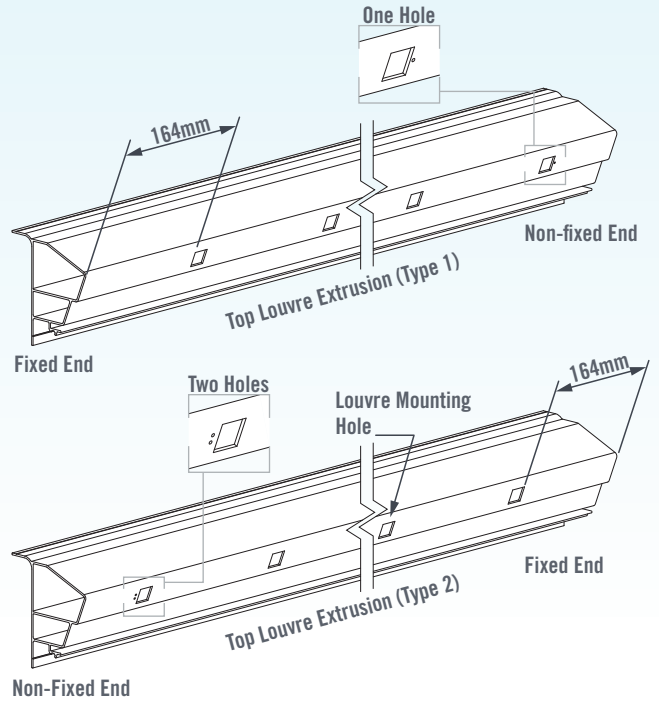

FIGURE 3.1

### LOUVRE EXTRUSION PREPARATION (SUNROOF BANKS UP TO 3 METRES)

Before mounting the Louvre Extrusions, the Louvre closing direction and datum end must be known. A Type 1 Extrusion must always face a Type 2 Extrusion. This will ensure alignment of the Louvre Mounting Holes (Figure 3.2).

For units up to three metres, cut the Louvre Extrusions back from the 'non-fixed' end (end of the extrusions which have the small round holes) (Figure 3.0 & 3.1).

Measure the distance between the inside faces of the Side Gutters at the Ridge and Valley of the unit. This distance minus a relief of 5mm will be the length of the Louvre Extrusions. Cut the Louvre Extrusions to the correct length.

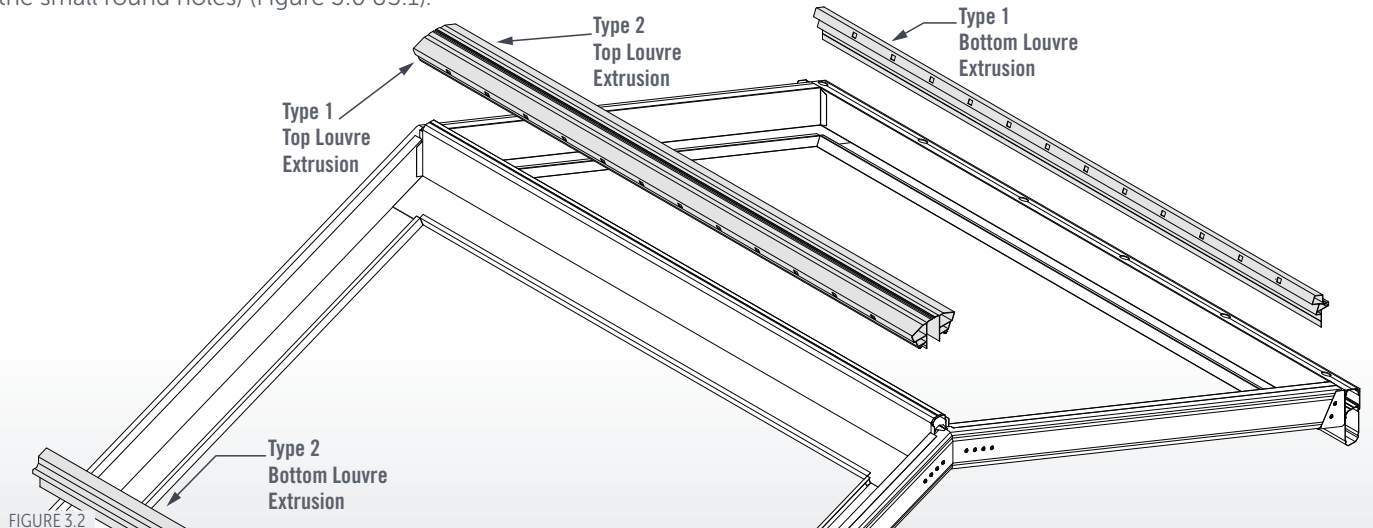

FIGURE 3.2

**LOUVRE EXTRUSION PREPARATION  
(SUNROOF BANKS OVER 3 METRES)**

If the Sunroof Bank is longer than three metres in length, additional Louvre Extrusions will be required. Where a Type 1 Louvre Extrusion is used at the fixed end, a Type 2 Louvre Extrusion will be placed alongside to create the additional length (Figure 3.3). Where a Type 2 Louvre extrusion is used at the fixed end, a Type 1 will be placed alongside.

When placing Louvre Extrusions alongside one another, the 'non-fixed' ends of the extrusions with the small round holes

must butt together. When butted together correctly, the Louvre Extrusions will have a spacing of 178mm between the square holes (Figure 3.3 & 3.4).

Measure the distance between the inside faces of the Side Gutters at the Ridge and Valley of the unit. This distance minus a relief of 5mm will be the length of the Louvre Extrusions. Cut the Louvre Extrusions to the correct length.

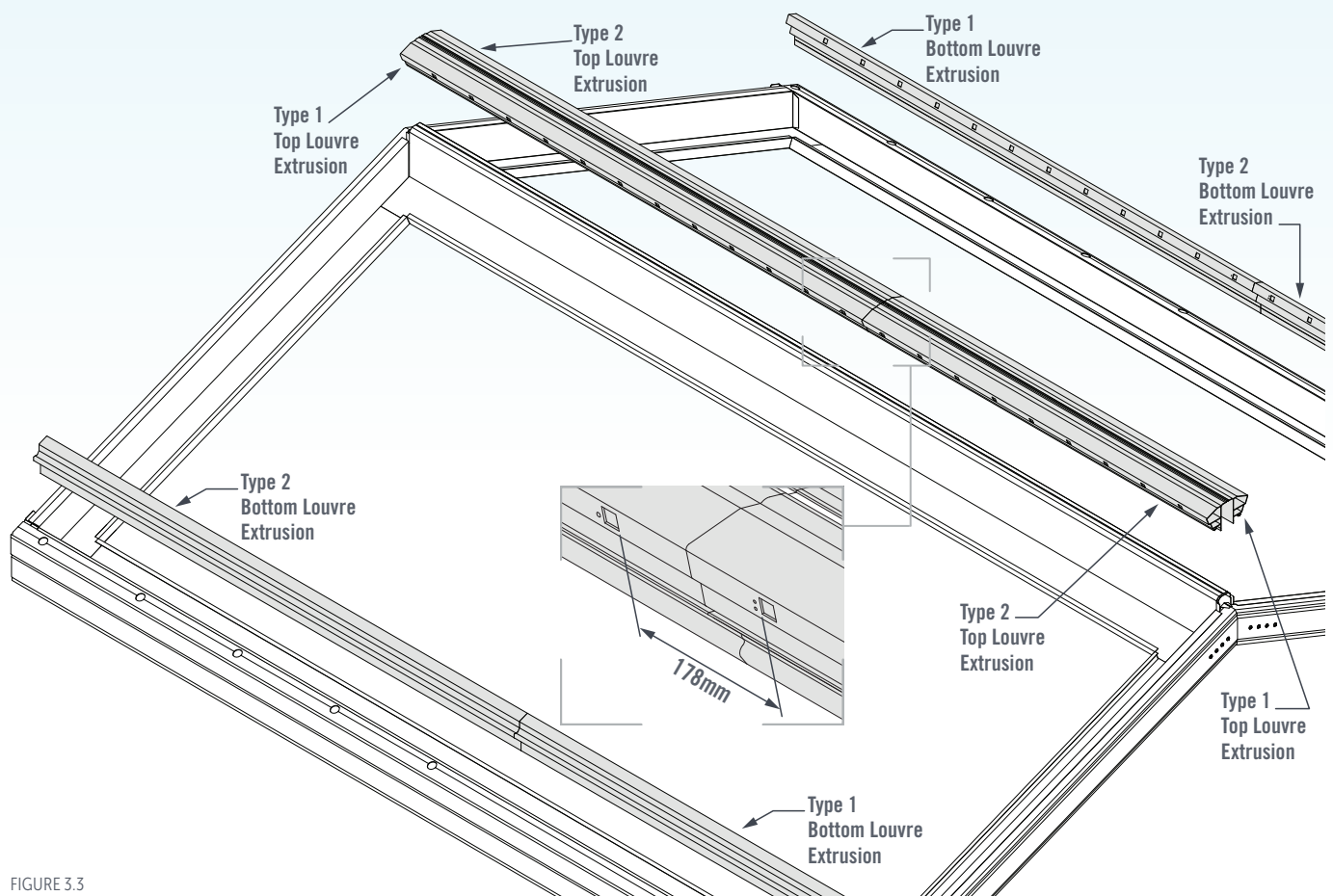

FIGURE 3.3

**LOUVRE EXTRUSION CONNECTION**

Note: This step is only required for Sunroof Banks over 3 metres.

A spacing template has been included to make sure the distance between connecting Louvre Extrusions is precise. During Installation, clamp the second extrusion in-place and use a rubber mallet to hammer two plastic end cap bushes into the template to hold it across the join (Figure 3.4).

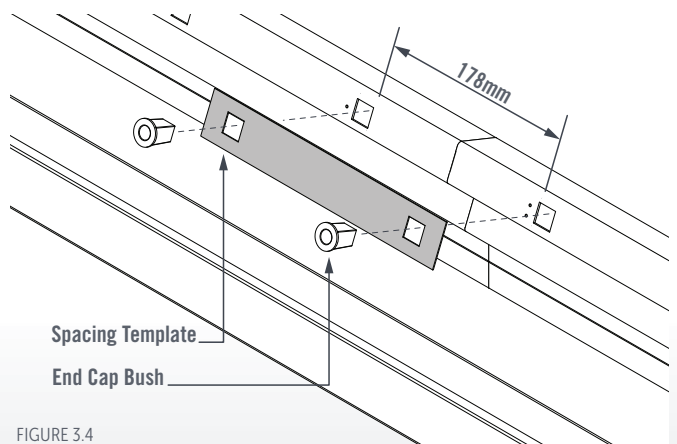

FIGURE 3.4

## SIDE BEAM PREPARATION (SMALL BEAM CAP)

Once all gutters are in place, position the Bottom Louvre Extrusion(s) and Mounting Support Flashing(s) (Figure 3.5).

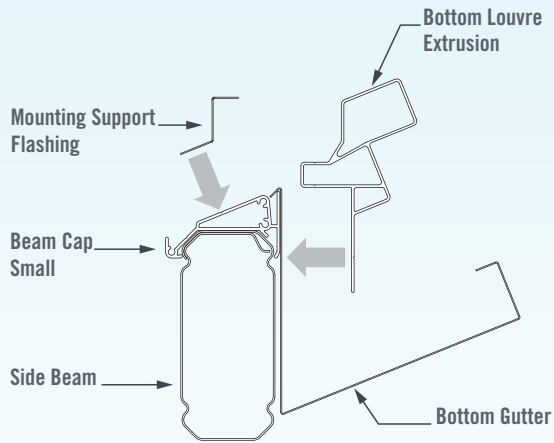

FIGURE 3.5

Secure the Bottom Louvre Extrusion(s) to the Outback Beam through the internal face with Outback Self-Drilling Screws at 900mm centres (Figure 3.6).

Fix the Mounting Support Flashing to the Small Beam Cap with 12gx35 Hex Head Self-Drilling Screws at 900mm centres (Figure 3.6). Fix the Mounting Support Flashing to the Bottom Louvre Extrusion with Outback Self-Drilling Screws at 900mm centres (Figure 3.6).

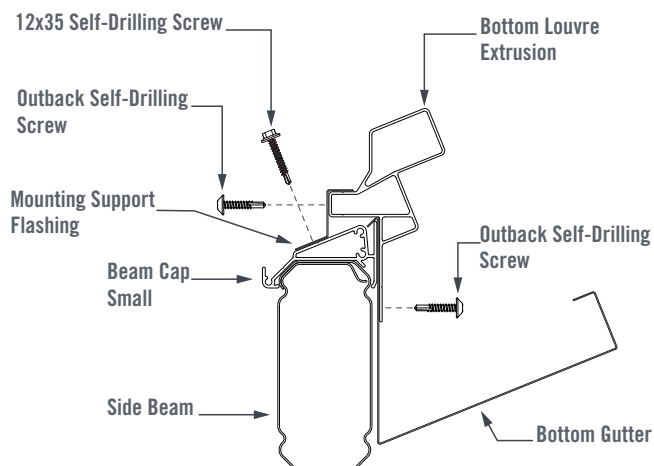

FIGURE 3.6

## SIDE BEAM PREPARATION (LARGE BEAM CAP)

Once all gutters are in place, position the Bottom Louvre Extrusion(s) and Mounting Support Flashing(s) (Figure 3.7).

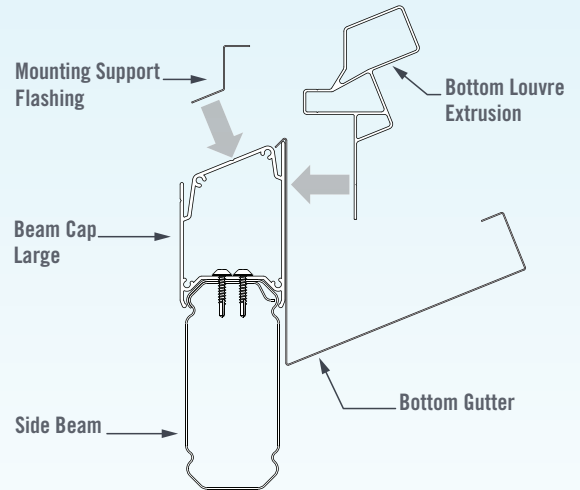

FIGURE 3.7

Secure the Bottom Louvre Extrusion(s) to the Outback Beam through the internal face with Outback Self-Drilling Screws at 900mm centres (Figure 3.8).

Fix the Mounting Support Flashing to the Large Beam Cap with Outback Self-Drilling Screws at 900mm centres (Figure 3.8). Fix the Mounting Support Flashing to the Bottom Louvre Extrusion with Outback Self-Drilling Screws at 900mm centres (Figure 3.8).

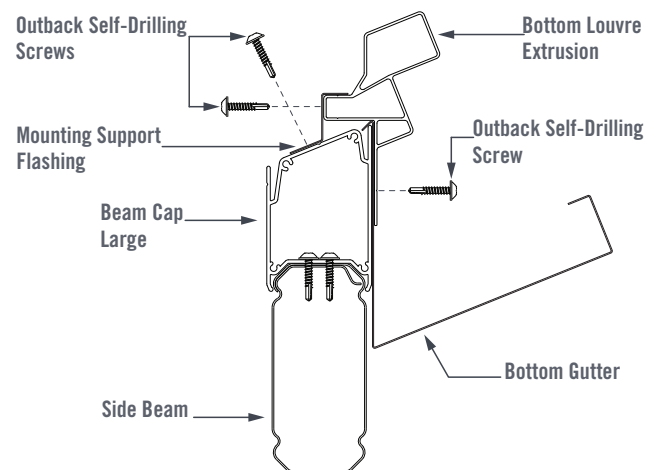

FIGURE 3.8

**TOP LOUVRE EXTRUSION  
(LOUVRE BANK ON BOTH SIDES OF RIDGE BEAM)**

Position the Aluminium Flat Bar atop the Ridge Beam, on top of the Top Gutters. Position the Top Louvre Extrusions on top of the Aluminium Flat Bar (Figure 3.9).

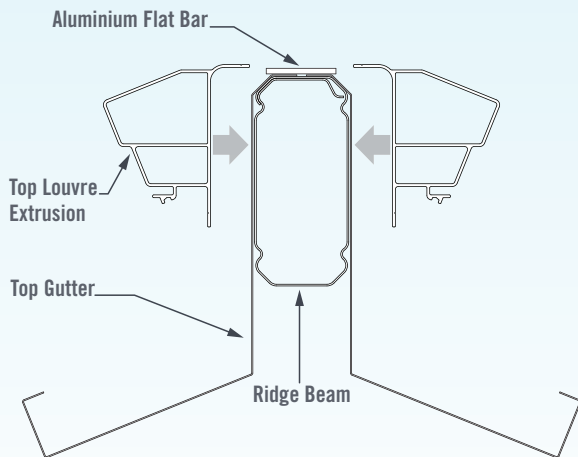

FIGURE 3.9

Secure the Top Louvre Extrusions using Outback Self-Drilling Screws at 900mm centres through both the top and front faces (Figure 3.10).

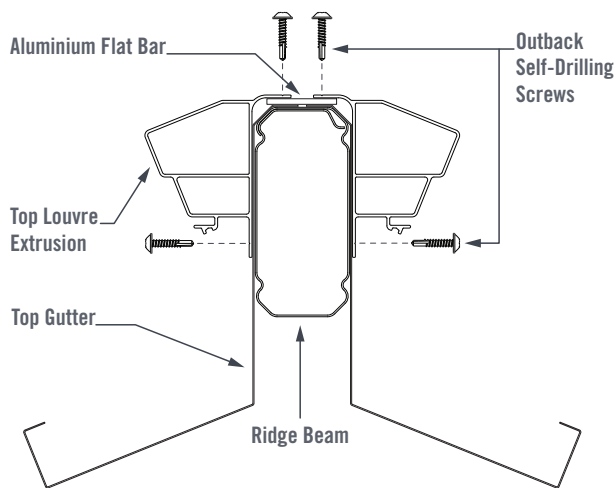

FIGURE 3.10

**TOP LOUVRE EXTRUSION  
(LOUVRE BANK ON ONE SIDE OF RIDGE BEAM)**

Note: This step is only required for patios with a louvre bank on one side of the Ridge Beam and solid roof decking on the other side.

Cut along length of the Ridge Extrusion at the location shown in (Figure 3.11).

Position the Ridge Extrusion(s) atop the Ridge Beam, on top of the Top Gutter and secure using Outback Self-Drilling Screws at 900mm centres through the side face (Figure 3.12 & 3.13).

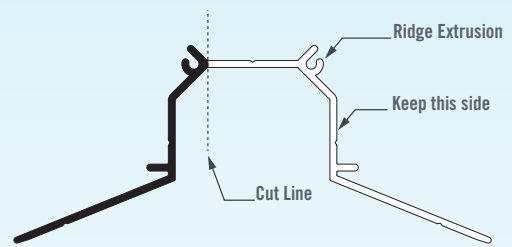

FIGURE 3.11

Position the Ridge Extrusion Top Flashing on top of the Ridge Extrusion and secure using Outback Self-Drilling Screws at 900mm centres through the top face (Figure 3.12 & 3.13).

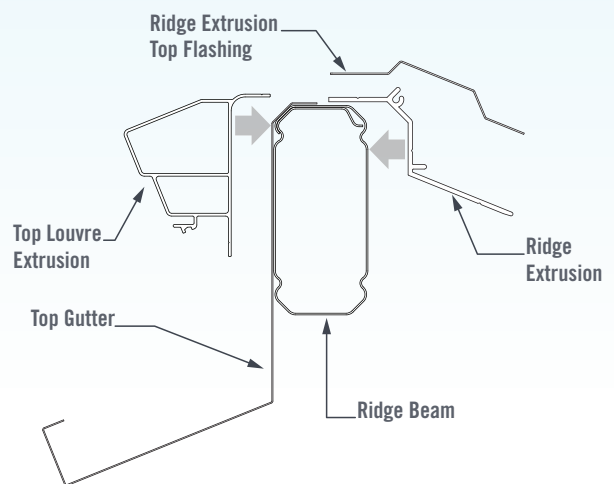

FIGURE 3.12

Position the Top Louvre Extrusion on top of the Ridge Extrusion Top Flashing and secure using Outback Self-Drilling Screws at 900mm centres through both side and top faces (Figure 3.12 & 3.13).

Note: The Ridge Extrusion Top Flashing profile shown is for use with Outback Deck. The profile will differ slightly for use with CGI, or Cooldek. The Installation sequence will remain the same.

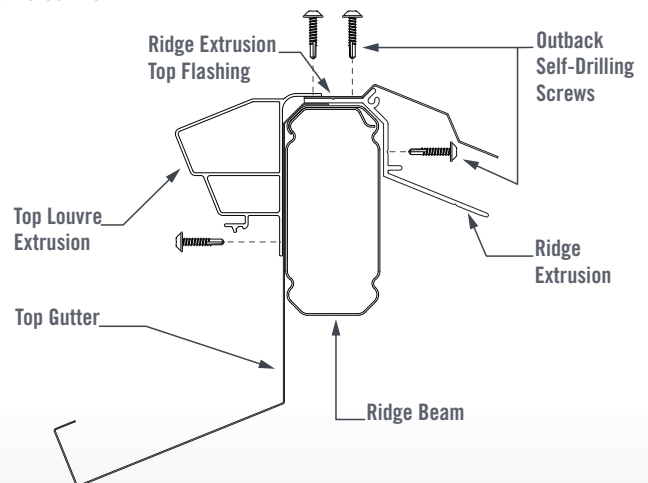

FIGURE 3.13

## DOWNPIPE OUTLET INSTALLATION

Cut an opening in the lower corner of the gutter to fit the size of your specific downpipe outlet. Position the outlet through the hole (Figure 3.14 & 3.15).

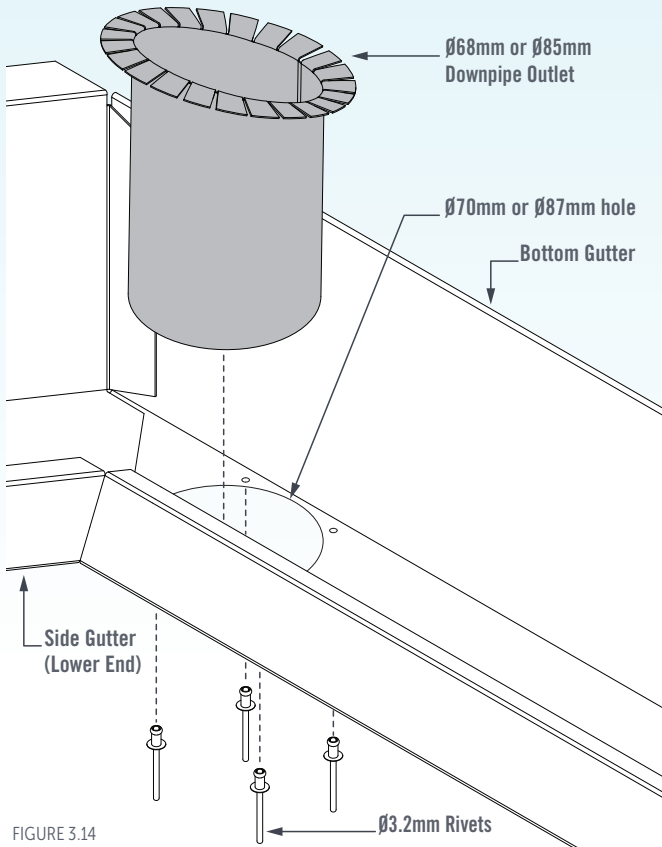

FIGURE 3.14

Drill four ø3.5mm holes and fasten in-place using four rivets (Figure 3.14 & 3.15). Silicone all material connections and joins.

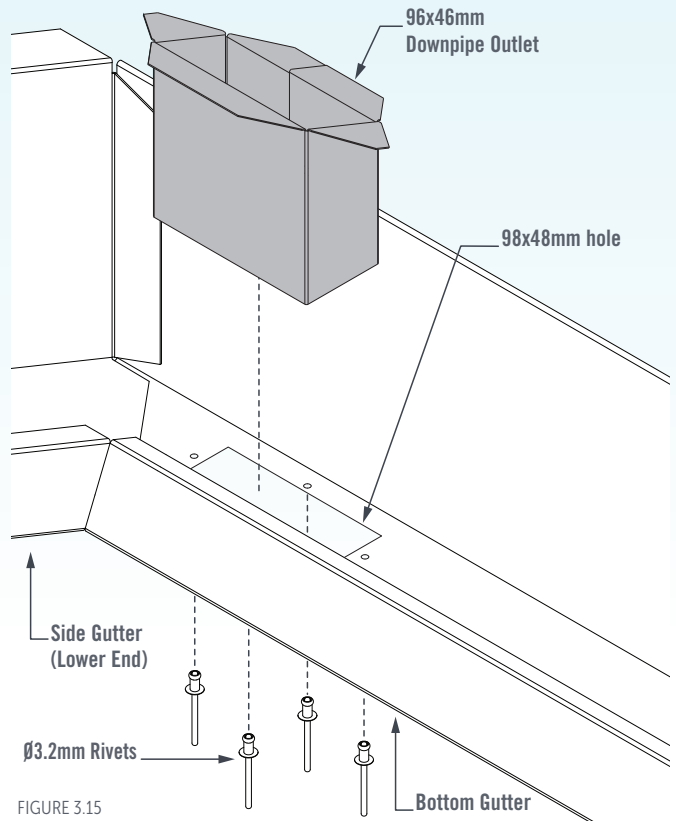

FIGURE 3.15

## SUNROOF GUTTER FIXING

Clean gutters to ensure they are free of any swarf.

Drill one ø4.9mm hole through each internal corner tag and fasten in-place using a ø4.8mm rivet.

Drill four ø4.9mm holes through the underside of the gutter along the diagonal mitre seam and fasten in-place using ø4.8mm rivets (Figure 3.16). Silicone all material connections and joins.

Use silicone to seal gaps, tags, rivets and mitre overlaps.

Repeat at each of the four corners.

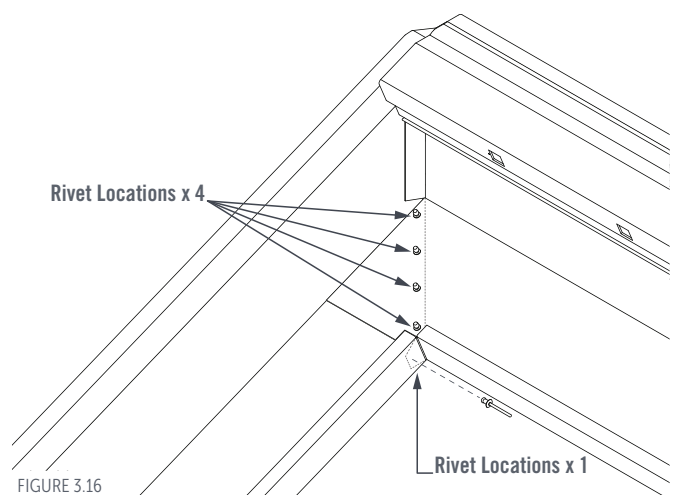

FIGURE 3.16

## LOUVRE INSTALLATION

### END CAP BUSH INSTALLATION

Insert End Cap Bushes into each of the square Louvre Extrusion Mounting Holes (Figure 4.0). Using a rubber mallet, tap the bushes into position.

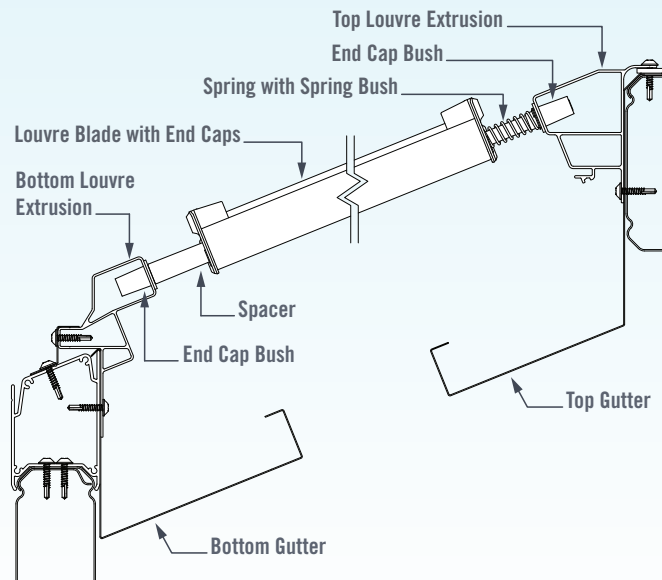

FIGURE 4.0

### SPRING AND SPACER ENDS

Establish the correct closing up and closing down orientation of the Sunroof Bank. Springs will always be at the Ridge Endcap. Spacers will always be at the lower Endcap.

Slide a spring bush into the end of each spring and thread over the Endcap Pin. (Figure 4.1).

At the opposite end of the Louvre, slide a plastic Spacer over the Endcap pin. The mark on the Spacer must be at the inside end of the pin (Figure 4.1).

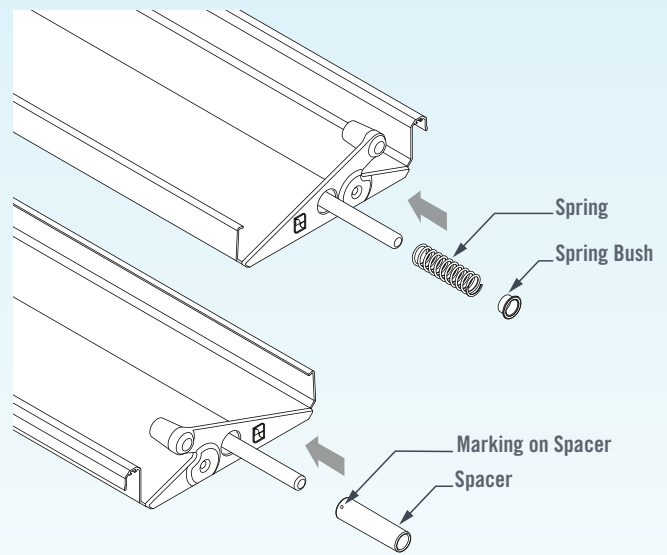

FIGURE 4.1

### INSTALL LOUVRES

Insert the top end (spring end) into the first Top Louvre Extrusion Mounting Hole and compress the spring completely. (Figure 4.0).

Lower the spacer end and insert it into the aligning Bottom Louvre Extrusion Mounting Hole.

Determine the approximate location for the Actuator, and leave two Louvres out to allow for easy installation of the Actuator Cover.

Note: The Actuator can be located anywhere along the Bottom Louvre Extrusion, however, it must be at least two louvres in from the ends and three Louvres either side of a join in the Bottom Louvre Extrusions.

## ACTUATOR INSTALLATION

### ELECTRONIC CONTROL BOX

The control box must be installed in a position that is protected from direct weather and sharp objects. The control box must not be installed within two metres of a large air-conditioning unit or large sources of electrical noise. A suitable location may be to mount the box against an exterior wall directly under the eaves.

A standard single mains power point is required to be located directly next to the control box (within 1800mm).

Lay the main cable on the ground from the control box position to the motor position to ensure there is enough overall cable length. The kit has been supplied with a 6m connection cable for both the actuator and rain sensor. If

additional cable is required, an extension cable can be purchased and used for up to 18m in length.

Fix the control box through the four pilot holes on the cover box (Figure 5.0). If fixing to an adjacent structure use fasteners suited to the material being fixed to.

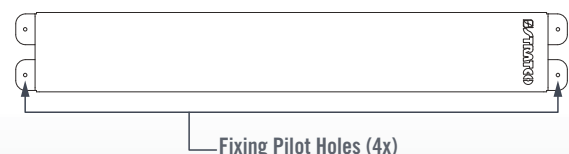

FIGURE 5.0

## USING THE REMOTE CONTROL

The remote control provided is used to control all Sunroof banks within the unit.

In units with multiple banks the two round buttons on the remote control are used to select the appropriate bank channel. Channel one (1) is always used to control all banks simultaneously. All other channels can be selected to operate banks individually.

Pressing the OPEN or CLOSE button will cause the roof to start moving in the desired direction. The roof will continue until fully open or fully closed, or until the STOP button is pressed. The stop button will stop the roof at any point.

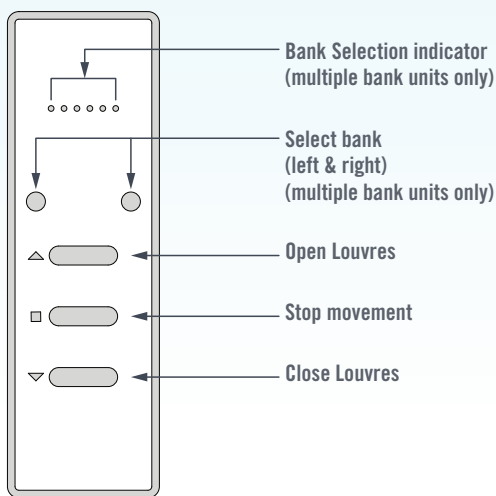

FIGURE 5.1

## ASSEMBLING ACTUATOR COMPONENTS

Pre-assemble the Actuator components at ground level. Attach the Drive Arm to the Actuator with an M8x10x20 shoulder bolt and secure with an M8 washer and lock-nut (Figure 5.2 or 5.3). The Drive Arm should be orientated so the square edge (with 90° angle) is facing the Actuator.

Note: Sunroof systems will always operate with the Actuator pulling the Louvres open. The location of the Actuator in relation to the opening direction of the Louvres will dictate whether a LH or RH Actuator kit is provided.

The appropriate orientation has been determined by Stratco, based on the opening direction of the Louvres relative to the intended Actuator location.

Attach the Adjustment Bolt to the other end of the Actuator with an M8x10x20 shoulder bolt (Figure 5.2 or 5.3). Secure with an M8 washer and lock-nut (do not over tighten the lock nut). Ensure the flat surface on the adjustment bolt faces up.

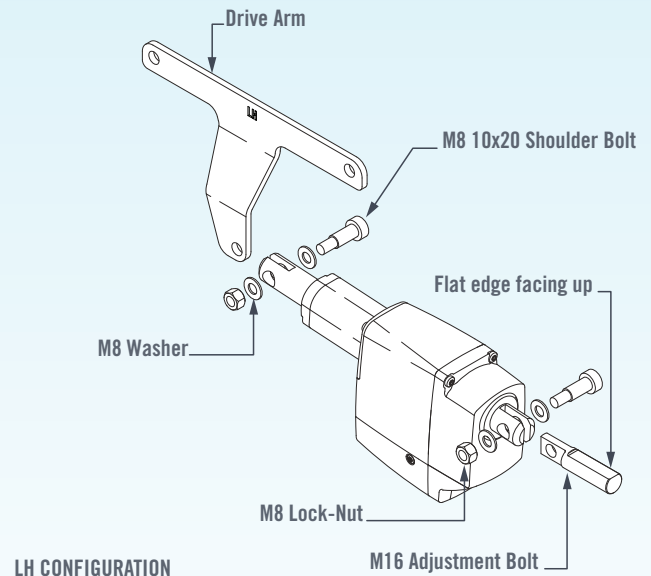

LH CONFIGURATION

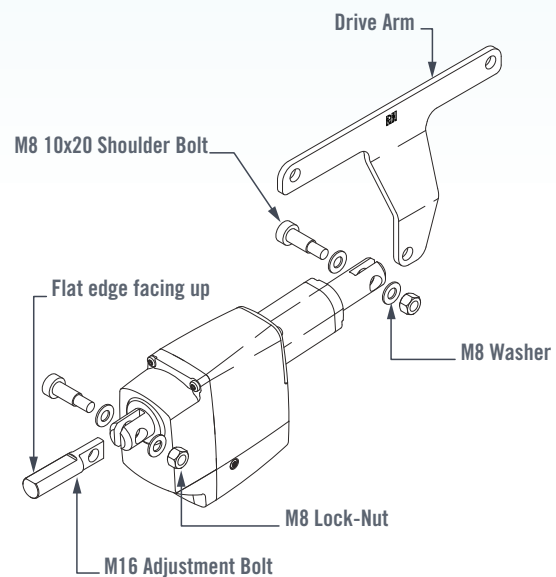

RH CONFIGURATION

FIGURE 5.2

Thread the M16 nut on to the end of the Adjustment Bolt so the nut is approximately 20mm in from the end of the Adjustment Bolt (Figure 5.2 or 5.3). Insert the Adjustment Bolt through the circular cut out located in the side of the Actuator Cover, and secure the cover with the M16 Dome Nut (Figure 5.2 or 5.3).

The Actuator and Cover are now ready to be fixed to the Bottom Louvre Extrusion within the framework.

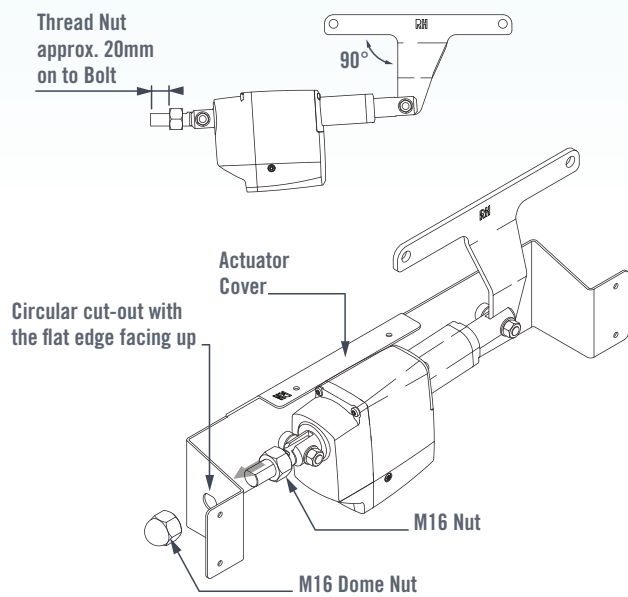
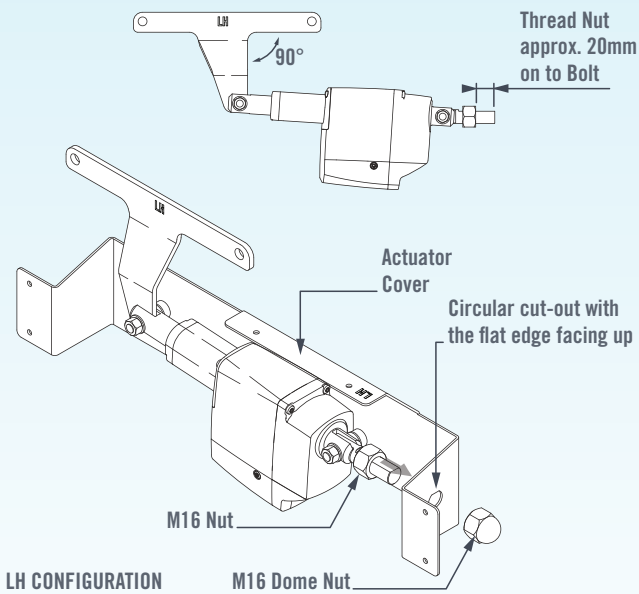
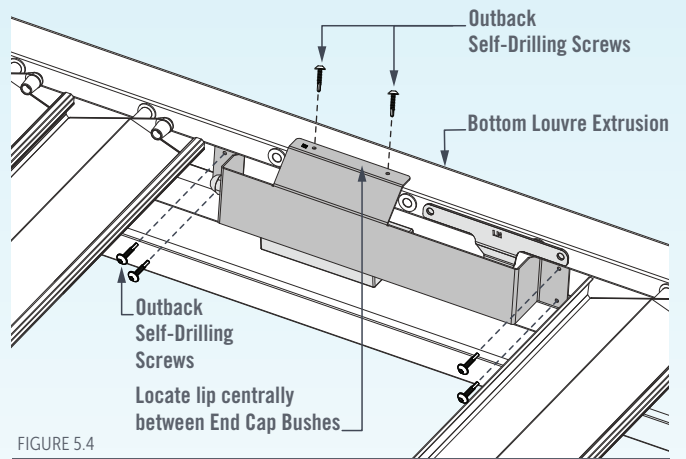

FIGURE 5.3

### INSTALLING ACTUATOR

Position the Cover so the top lip hangs over the top of the Bottom Louvre Extrusion (Figure 5.4). The lip should be located centrally between the End Cap Bushes.

Screw the top lip of the Cover to the Bottom Louvre Extrusion with two Outback Self-Drilling screws. Screw the front face of the Cover to the Bottom Louvre Extrusion with four Outback Self-Drilling screws (Figure 5.4).



### RUNNING ACTUATOR CABLES

Note: The Control Box must be unplugged from the mains power.

Run the Actuator Connection Cable from the Actuator to the Control Box location. The cable must be protected from the weather and sharp objects. The cable can be installed so that it runs through the Attachment Beam, passing through the end of the Beam and Fascia, Eaves and finally to the Control Box location.

Drill a hole next to the Actuator Cover, ensuring it is above the Gutter line (Figure 5.5). Use a 20mm drill bit with 5mm pilot hole to drill through the front face of the extrusion and beam. A Wire Pull-Through Cable may be required to pull the cable through and out the end of the beam. Allow for some cable length at the Actuator end to mitigate any water tracking towards the Actuator (Figure 5.5).

Ensure the correct end of the cable is threaded through the hole so it matches the Control Box. The Actuator Connection Cable has a 2 pin female end that connects with the 2 pin male extension leading from the Control Box.

Install the remaining two Louvres as described in 'Install Louvres' (Page 11).

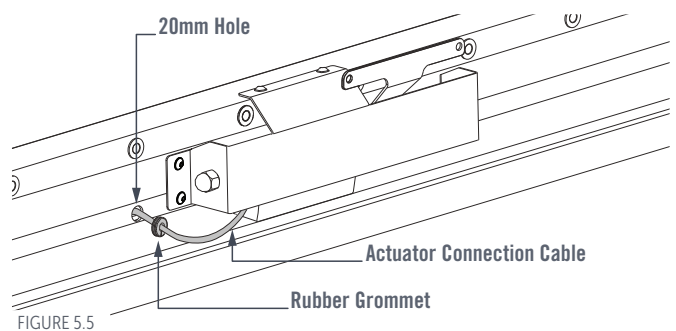

## LINK ROD PREPARATION

Lay the Link Rods on the ground, taking care not to bend them. The short angle should be facing upwards.

Determine where the Link Rod needs to be cut by counting the number of holes required for the Louvres. Mark and cut the link rod, allowing 50mm past the final hole (Figure 5.6).

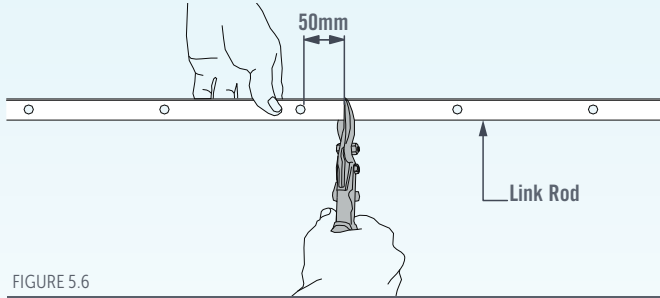

FIGURE 5.6

If the Louvre Bank is longer than 3m, additional Link Rods will be required to make up the extra length.

The additional Link Rods will need to be joined using a Link Rod Joiner. Make sure to join the Link Rods at the uncut ends.

Note: The join of the Link Rods should always be over the join of the Louvre Extrusions.

Rivet the Link Rod Joiner to the Link Rod, through the 6 pre-drilled holes on the Joiner (Figure 5.7).

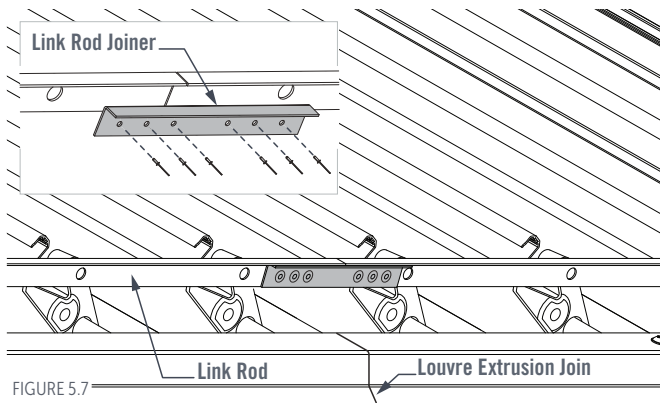

FIGURE 5.7

## LINK PIN INSTALLATION

Connect one Link Rod across each end of the Louvres. Push a Link Pin through the appropriate hole in the Link Rod, and into the End Cap (Figure 5.8).

The Link Pins should push in and snap fit into place. Repeat this process for the remaining Louvres.

Leave two holes without Pins at the Drive Arm location.

If a Link Pin needs to be removed once it has been installed, squeeze the pin's legs together with needle nose pliers and push it towards the Link Rod until it releases.

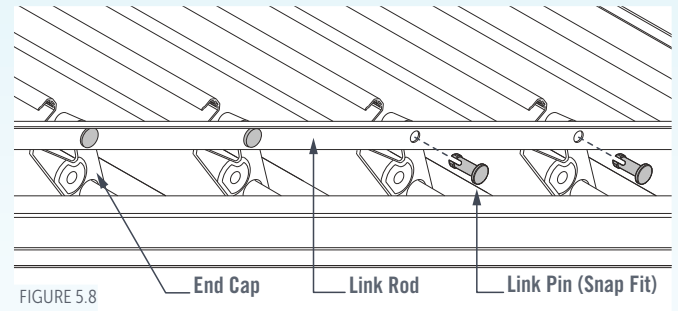

FIGURE 5.8

## CONNECTING DRIVE ARM TO LINK ROD

Line the Drive Arm up with the two remaining Link Rod holes. Rotate the first free Louvre so the End Cap hole is also aligned.

Please note that the Actuator may need to be temporarily connected to the Control Box to move the Drive Arm to a suitable position so the holes can be aligned.

Insert a Drive Arm Bush through the Drive Arm and Link Rod, and into the first Louvre End Cap. Similarly, insert another Bush into the back of the End Cap and secure with an M5 6x30 Shoulder Bolt and M5 Lock-Nut (Figure 5.9). The Shoulder Bolt head should be recessed into the back of the end Cap so that it is not visible. The M5 Lock-Nut will be located on the Drive Arm side.

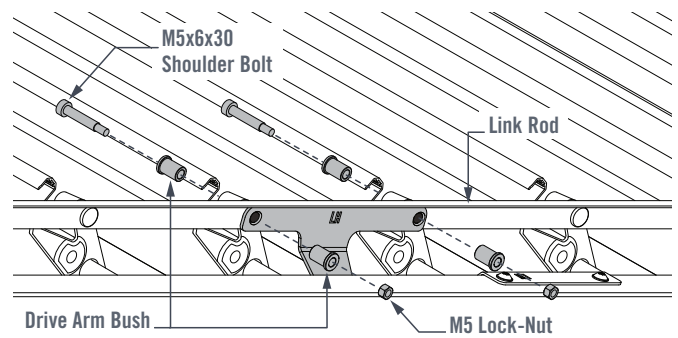

FIGURE 5.9

**ADJUSTING THE CLOSED LOUVRE POSITION**

Use the Remote Control to drive the Louvres until they are in the closed position by pressing the 'Close' button and allowing the unit to fully close.

**LOUVRES ARE NOT FULLY CLOSED**

If the Louvres have not completely closed, the position of the actuator must be adjusted.

Loosen the M16 nut by one to two rotations, and push the adjustment bolt away from the Actuator, through the circular cut-out in the side of the Actuator Cover. Tighten the Dome Nut and use the Remote Control to open and close the Louvres again (Figure 5.10).

Repeat this step until the Louvres are completely closed, without deflecting the Link Rod.

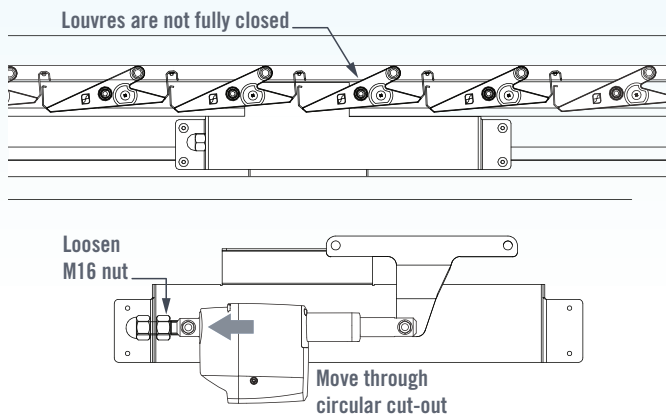

FIGURE 5.10

**LOUVRES ARE CLOSED TOO TIGHTLY**

If the Louvres have over closed, the Link Rod can be seen to significantly deflect.

To adjust the position of the Actuator, loosen the M16 Dome Nut by one to two rotations, and push the Adjustment Bolt towards the Actuator, through the circular cut-out in the side of the Cover. Tighten the M16 Nut and use the Remote Control to open and close the Louvres again (Figure 5.11).

Repeat this step until the Louvres are fully closed, ensuring the Link Rod does not deflect.

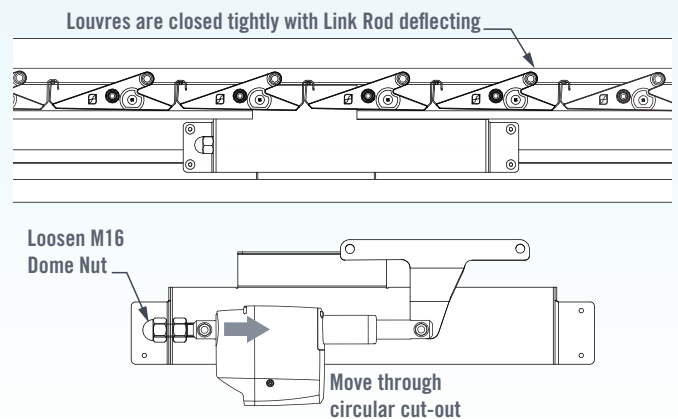

FIGURE 5.11

**RAFTER FLASHING INSTALLATION**

Select the appropriate installation section relative to the configuration of the Outback Gable Patio.

**SIDE CAPPING PREPARATION  
(COOLDEK CGI & COOLDEK CLASSIC)**

The Cooldek Side Capping will cover adjacent Cooldek and must be trimmed to allow it to fit over the Beam Cap at the Side Beam end and parallel with the Ridge Beam at the opposing end. (Figure 6.0).

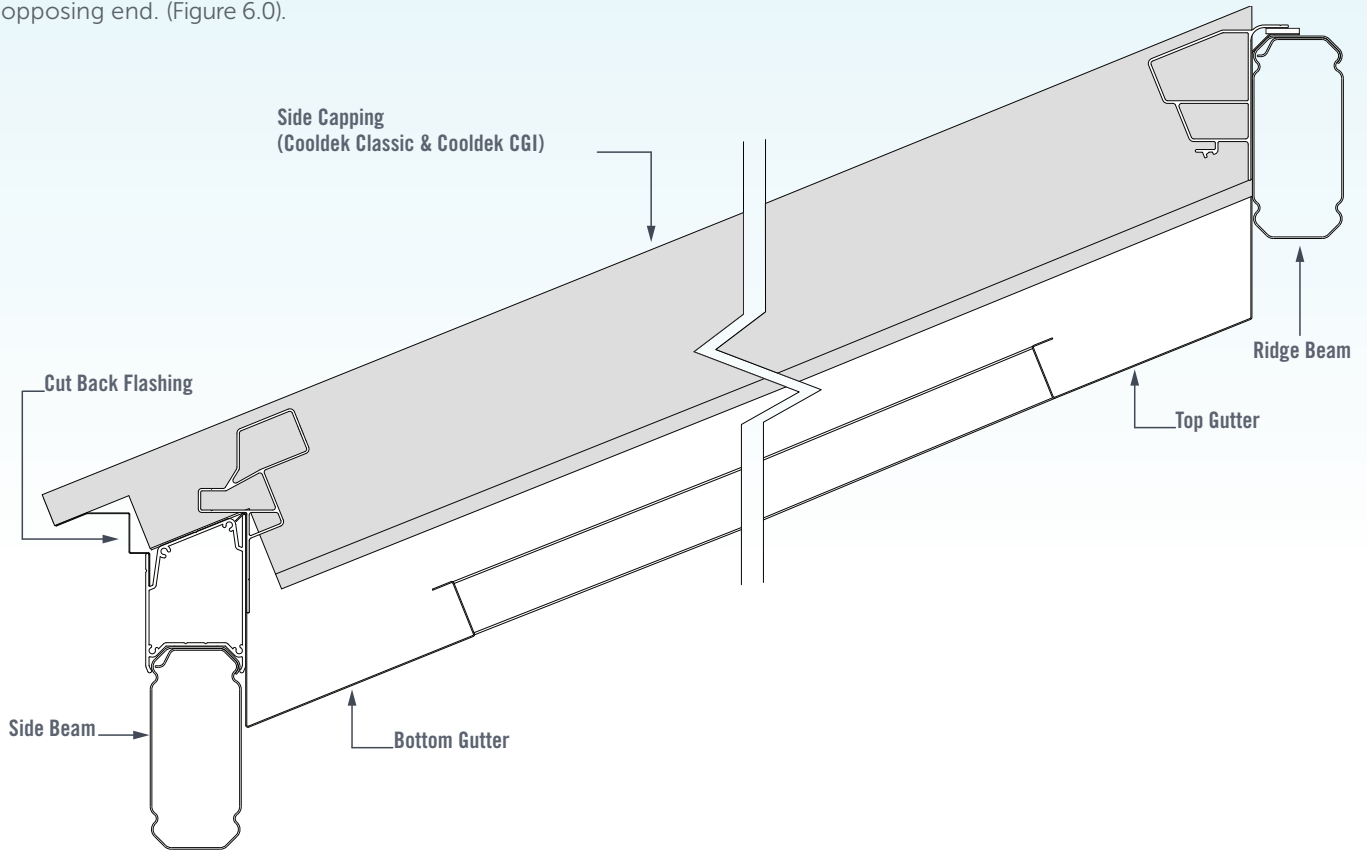

FIGURE 6.0

For Cooldek Classic Side Capping, measure and mark out trim lines as shown in (Figure 6.1).

For Cooldek CGI Side Capping, measure and mark out trim lines as shown in (Figure 6.2).

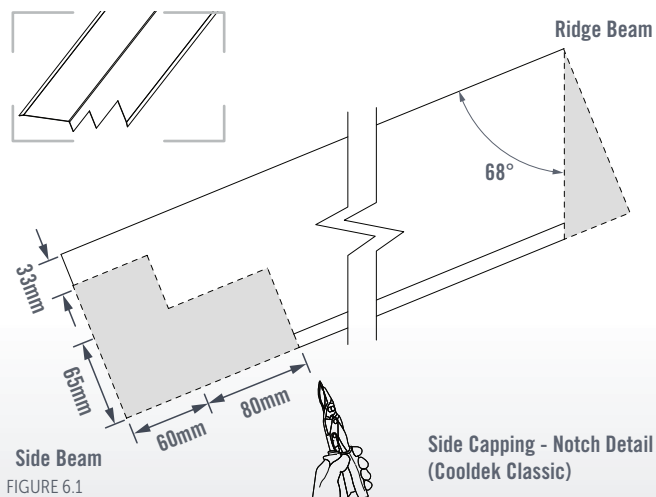

FIGURE 6.1

Using tin snips, trim marked out lines.

Slide Cooldek Side Capping into position between the Side Gutter and Louvre Extrusions (Figure 6.0).

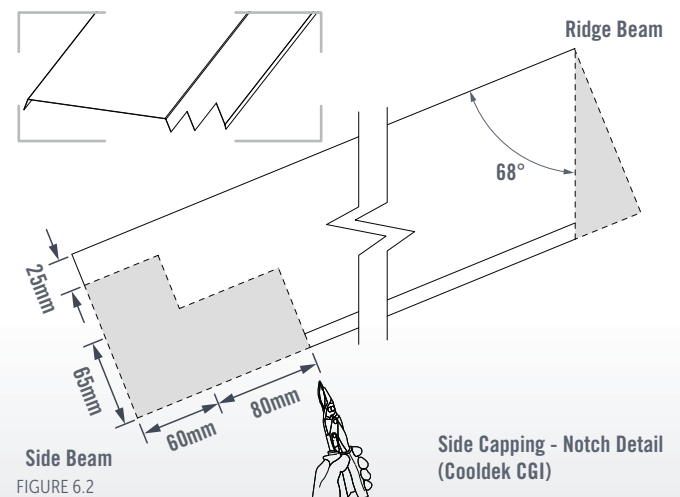

FIGURE 6.2

Fix through the internal face of the Side Capping to the Side Gutter and Rafter using Outback Self-Drilling Screws at 500mm centres (Figure 6.3 & 6.4).

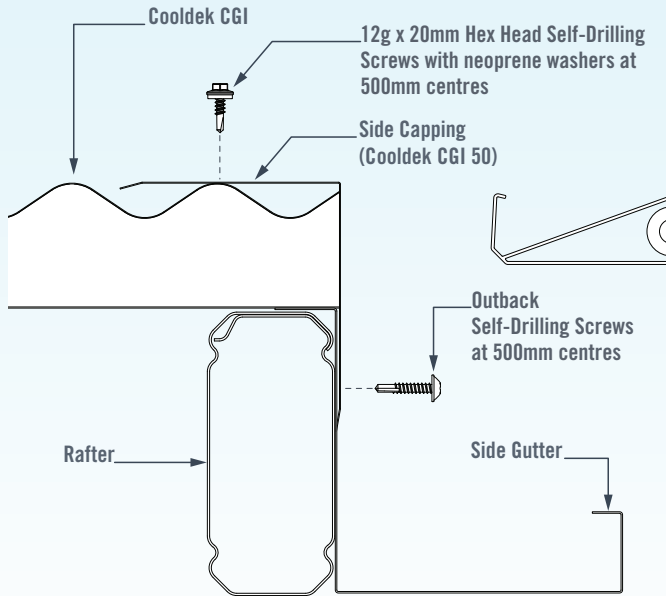

FIGURE 6.3

Fix Through the top face of the Side Capping into the crest of Cooldek using 12g x 20mm hex head self-drilling screws with neoprene washers at 500mm centres (Figure 6.3 & 6.4).

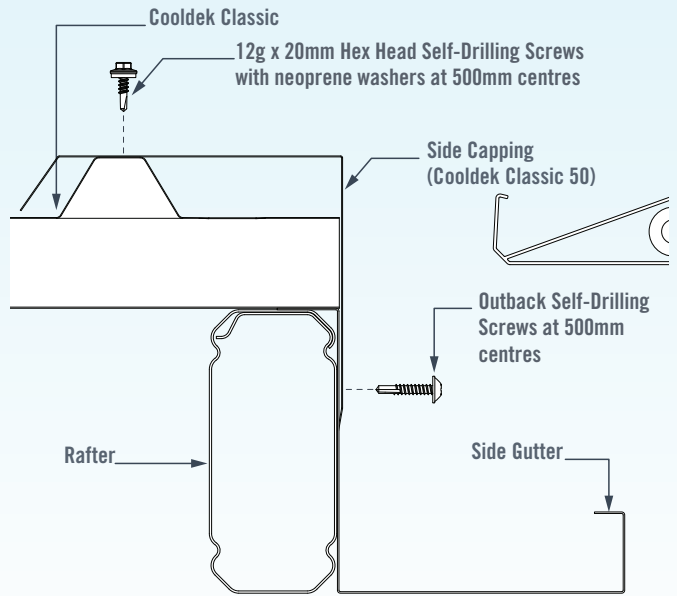

FIGURE 6.4

### SIDE CAPPING PREPARATION (CGI)

The CGI Side Capping will cover adjacent CGI roofing and must be trimmed to allow it to fit over the Beam Cap at the Side Beam end and parallel with the Ridge Beam at the opposing end. (Figure 6.5).

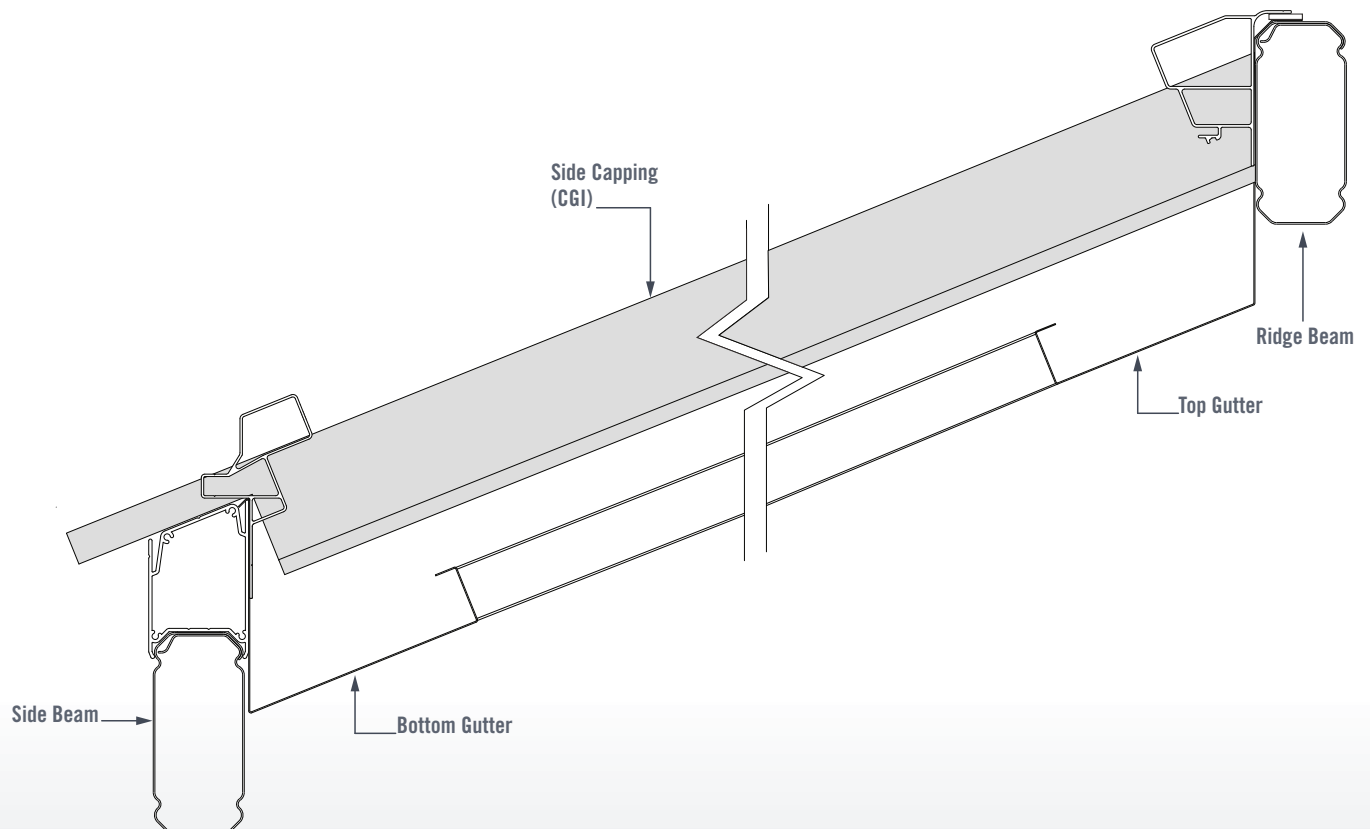

FIGURE 6.5

# OUTBACK® GABLE SUNROOF INSTALLATION GUIDE

Measure and mark out trim lines as shown in (Figure 6.6).

Using tin snips, trim marked out lines.

Slide CGI Side Capping into position between the Side Gutter and Louvre Extrusions (Figure 6.5).

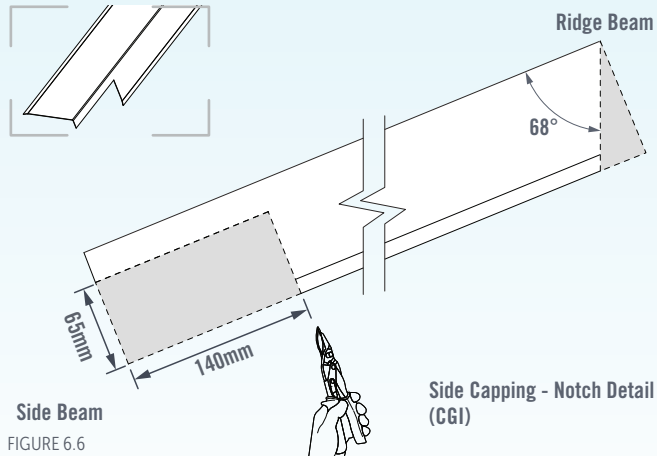

Fix through the internal face of the Side Capping to the Side Gutter and Rafter using Outback Self-Drilling Screws at 500mm centres (Figure 6.7). Fix Through the top face of the Side Capping into the crest of the CGI nearest the Rafter using  $\varnothing 3.2\text{mm}$  rivets at 500mm centres (Figure 6.7).

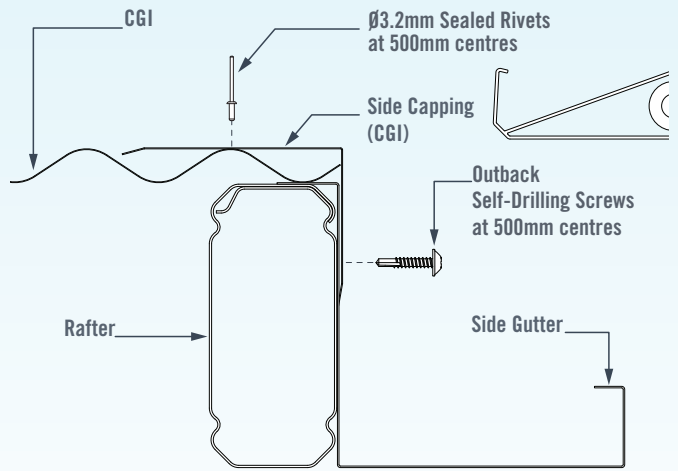

## RAFTER FLASHING PREPARATION (OUTBACK DECK)

The Outback Deck Rafter Flashing will cover adjacent Outback Deck and must be notched to allow it to fit into position. (Figure 6.8).

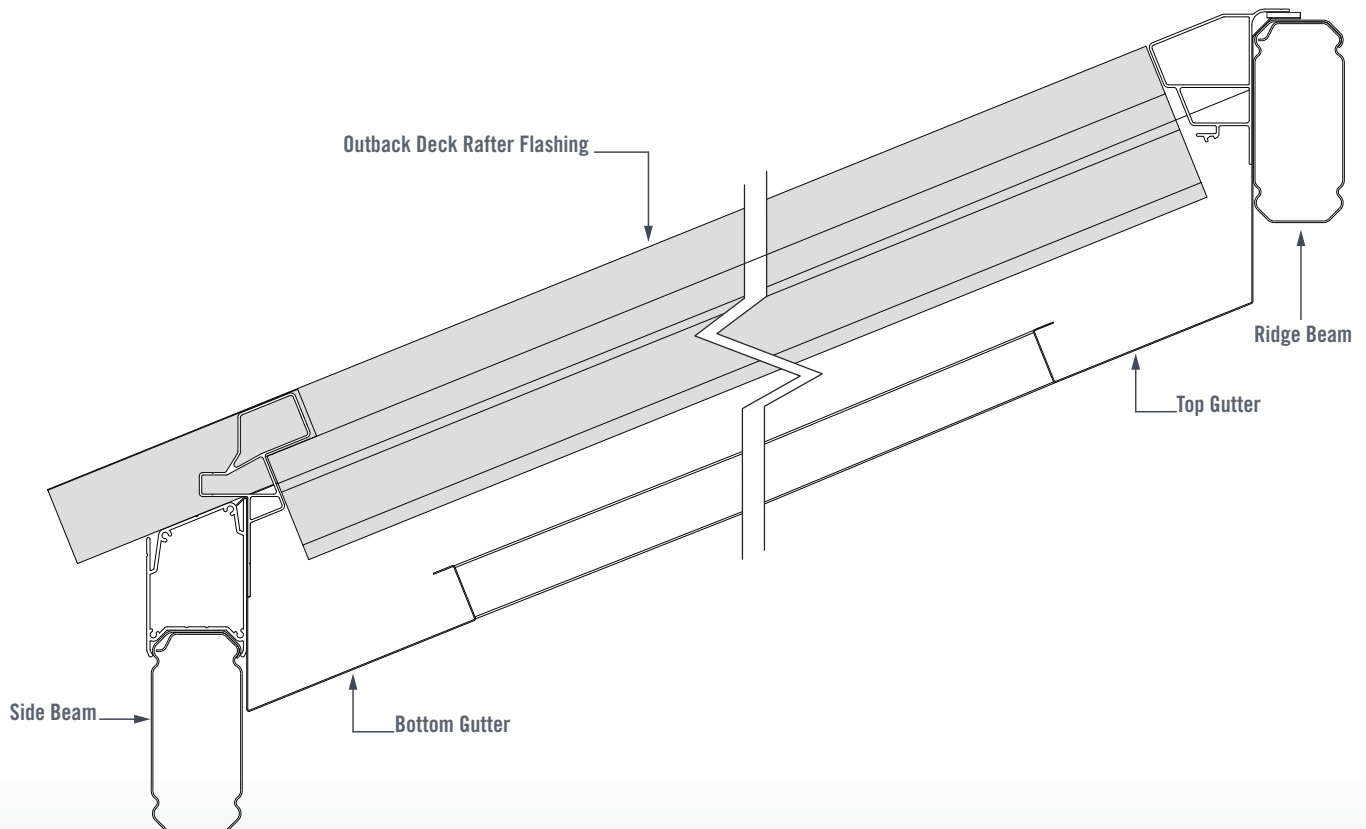

Measure and mark out trim lines as shown in (Figure 6.9).

Using tin snips, trim marked out lines.

Slide Rafter Flashing Side Capping into position between the Side Gutter and Louvre Extrusions (Figure 6.8).

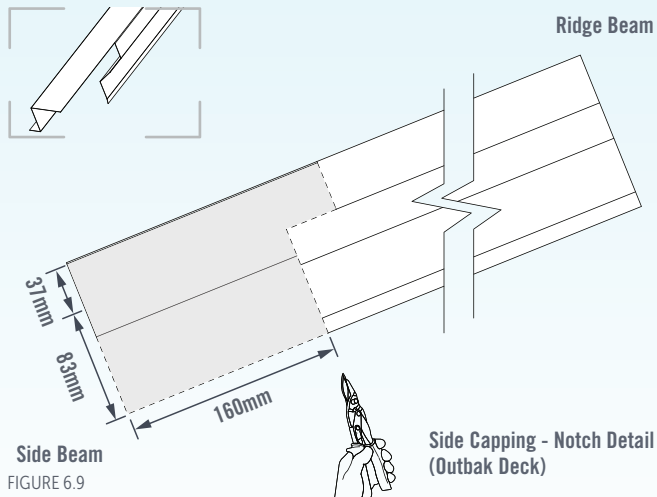

FIGURE 6.9

Fix through the internal face of the Rafter Flashing to the Side Gutter and Rafter using Outback Self-Drilling Screws at 500mm centres (Figure 6.10). Fix Through the rear lip of the Rafter Flashing into the Rafter using 12g x 20mm hex head self-drilling screws with neoprene washers at 500mm centres (Figure 6.10).

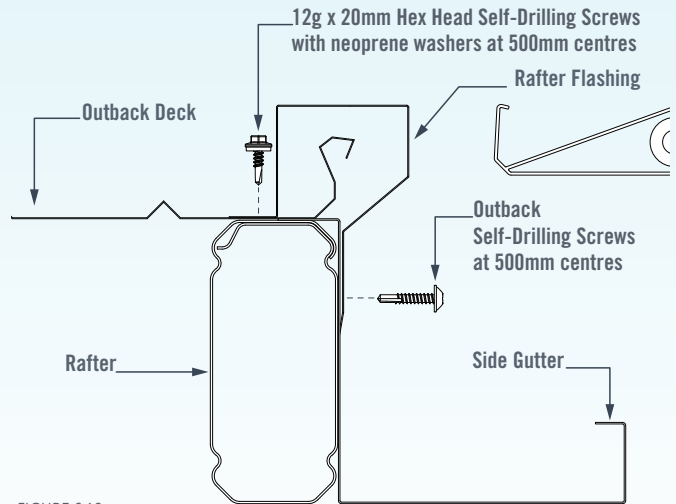

FIGURE 6.10

### END RAFTER FLASHING INSTALLATION

Where Sunroof Banks finish at an end rafter, Rafter Flashings are required on the end Rafters facing in towards the Louvres. Mount the Rafter Flashings over the rafter (Figure 6.11).

Fix through the internal face of the gutter and the top face of the Rafter with Outback Self-Drilling Screws at 500mm centres (Figure 6.11).

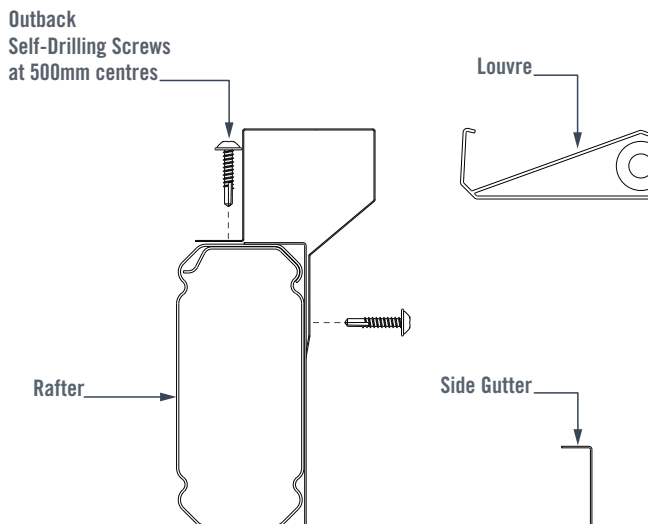

FIGURE 6.11

### DOUBLE RAFTER FLASHING INSTALLATION

For units with multiple Sunroof Banks split by an adjacent rafter, a Double Rafter Flashing will be required.

Position the Double Rafter Flashing between the top and bottom Louvre Extrusions. The top face should be 60mm from the top of the Rafter (Figure 6.12).

Fix through both sides using Outback Self-Drilling Screws at 500mm centres Figure 6.12).

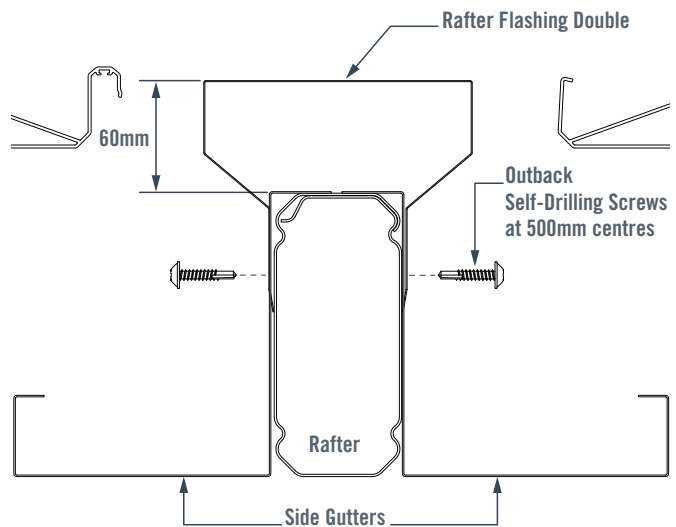

FIGURE 6.12

## BEAM CAP FLASHING INSTALLATION

Select the appropriate installation section relative to the configuration of the Outback Gable Patio.

All figures show Large Beam-Capping unless installation details differ between Large and Small Beam-Capping.

### BEAM CAP FLASHING INSTALLATION (NO ADJACENT ROOF DECKING)

Position the Cover Flashing on top of the Bottom Louvre Extrusion and centrally between Rafters.

Fix into the Bottom Louvre Extrusion using 12g x 20mm Hex Head Self-Drilling Screws with neoprene washers at 500mm centres (Figure 7.0).

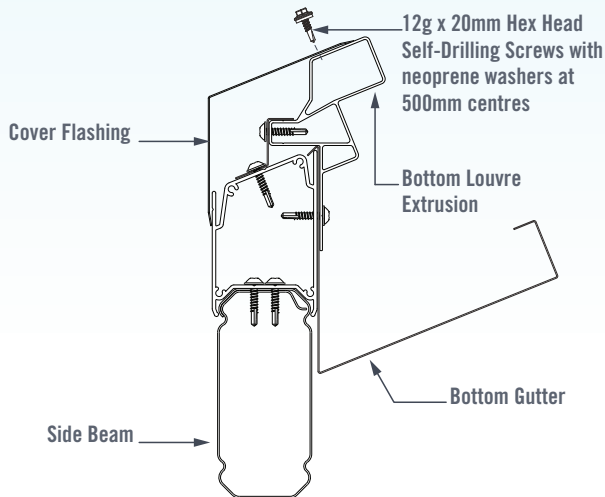

FIGURE 7.0

### BEAM CAP FLASHING INSTALLATION (ADJACENT OUTBACK DECK)

Note: Install Edge Gutter to Outback Gable Patio before completing this step.

Position the Cover Flashing on top of the Bottom Louvre Extrusion and centrally between Rafters.

Fix into the Bottom Louvre Extrusion using 12g x 20mm Hex Head Self-Drilling Screws with neoprene washers at 500mm centres (Figure 7.1).

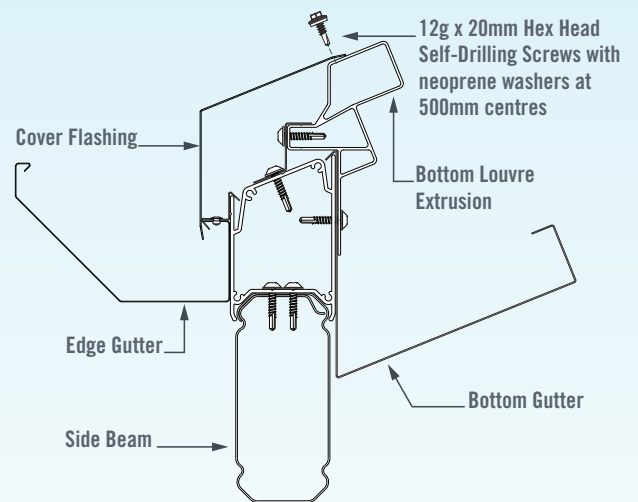

FIGURE 7.1

### BEAM CAP FLASHING INSTALLATION (ADJACENT COOLDEK CGI & COOLDEK CLASSIC)

Note: Install Edge Gutter to Outback Gable Patio before completing this step.

Hook the Cover Flashing (Cutback) over lip of the Cutback Flashing. Position the opposing end of the Cover Flashing (Cutback) on top of the Bottom Louvre Extrusion.

Fix into the Bottom Louvre Extrusion using 12g x 20mm Hex Head Self-Drilling Screws with neoprene washers at 500mm centres (Figure 7.2).

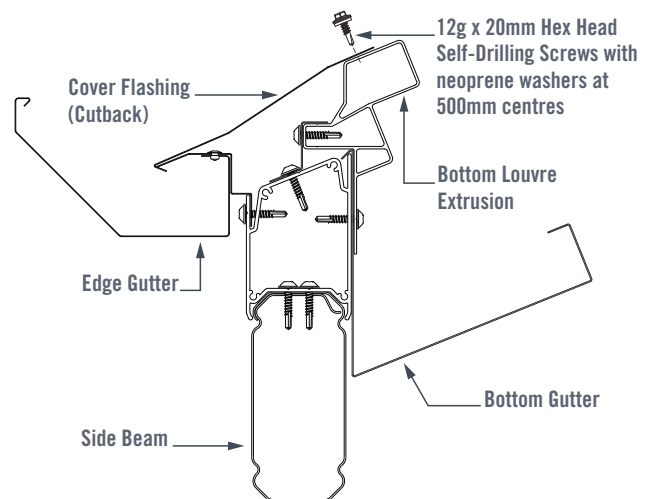

FIGURE 7.2

## RIDGE CAP FLASHING INSTALLATION

Select the appropriate installation section relative to the configuration of the Outback Gable Patio.

### RIDGE CAPPING INSTALLING

#### (LOUVRE BANK ON BOTH SIDES OF RIDGE BEAM)

Place the Ridge Cap centrally over the ridge so that it rests flat on either side of the Top Louvre Extrusions.

Ensure the Ridge Cap is centred at both ends of the Sunroof Bank and runs parallel with the ridge.

Use a string line to mark out the Ridge Cap fixing locations to ensure the screws are aligned.

Fix the Ridge Cap to the Top Louvre Extrusions using 12g x 20mm Hex Head Self-Drilling Screws with neoprene washers at maximum 500mm centres (Figure 8.0).

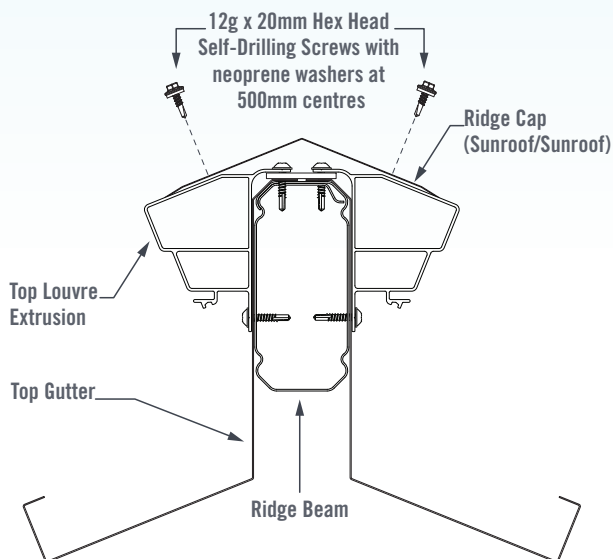

FIGURE 8.0

### RIDGE CAPPING INSTALLATION

#### (LOUVRE BANK ON ONE SIDE OF RIDGE BEAM)

Place the Ridge Cap over the ridge so that the apex is centrally aligned.

Ensure the Ridge Cap is centred at both ends of the Sunroof Bank and runs parallel with the ridge.

Adjacent Ridge Caps should overlap the Louvre Bank Ridge Cap to prevent water ingress.

Use a string line to mark out the Ridge Cap fixing locations to ensure the screws are aligned.

Fix the Ridge Cap to the Top Louvre Extrusions using 12g x 20mm Hex Head Self-Drilling Screws with neoprene washers at maximum 500mm centres (Figure 8.1-8.3).

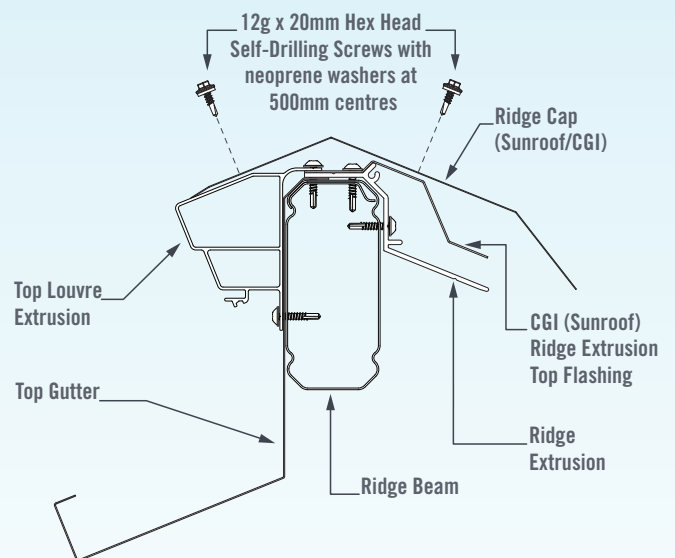

FIGURE 8.1

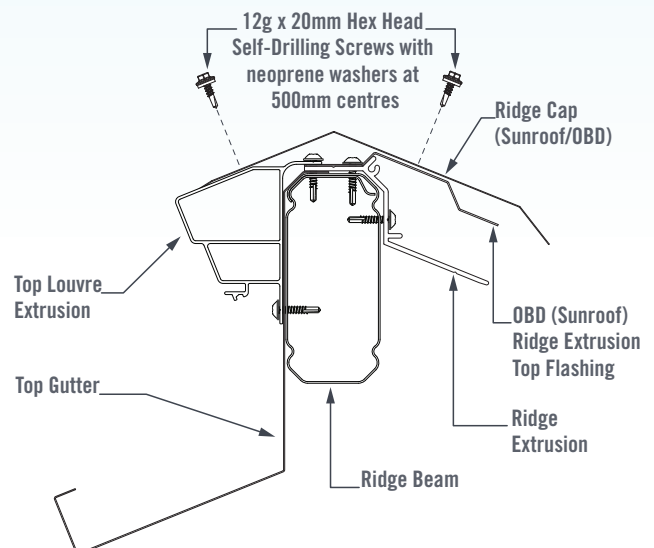

FIGURE 8.2

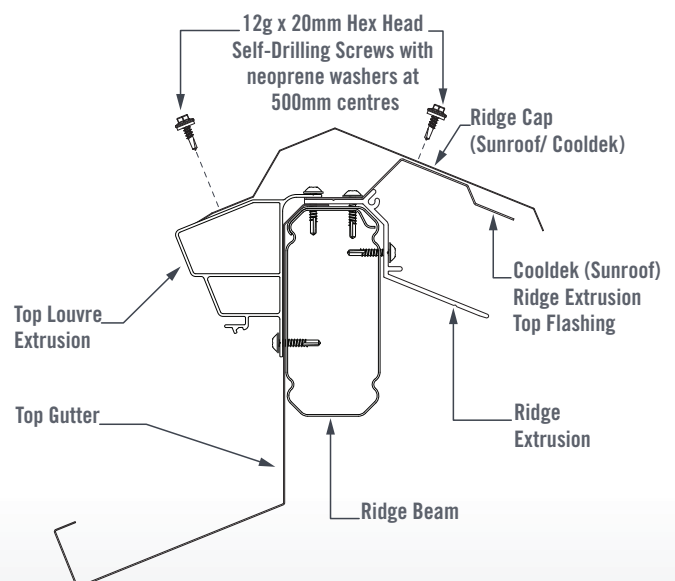

FIGURE 8.3

## LOUVRE FLASHING INSTALLATION

### LINK ROD FLASHING INSTALLATION

Install Link Rod Flashings along the Link Rods at both ends of the Louvres. Fix with rivets at 500mm centres (Figure 9.0).

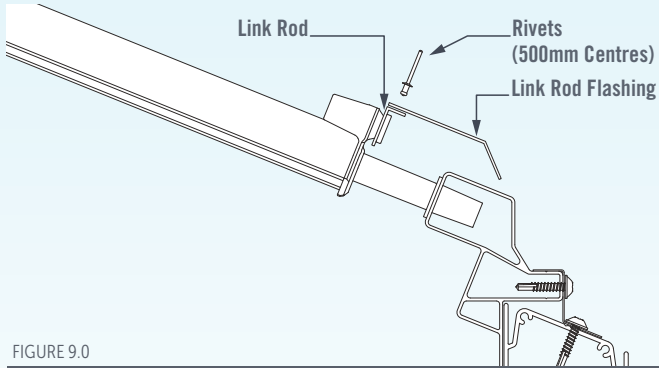

FIGURE 9.0

### CLOSING UP/CLOSING DOWN FLASHING INSTALLATION

At the 'closing-down' end of the Sunroof Bank, a Closing-Down Flashing is fixed to the top of the Rafter Flashing (Figure 9.1).

At the 'closing-up' end of the Sunroof, a Closing-Up Flashing is fixed to the top of the Rafter Flashing or Side Capping (Figure 9.2).

Note: Where a Sunroof Bank ends adjacent to a solid roof type, the respective Closing-Up or Closing-Down Flashing will be mounted atop the Side Capping. Installation sequence remains the same.

Position the Closing-Up or Closing-Down flashings between the Top and Bottom Louvre Extrusions with one end butted against the Top Louvre Extrusion.

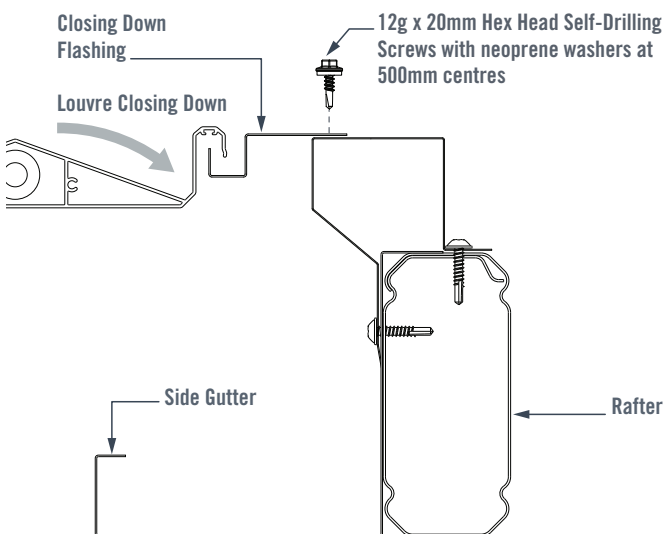

FIGURE 9.1

This should result in a gap at the Bottom allowing any water caught on the flashing to fall into the Bottom Gutter.

Fix flashings along the length of each gable rafter using 12g x 20mm Hex Head Self-Drilling Screws with neoprene washers at 500mm centres.

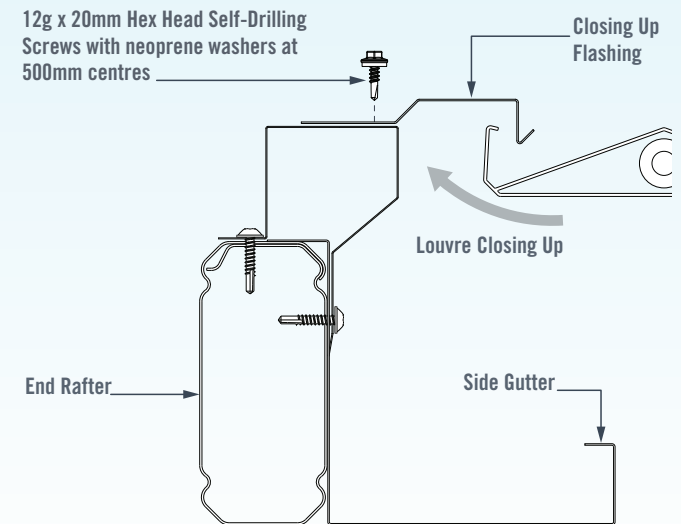

FIGURE 9.2

## RIDGE SHROUD FLASHING INSTALLATION (OPTIONAL)

Install the Shroud Mounting Brackets with even spacing onto the underside of the Ridge Beam between the Top Gutters with two Outback Self-Drilling Screws per bracket. (Figure 10.0).

Pre-drill a  $\varnothing 3.5$  hole in the Ridge Shroud at each Shroud Mounting Bracket location. Lift the Ridge Shroud into position and fix using  $\varnothing 3.2$ mm rivets (Figure 10.0).

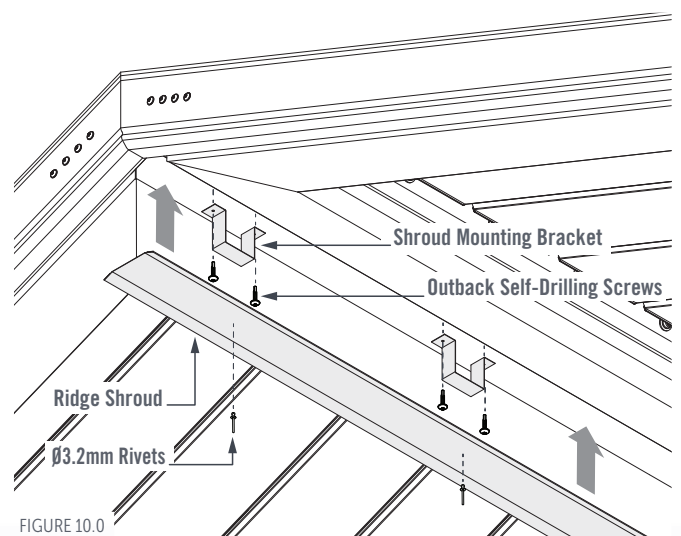

FIGURE 10.0

## BARGE TRIM INSTALLATION

Where Sunroof Banks finish at an end rafter, a Barge Trim is required.

Depending on the type of roof decking on the opposing side of the Ridge, the Barge Trim profile may differ slightly from the profile shown in Figure 11.0. The installation sequence will remain the same.

Push the Barge Trim so that it locates between the external lip of the Rafter Flashing and the top face of the Rafter (Figure 11.0).

Fix the top of the Barge Trim through the Rafter Flashing using 12g x 20mm Hex Head Self-Drilling Screws with neoprene washers at 500mm centres (Figure 11.0).

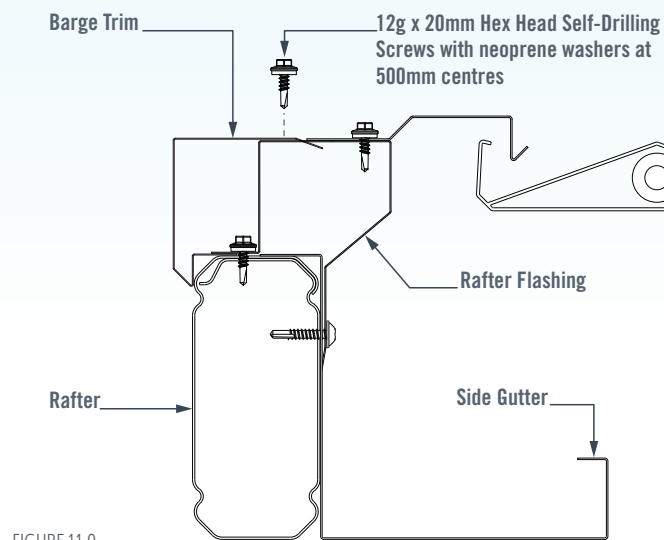

FIGURE 11.0

## DOWNPIPE INSTALLATION

Before attaching the downpipe, fix the downpipe bracket(s) to the Column (Figure 12.0).

Note: The downpipe Bracket shown is for use with round Downpipe. If using a 100x50mm Downpipe, the Installation sequence will remain the same.

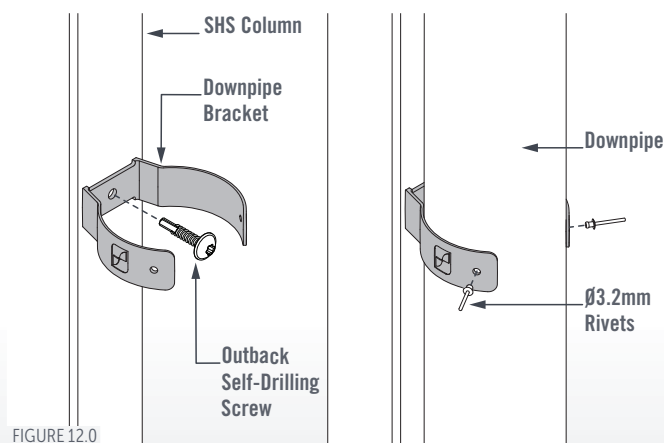

FIGURE 12.0

Slide the downpipe over the previously installed Downpipe Outlet and rivet into position. If Downpipe Elbow joints are required, connect as required to ensure the Downpipe aligns parallel to the SHS Column.

Rivet the downpipe to the downpipe bracket (Figure 12.0). Weatherproof all fasteners with silicone.

Note: If your Sunroof unit has multiple louvre banks, each bank will require a downpipe.

## RAIN SENSOR

Select a flat area on the unit or adjacent structure that is open to the weather and does not interfere with the louvre rotation and fix the rain sensor mounting bracket using two appropriate fasteners with Neoprene Washers (Figure 12.1).

Run the rain sensor cable back to the control box (an extension cord is provided if needed). The rain sensor cable will be identified by the use of three pins in the connectors. Use rubber cable grommets within holes in the framework as required. Simply plug the cable into the corresponding four pin connection at the end of the control box. Finally, tighten the plastic locking nut.

Due to the sensitive nature of the sensor, it is likely that on occasion, small creatures, including skinks, geckos, spiders or birds will inadvertently trigger the sensor and close the roof.

While the rain sensor is activated, during a rain event, the remote control will not activate the roof. The roof control unit (not the remote control) will emit a sharp 'beep' if the rain sensor is activated and a button is pressed on the remote control.

Once the sensor has returned to normal (rain has cleared) for a minimum of 30 seconds, the rain alarm is cancelled. The roof will not open automatically.

It is recommended that after a rain event, open the roof to approximately 30° to allow the rain water to run off the blades and to drain to the gutters.

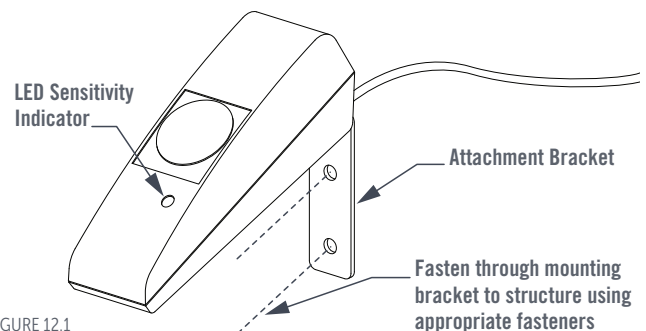

FIGURE 12.1

## FINAL FIXING

Replace the temporarily removed fixings from the inside faces of the Rafters and Rafter-to-Beam Brackets (Figure 1.2, Page 3).

**TROUBLESHOOTING**

PROBLEM	CHECK	POSSIBLE CAUSE	REMEDY	
The louvres will not move when the "OPEN" or "CLOSE" buttons on the remote control are pressed.	The red LED light on the remote control unit should illuminate when any of the buttons are pressed.	Flat battery in remote control unit.	Replace battery in the remote control unit with new CR3032.	
		Faulty remote control unit.	Replace the entire controller assembly and remote control unit.	
	Switch the power off, wait a few seconds and then switch the power back on. The controller assembly should emit an audible beep when the power is turned on.	No power at 240V ac power outlet.	Check that the 240V ac power cord to the controller assembly is plugged in and the power outlet is switched on.	
			Check fuse/circuit breaker in switchboard.	
			Use another appliance to test for power at the power outlet.	
			Call an electrician if power is still not available at the power outlet.	
	Press the "OPEN" and then "CLOSE" buttons on the remote control unit. The controller assembly should emit audible clicks when the buttons are pressed one after another.	Faulty 24V dc power supply or controller assembly.	Replace the entire controller assembly and remote control unit if power is available at the power outlet and beep is not heard.	
		Wrong bank of louvres selected on the remote control unit (multiple bank patios only).	Press the left or right "SELECT" buttons until the correct channel is illuminated.	
	If the louvres are fully closed, press the "OPEN" button on the remote control unit. The controller assembly should emit an audible beep if the rain sensor has been triggered.	Faulty 24V dc power supply or controller assembly.	Replace the entire controller assembly and remote control unit if power is available at the power outlet but clicking is not heard.	
		Water or contaminants on the rain sensor.	Wait until the rain stops and the sensor dries off or if contaminated, carefully clean the rain sensor with a damp cloth and dry off.	
	Plug the actuator directly into the controller assembly to check if the extension cables or actuator are faulty.	Faulty rain sensor.	Replace rain sensor.	
		Faulty connection.	Check that the connections between the actuator, extension cable and controller assembly are secure if the actuator functions correctly when plugged directly into the controller assembly.	
			Faulty or broken extension cables.	Remove and replace the extension cable if the actuator functions correctly when plugged directly into the controller assembly.
			Faulty actuator.	Replace the actuator, if it does not function correctly when plugged directly into the controller assembly.
Disconnect the link rod from the louvres and check that each louvre rotates freely.	Louvres not square to beam, interference between components.	Square up beams or replace components as required.		

PROBLEM	CHECK	POSSIBLE CAUSE	REMEDY
The louvres open automatically when the rain sensor is triggered.	The actuator should move in the same direction when the "CLOSE" button is pressed and when the rain sensor is triggered.	The controller assembly is faulty if the actuator moves in different directions when the "CLOSE" button is pressed and when the rain sensor is triggered.	Replace the entire controller assembly and remote control unit.
		If the actuator moves in same direction when the "CLOSE" button is pressed and when the rain sensor is triggered.	Refer to the remedies for louvres moving in the wrong direction
The louvres will not close automatically when the rain sensor is triggered.	Plug the rain sensor directly into the controller assembly to check if the extension cables or rain sensor are faulty.	Hold the "STOP" button down for 10 seconds. The controller assembly emits two beeps when the rain sensor is manually turned off and a long continuous beep when the rain sensor is turned back on.	Hold the "STOP" button down for 10 seconds. The controller assembly will emit a long continuous beep when the rain sensor is turned back on.
		Faulty connection.	Check that the connections between the rain sensor, extension cable and controller assembly are secure if the rain sensor functions correctly when plugged directly into the controller assembly.
		Faulty or broken extension cables.	Remove and replace the extension cable if the rain sensor functions correctly when plugged directly into the controller assembly.
		Faulty rain sensor.	Replace the rain sensor if it does not function correctly when plugged directly into the controller assembly.
		Faulty controller assembly.	Replace the entire controller assembly and remote control unit if another rain sensor does not function correctly when plugged directly into the controller assembly.
Actuator assembly is the opposite 'Type' (A or B) required for Louvre opening direction. 'OPEN' closes louvres; 'CLOSE' opens louvres.	Original design plans for designated Actuator assembly placement and Louvre opening direction	Louvres have been installed to open in the opposite direction to the original unit design.	Contact Stratco to advise in reversing the Remote Control operations within the Control Box.
		The Actuator assembly has been placed on the opposing side to the original unit design designation.	
The louvres move in the wrong direction when the "OPEN" or "CLOSE" buttons on the remote control are pressed.	The actuator should retract when the "OPEN" button is pressed and extend when the "CLOSE" button is pressed.	Cable connector plugged in backwards.	Check that the rib inside the connector with pins is aligned with the groove on the connector with sockets.
		Mechanism installed incorrectly.	Check that the mechanism is installed as per the installation guide.
		Actuator, extension cable or controller assembly wired incorrectly.	Remove cover from controller, disconnect red and black actuator cables from terminals labelled OPEN and CLOSE, swap them over and reconnect them in the terminal block.



## **MAINTENANCE**

Regular maintenance is essential to maintain the good looks of all Stratco steel products and to ensure you receive the maximum life-span possible.

Washing with clean water must be frequent enough to prevent the accumulation of dust, salts, and pollutants that may reduce the life of the product.

Stratco steel products that are regularly washed by rain require no additional maintenance.

No Stratco steel structure or materials are recommended for use over, or in close proximity, to swimming pools or spas.

No material that retains water (such as dirt or paving sand) should be placed against the columns.

Care must be taken when determining the location of Stratco steel products so that they are not placed in close contact with sources of pollution or environmental factors that could affect the life of the steel. Refer to the 'Selection, Use and Maintenance' brochure for more information.

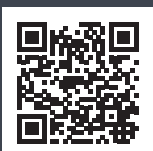

« SCAN THIS QR CODE TO FIND A STRATCO NEAR YOU

**1300 155 155**  
**stratco.com.au**

All brands and logos/images accompanied by ® or ™ are trade marks of Stratco (Australia) Pty Limited. © Copyright February 2024

**How To.**

