

Overflow Solutions

Stratco Domestic Gutter Information Guide



Gutter Overflow Provisions

It is important when designing a roof drainage system that appropriate overflow measures are considered in order to ensure water does not flow back into the building. This is particularly important for the most commonly used eaves gutters which are high fronted and designed to hide the lower edge of the roof tiles or cladding. This often results in the front edge of the gutter sitting at or above the top of the fascia level.

This document has been developed by Stratco for compliance with the current version (NCC 2022) of the Building Code of Australia (BCA) - Volume 2 which requires that adequate overflow measures are applied. This requirement ensures overflow resulting from rainfall calculated at a 5 minute rainfall intensity duration, for a 100 year average recurrence interval (refer Table 1.0), is diverted away from the building. Information taken from the NCC 2022 BCA - Volume 2 has been included (Tables 2.0 & 3.0) to allow the appropriate overflow volumes to be calculated in order to apply a selection of acceptable overflow measures. These measures may be applied individually or in combination to achieve the required overflow capacity.

Responsibility of the Designer

It is the responsibility of the designer of the rainwater goods system (who may be the architect, builder, hydraulic engineer, home owner, roofing or guttering contractor) to design a rainwater system which allows adequate drainage to occur.

The design and installation of guttering and downpipe systems needs to comply with the Building Code of Australia and Australian Standards AS/NZS 3500.3 Plumbing and Drainage, Stormwater Drainage.

Responsibility of the Installer

It is the responsibility of the installer to ensure the project is installed as required by the rainwater goods designer. Adequate fall towards the downpipes must be given to gutters (a minimum of 1 in 500 for eaves gutters and 1 in 200 for internal gutters).

The installer must ensure that the correct number of downpipes of sufficient size are installed, that they are clear of debris and able to discharge correctly.

Maintenance

Regular maintenance is essential to maintain the good looks of all Stratco steel products and the ensure you receive the maximum life-span possible in your area. Gutter systems must be regularly cleaned to prevent the build up of leaf debris, fungus or any other material that could prevent the free drainage of water from the roof and gutter system.

Refer to the Stratco 'Selection, Use and Maintenance' brochure for further information.

Overflow Solutions Domestic Gutter Information Guide

Table 1.0: Design Rainfall Intensities (mm/h)

Average Recurrence: Once In 100 Years (Eaves Gutter Overflow Measures)

Location	5 Minute Duration Rainfall Intensity (mm/h)	Location	5 Minute Duration Rainfall Intensity (mm/h)
New South Wales		Queensland	
Albury	180	Bamaga	298
Broken Hill	217	Brisbane	306
Goulburn	154	Ipswich	278
Kiama	320	Victoria Point	320
Newcastle	316	Bundaberg	339
Orange	186	Cairns	279
Sydney	262	Cloncurry	278
Avalon	287	Innisfail	302
Campbelltown	223	Mackay	315
Penrith	240	Mt Isa	262
Windsor	234	Noosa Heads	332
Tweed Heads	332	Rockhampton	300
Wollongong	311	Toowoomba	268
Western Australia		Townsville	300
Albany	179	Weipa	281
Broome	287	Victoria	
Bunbury	198	Ballarat	192
Derby	256	Benalla	194
Geraldton	194	Geelong	143
Kalgoorlie	204	Horsham	173
Perth	172	Lakes Extranace	199
Joondalup	180	Melbourne	187
Midland	164	Hastings	145
Port Hedland	232	Sorrento	140
Tom Price	182	Mildura	219
South Australia		Stawell	187
Adelaide	174	Tasmania	
Gawler	158	Burnie	178
Mount Gambier	144	Flinders Island	167
Murray Bridge	177	Hobart	120
Port Augusta	199	Launceston	123
Port Pirie	183	Queenstown	120
Yorke town	166	St. Mary's	207
Australian Capital Territory		Northern Territory	
Canberra	192	Alice Springs	239
Gungahlin	179	Darwin	274
Tuggeranong	210	Katherine	250

NOTE:

- Data obtained from NCC 2022 BCA - Volume 2
- Data for any locality in Australia is available from the Bureau of Meteorology.
- All gutters and outlets need to be regularly inspected and maintained to avoid blockages.

Table 2.0: Continuous Overflow Volume (L/s/m)

Rainfall Intensity (mm/h) <i>(from Table 1.0)*</i>	Ridge to Gutter Length (m)							
	2	4	6	8	10	12	14	16
150	0.08	0.17	0.25	0.33	0.42	0.50	0.58	0.67
175	0.10	0.19	0.29	0.39	0.49	0.58	0.68	0.78
200	0.11	0.22	0.33	0.44	0.56	0.67	0.78	0.89
225	0.13	0.25	0.38	0.50	0.63	0.75	0.88	1.00
250	0.14	0.28	0.42	0.56	0.69	0.83	0.97	1.10
275	0.15	0.31	0.46	0.61	0.76	0.92	1.10	1.20
300	0.17	0.33	0.50	0.67	0.83	1.00	1.20	1.30
325	0.18	0.36	0.54	0.72	0.90	1.10	1.30	1.40
350	0.19	0.39	0.58	0.78	0.97	1.20	1.40	1.60
375	0.21	0.42	0.63	0.83	1.00	1.30	1.50	1.70
400	0.22	0.44	0.67	0.89	1.10	1.30	1.60	1.80

*Round value up to nearest 25mm/hr increment

Table 3.0: Dedicated Overflow Volume (L/s)

Rainfall Intensity (mm/h) <i>(from Table 1.0)*</i>	Roof Catchment Area (m ²)				
	30	40	50	60	70
150	1.3	1.7	2.1	2.5	2.9
175	1.5	1.9	2.4	2.9	3.4
200	1.7	2.2	2.8	3.3	3.9
225	1.9	2.5	3.1	3.8	4.4
250	2.1	2.8	3.5	4.2	4.9
275	2.3	3.1	3.8	4.6	5.3
300	2.5	3.3	4.2	5.0	5.8
325	2.7	3.6	4.5	5.4	6.3
350	2.9	3.9	4.9	5.8	6.8
375	3.1	4.2	5.2	6.3	7.3
400	3.3	4.4	5.6	6.7	7.8

* Round value up to nearest 25mm/hr increment

NOTE: Table 2 and 3 from NCC 2022 BCA - Volume 2

Overflow Solutions Domestic Gutter Information Guide

Continuous Overflow Solutions

The following overflow solutions provide a measure for continuous overflow for the full length in which the solution is applied. These can be applied in combination with dedicated measures if further overflow capacity is required.

Front Gutter Height

Water will overflow to the front of the gutter if the top of the front gutter bead is located below the top of the fascia. Due to the gutter fall, this may occur towards the end of a gutter run in which case the portion of gutter beginning 5mm below the top of the fascia may be used in the overflow calculations.

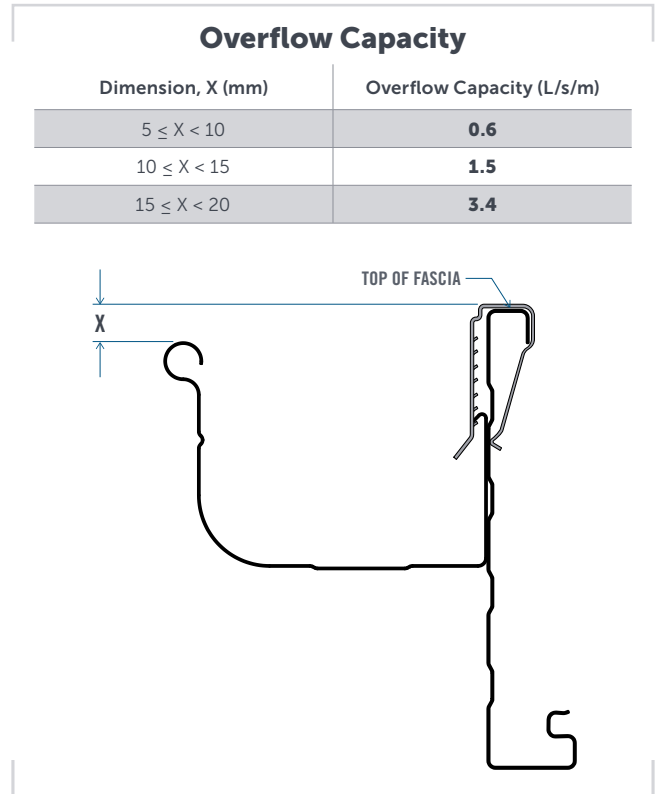
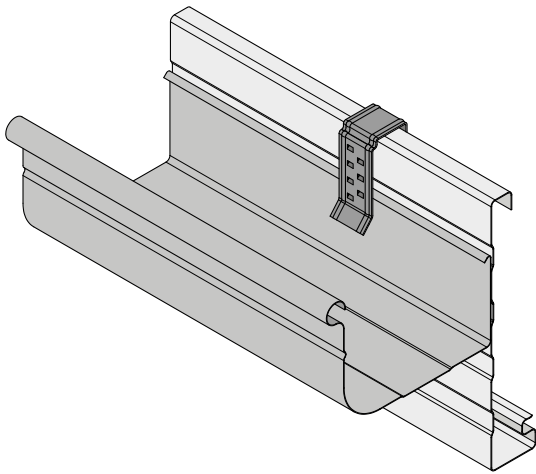

Stratco Torrent Spacer Gutter Clip

The perfect solution to create a consistent gap between the gutter and fascia, allowing water to escape through the gap rather than entering the building. The clip facilitates the required 10mm minimum distance between the top of the fascia and the back of the gutter and is available to suit Stratco Continuous steel fascia as well as timber fascia. For installation details refer to the Stratco Torrent Spacer Gutter Clip Install Guide.

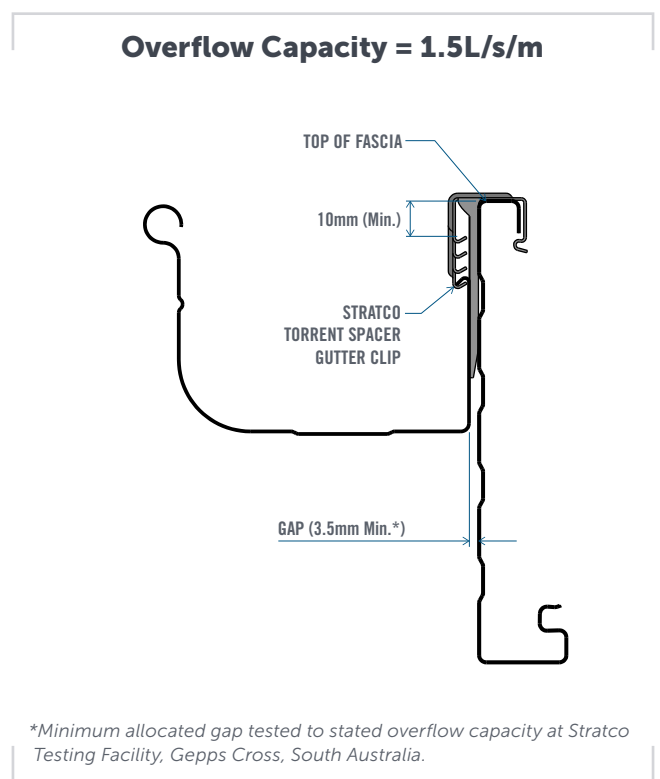
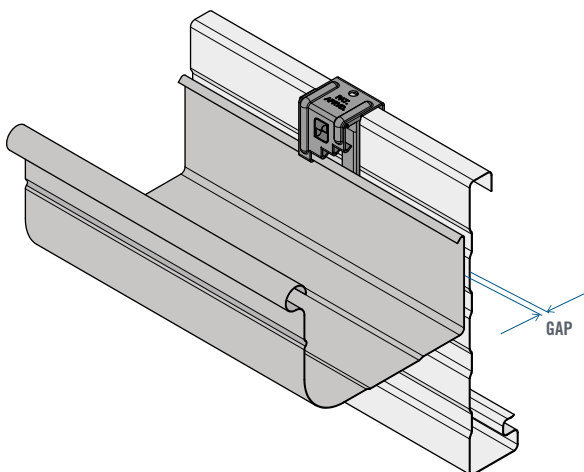

Gutter Slots

Pre-punched slots are created at 93mm intervals in the front face of the gutter and will release overflow to the front of gutters. The lowest edge of the slots shall be at least 17mm below the top of the fascia which is the minimum distance accommodated by using Stratco Gutter Suspension Clips.

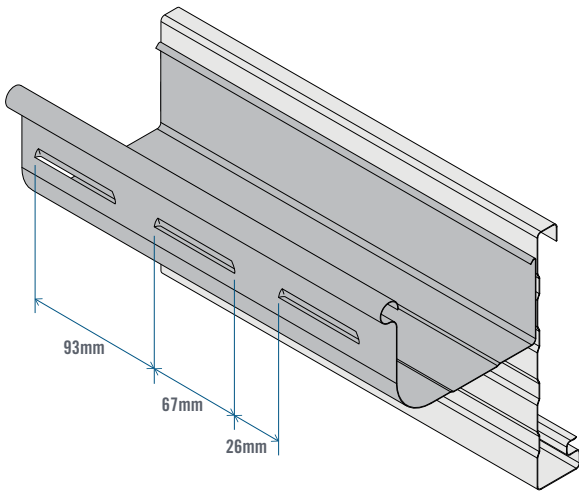

Overflow Capacity = 0.73L/s/m

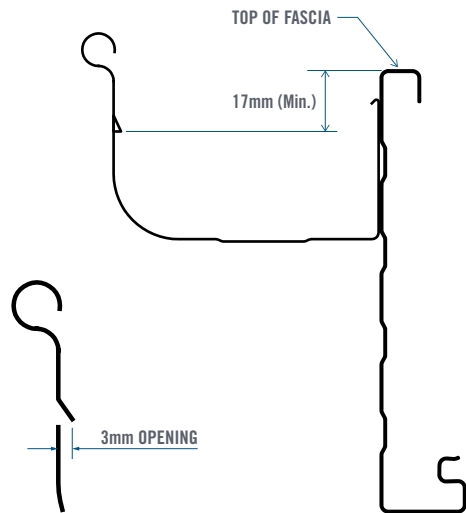

**Minimum slot set-down tested to beyond stated overflow capacity at Stratco Testing Facility, Gepps Cross, South Australia.*



Overflow Solutions Domestic Gutter Information Guide

Dedicated Overflow Solutions

The following overflow solutions will provide a dedicated overflow in litres per second for the individual measure. In some cases these measures can be located intermittently along the gutter to obtain the total overflow required or may be suitable stand-alone.

Internal Outlet

An internal outlet of dimensions 100mm x 50mm positioned lengthways in the gutter will overflow water internally from the gutter once it reaches a certain level. The top of the outlet shall be located at least 25mm below the top of the fascia.

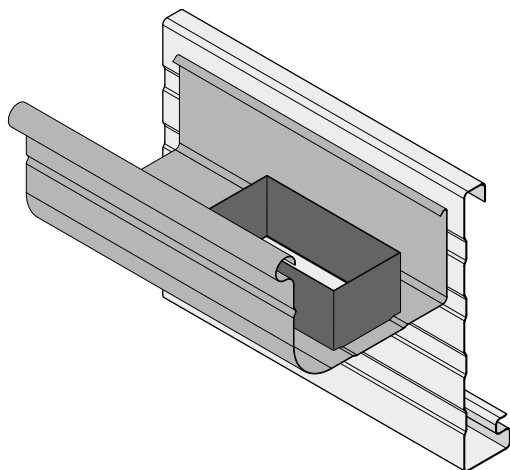

Overflow Capacity = 1.2L/s per outlet

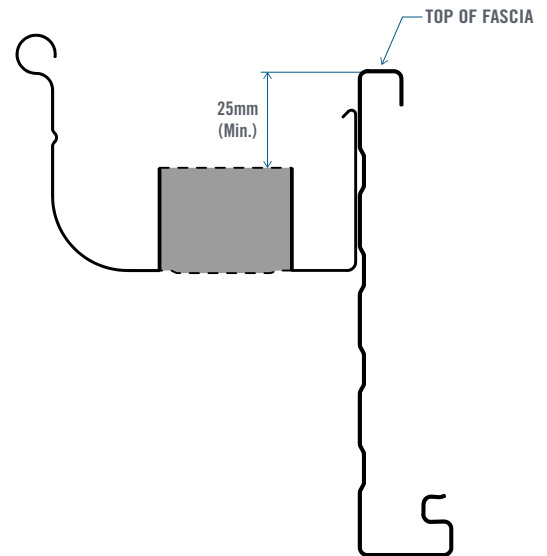

External Gutter Sump

This style of overflow device will allow water to flow directly from a hole or outlet in the gutter base to a sump immediately below.

Any overflow will occur over the top edge of the gutter sump to the front of gutters.

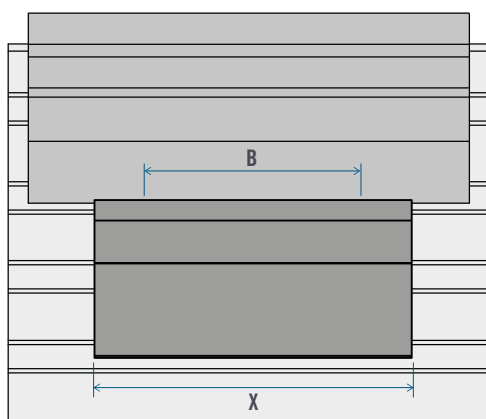
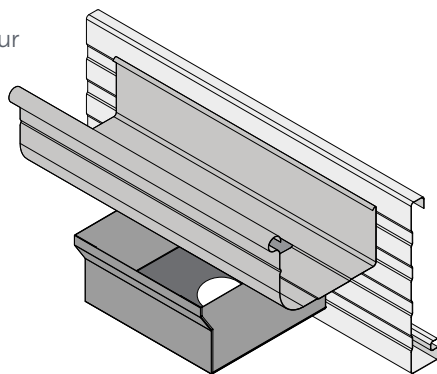

Overflow Capacity

Width, X (mm)	Minimum Gutter Hole B x D (mm)	Overflow Capacity (L/s)
225	150 x 50	4.5
300	200 x 50	6.0

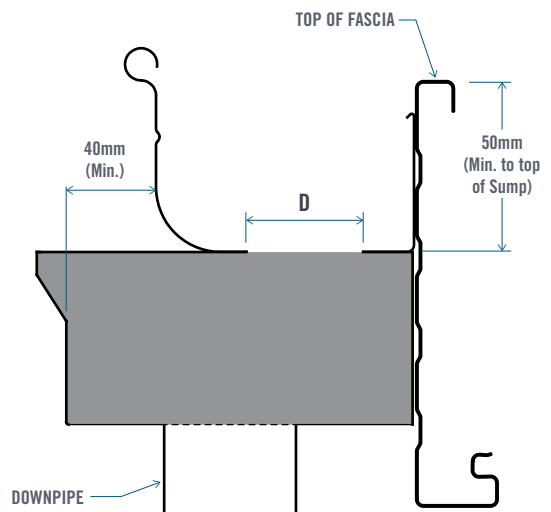

Domestic Rainhead

For a modern appeal, an aesthetically pleasing domestic rainhead can be selected to provide the full overflow allowance when designed appropriately. The overflow outlet in the rainhead shall be located at least 100mm from the top of the fascia with the base of the gutter at least 60mm from the top of the fascia.

Outlet/Slot Area, A

$$A = \pi R^2 \text{ (circular)}$$

or

$$A = B \times D \text{ (rectangular)}$$

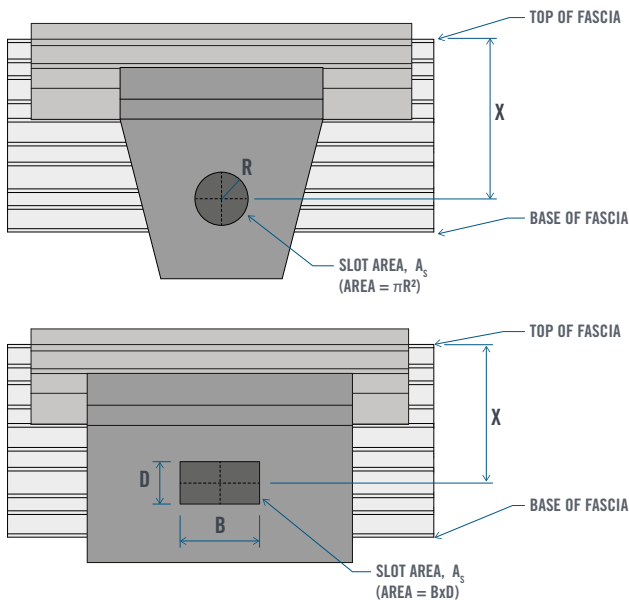

Overflow Capacity

Distance, X (mm)	Min. Gutter Outlet Area, A_g (mm ²)	Slot Area, A_s (mm ²)	Overflow Capacity (L/s)
100	6000	4500	3.8
	8000	6000	5.1
125	7000	4500	4.2
	9000	6000	5.7
150	7500	4500	4.7
	10000	6000	6.2

NOTE: For intermediate values of area, interpolation is permitted.

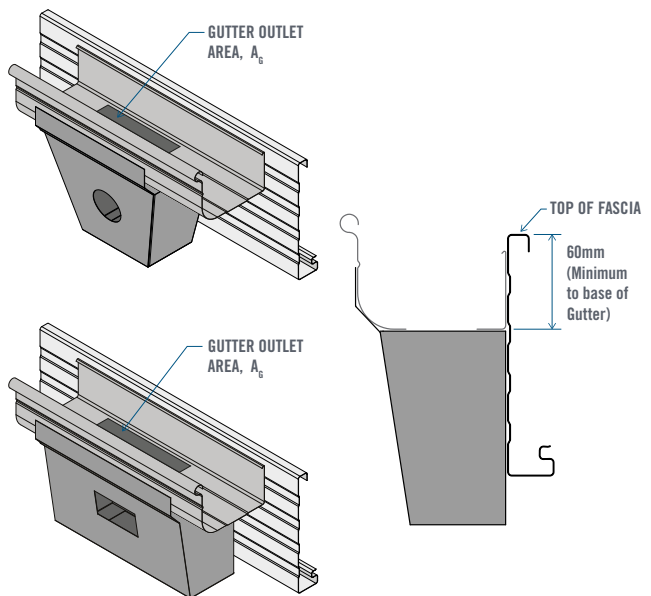

Cut-Down Stop End

As long as it is not abutting a wall, a stop end which is cut down to create a weir will allow for some additional overflow. The cut-down shall be at least 100mm wide with the lower edge at least 25mm from the top of the fascia.

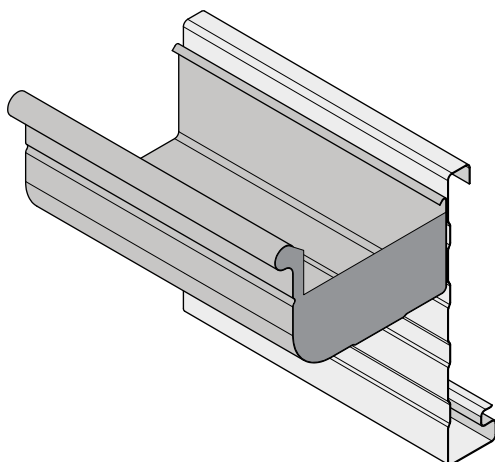

Overflow Capacity = 0.5L/s

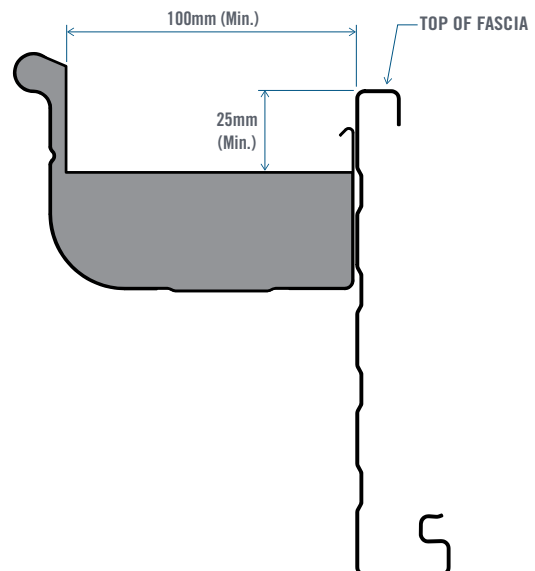

Overflow Solutions



Design Example

Consider a home located in Bundaberg, QLD.

Determine the overflow requirement for an 11m eaves gutter length with a 5m Ridge to Gutter Length.

Step 1

From Table 1.0 (or an alternative source as noted), the 5 minute duration rainfall intensity for an average recurrence interval of 100 years in Bundaberg is 339mm/h. Round this value up to the closest 25mm/h increment, i.e. 350mm/h.

Step 2

As we have the Ridge to Gutter Length of 5m, Table 2.0 is used to determine an interpolated value of 0.49L/s/m for a 350mm/h intensity.

If required, the total overflow can be determined by multiplying this volume by the gutter length, i.e. $0.49 \times 11\text{m} = 5.4\text{L/s}$.

Alternatively, if the Roof Catchment Area is known to be 55m^2 , Table 3.0 is used to determine an interpolated overflow volume of 5.4L/s for a 350mm/h intensity.

Step 3

An appropriate overflow solution can now be determined for this 11m run of gutter.

Option 1

Continuous Overflow Solution: Torrent Spacer

Consider a 3.5mm rear exit gap.

For this option the Overflow Capacity = 1.5L/s/m (refer page 4).

As $1.5 > 0.49\text{L/s/m}$ this is an acceptable solution.

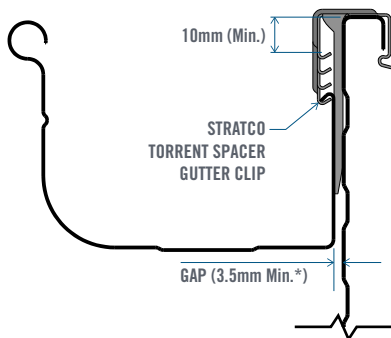

Option 2

Dedicated Overflow Solution: Rainhead

Consider a domestic rainhead at the downpipe location. Specifying a distance of 125mm from the top of the fascia to the centre of an overflow outlet of Area = 6000mm^2 , the Overflow Capacity = 5.7m/s (refer page 7). As $5.7 > 5.4\text{L/s}$ this is an acceptable solution.

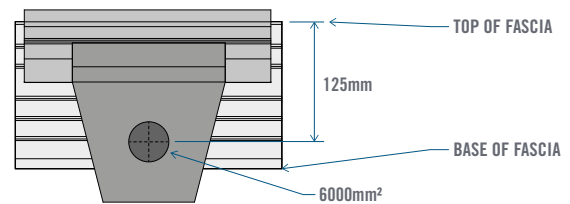

Option 3

Continuous Overflow Solution: Gutter Slots

Consider a Stratco slotted gutter.

Overflow Capacity = 0.73 L/s/m (refer page 5).

As $0.73 > 0.49\text{L/s/m}$ this is an acceptable solution.

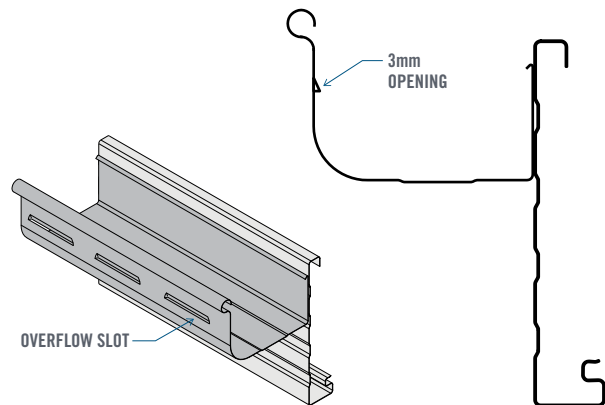

NOTE: Further options are available based on the various solutions provided in this Information Guide.



« SCAN THIS QR CODE TO FIND A STRATCO NEAR YOU

1300 155 155
stratco.com.au

All brands and logos/images accompanied by © or ™ are trade marks of Stratco (Australia) Pty Limited. © Copyright March 2024

How To.

