

Post & Rail Fencing

Fencing Installation Guide



Post & Rail Fencing

Stratco Post & Rail fencing is a traditional and cost effective form of fencing. Its simple design makes it the ideal choice for a DIY project. Galvanised posts and rails are combined with fence sheets that come in a range of different profiles, topped off with optional fence capping. Post & Rail Fencing is available in fence heights of 900mm, 1200mm, 1500mm and 1800mm. Its simple design makes it an ideal choice for use on sloping sites and uneven ground.

Pick from a huge range of fencing colours and choose from a wide range of fence sheet profiles including CGI corrugated, CGI Mini, Maxiclad®, Smartspar®, Superdek® and Wavelok®.

Before You Start

Before beginning your fencing project, ensure you have all the correct components and tools needed to finish the job. To ensure a neat finish, any gates should be installed before beginning work on the rest of the fence.

Tools and Hardware Required

- Concrete
- Hack-saw
- Plumb Line
- Spirit Level
- String Line
- Tape Measure
- Tin Snips
- Post Hole Digger
- Rivet Gun
- Drill and Hex-head Adaptor



Post & Rail Fencing Installation Guide

Designing Your Fence

Accurately determine the position of the fence (in some cases a surveyor may be required) and mark the position using a temporary string line. Using the spacing information provided in the table below, mark the position of the posts. If you are unsure of the wind speed for your area, refer to the brochure titled 'Determining Wind Speed'. You may decide to taper the free end of a fence to help it withstand strong winds (figure 5.0). Alternatively the post spacings at a free end are to be reduced as indicated in the table below.

Table 1.0 - Fence Post Spacings Per Wind Speed

Wind Speed	Internal	Free End	Tapered End
W28	3000	1500	3000
W33	2250	1200	2250
W41	1500	800	1500

Figures are based on a maximum fence height of 1800mm. The free end spacings are required for a distance equal to twice the fence height, if the end is not tapered.

GATE POST OPENINGS - Single 865mm - Double 3280mm

These are recommended measurements. Check the gate widths before concreting the posts.

Once marked, the post holes can be dug. The use of a manual or mechanical auger is recommended, especially for harder clay soils. The footings should be a minimum of 700mm deep by 200mm in diameter for a firm natural sandy clay. For variable soil conditions these dimensions should be increased if considered necessary. The last three holes near a free end and for posts supporting a gate will need to be 100mm deeper than the standard depth.

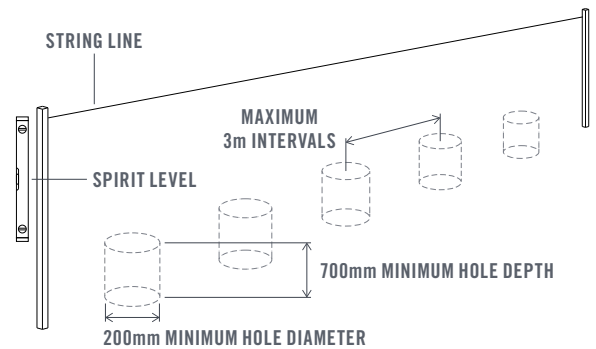

FIGURE 1.0

Gate and Footing Installation

Please Note: To prevent possible damage to the gate in high wind weather, the drop bolt must be installed on the gate.

Installing the gates

All gates should be installed before the remainder of the fence is constructed. The gate must be fixed to the SHS gate posts before placing the posts in the ground. Fix the hinges to the gate using the screws provided. Two hinges are required per side. Fix the hinges to the SHS post, making sure the top of the post is flush with the top of the gate. Place the assembled gate and posts into the pre-dug holes. Gate posts should be offset 25mm from the fence posts. The fence rails run into the gate post with the outside face of the rail sitting flush with the outside face of the gate post. To allow for deflection under the weight of the fence, the centre of the gate must be chocked up with wooden blocks, so the gate posts can be positioned between 8mm and 14mm off vertical. Use a plumb line to check this measurement, then concrete into place, as outlined in 'Preparing the footings'.

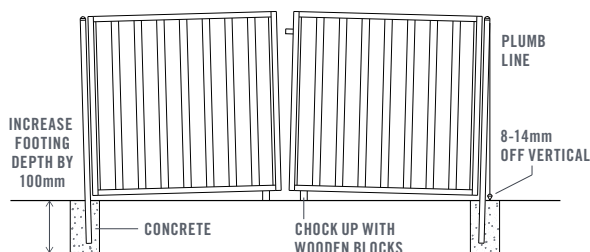

FIGURE 2.0

Preparing the footings

If the fence has a tapered end, cut any posts involved in the taper first (refer to 'Tapered End'). Position and prop the SHS posts into their pre-dug holes, using the string line and spirit level to keep them square and plumb. Prepare the Stratco concrete mix as per the details on the bag. Posts should be embedded at least 500mm into the concrete. Fill the hole with approximately 150mm of concrete. Using a shovel or a pole, agitate the concrete to remove any air pockets. Add a further 150mm and agitate again. This process should be repeated until the hole is full. The top of the footing will need to be smoothed with a trowel to ensure the surface slopes away from the post. No load should be applied to the footing for at least 48 hours. Maximum concrete strength may not occur for up to 28 days, so care should be taken not to allow excessive force on the fence during this time.

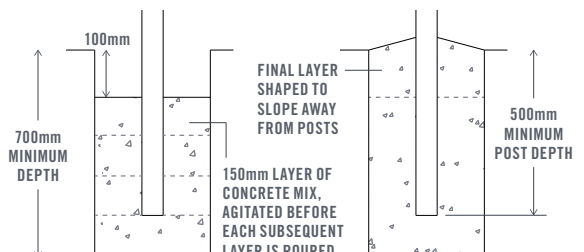
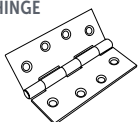

FIGURE 2.1

Gate Components And Accessories - Components are supplied with fixings.

BUTT HINGE



DROP BOLT

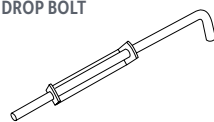

STRIKER PLATE



GATE LATCH

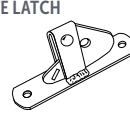

GATE LATCH HANDLE



PAD BOLT

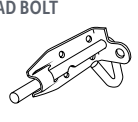

Rail & Sheet Installation

The rails must be attached to the pre-installed posts. Use a string line to position the rails. The rails are fixed to the posts by fitting a saddle over the rail and fixing it to each post with two self-drilling screws (figure 3.0). Fit the post caps over the end of the posts and knock into place. If you want to paint the posts and rails, do this before attaching the sheets.

When positioning the sheets, it will look best if the sheet overlap is arranged to face away from the most commonly viewed angle. The top of the sheets should sit

250mm higher than the top of the posts. Ensure the top of the sheets are level by using a string line. Sheets are to be fixed to the rails with self-drilling screws, please refer to figure 3.1 for the number of screws per sheet according to the sheet profile. The screws are fixed through the sheet along the centre of the rail. To keep the screws in line with each other, use a string line along the fence (see figure 6.0), or use a measuring stick that shows the distance from the edge of the sheet to the centre of the rail.

Fence Components and Accessories

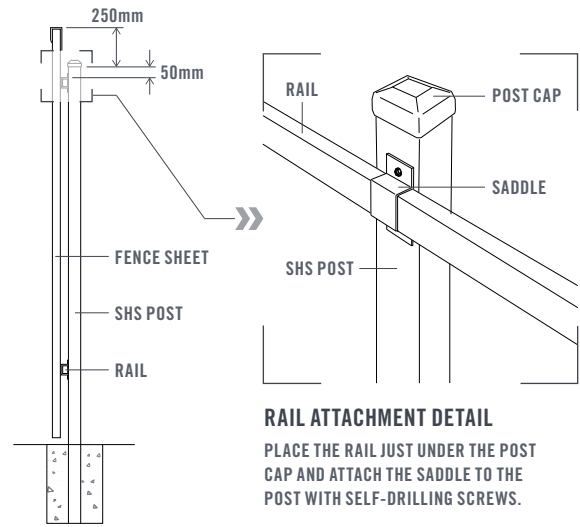
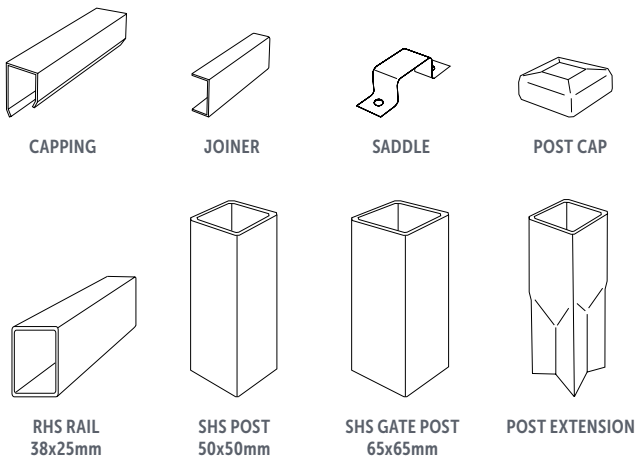
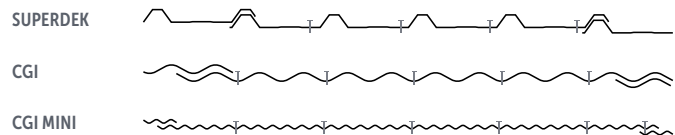
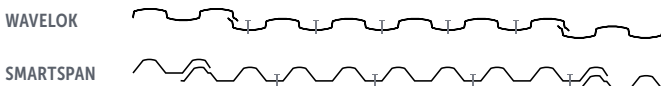

FIGURE 3.0

Overlap Details For Each Sheeting Profile



The best visual result will be obtained when the sheet overlap is arranged to face away from the most commonly viewed angle.

FIGURE 3.1

Horizontal Fencing

Begin by following the previous sections on how to layout your fence and concrete the posts. From the centre of each post to the next, they should be no greater than 2400mm apart. Horizontal fencing does not require any rails as the fence sheets are fixed directly to the posts. Only Superdek and Smartspan profile sheets are used.

For strength, the fence sheets should be long enough to cover three or more post spacings and should overlap by 150mm. Position the sheets, with the overlap at the bottom. The top of the fence sheets should sit flush with the top of the fence posts. Install the top sheets first using 10x16mm self-drilling screws, but temporarily leave the bottom fixing to allow the lower sheet to fit under. Ensure that you lap the bottom sheet under the top sheet for a neat appearance. Continue fixing down the post.

Where the sheets lap, fix the lapping with 3mm rivets or 10x16mm self-drilling screws. Complete the installation by installing the capping as outlined on the back page.

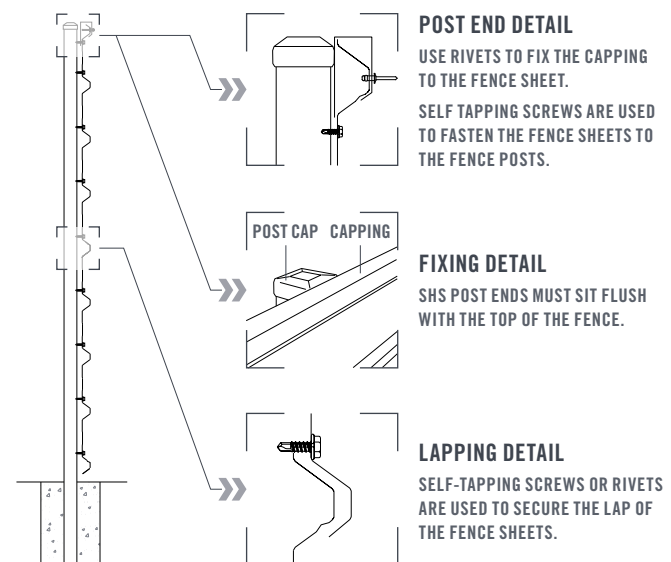

FIGURE 4.0

Tapered End

If you are tapering the free end of a fence, the taper must cover a length equal to twice the height of the fence. The end height shall be a maximum of two thirds the height of the rest of the fence. Cut the posts to the required height and attach the rails to the posts

following the taper. The fence sheets on the tapered end will need to be marked and cut to the appropriate height. Avoid using an angle grinder to cut the sheets as the swarf may stain the painted surface.

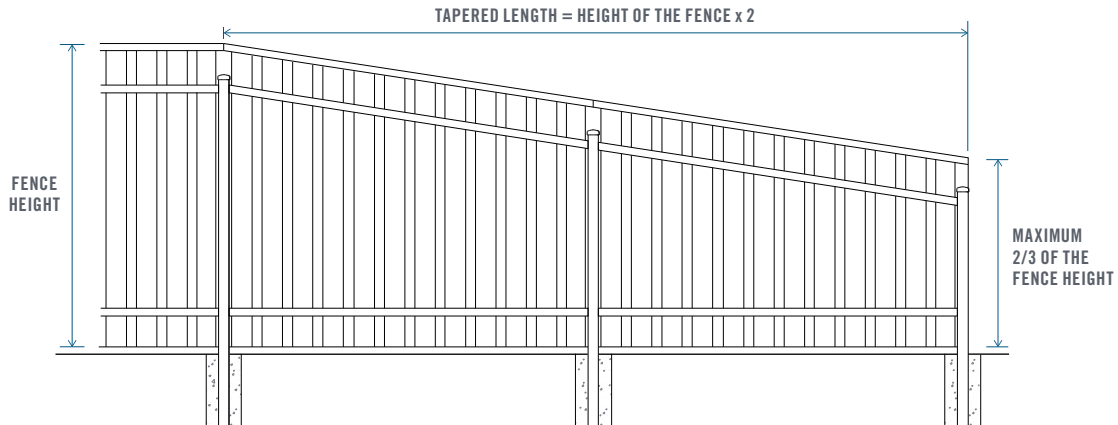

FIGURE 5.0

Capping Installation

Fence capping is placed over the top edge of the fence sheet with the long side of the capping facing the post and rail side of the fence. The capping is slightly tapered to allow for overlapping. To fix the capping,

drill a hole at each end where the crest of the fence sheet meets the inside of the capping. Use either a rivet or a self-drilling screw to fix the capping and the fence sheet together.

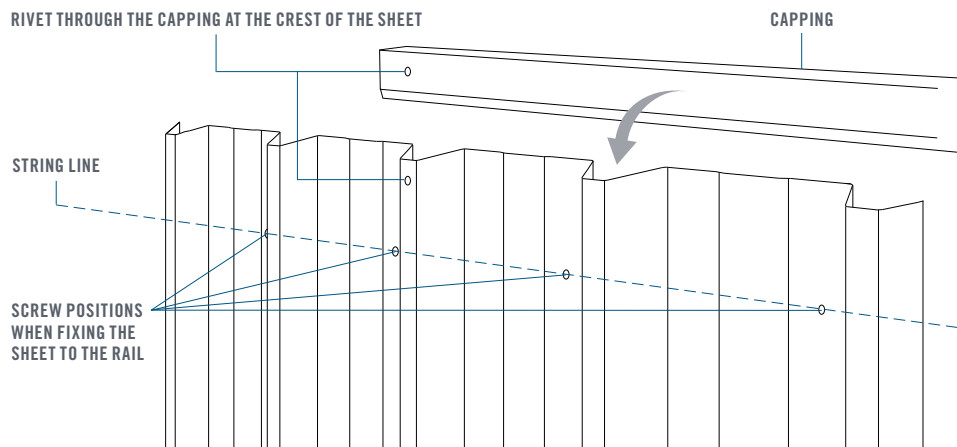

FIGURE 6.0



« SCAN THIS QR CODE TO FIND A STRATCO NEAR YOU

1300 155 155
stratco.com.au

All brands and logos/images accompanied by © or ™ are trade marks of Stratco (Australia) Pty Limited. © Copyright January 2012

How To.



MAINTENANCE Fencing may not be suitable within 1000 metres of a marine environment or in severe industrial or corrosive environments. It is important that dirt, compost, paving sand or other materials are not placed against any Stratco steel sheeting. Zinc/Al based materials must not be used in any of these circumstances, and in particular concrete should not be poured against Zinc/Al based materials. For more information refer to the 'Selection, Use and Maintenance of Stratco Steel Products' Brochure.