

# How To.

## INSTALLATION GUIDE



### COUNCIL APPROVAL

It is important to contact your local council before building your Stratco Gable Roof Shed. You will have already received details for your proposed structure to include for council approval application (including: Stratco Design Specifications, Site Plans, Elevations, and where required Slab layouts or Engineering Letter). It is important to draw a plan view of your Shed (showing distances from boundaries and existing buildings) and include this detail as part of your submission for council approval. This view can be copied from the plan view found in your Stratco Design Quote, Specifications & Elevations document.

### BEFORE STARTING

Confirm that all of the material listed on the delivery document has been supplied. Carefully read these instructions to ensure you are familiar with all steps involved. Ensure you have the correct tools and equipment for the job as listed on this page. **Note: Always check the documentation you receive with your shed for specific installation instructions as they may differ in some scenarios.**

### TOOLS REQUIRED

Safety Glasses 	Gloves 	Hearing Protection 	Step Ladder 	Tape Measure 	Spirit Level 	String Line 	Rubber Mallet 
Grips 	Cutting Tools Hacksaw  Angle Grinder 	Tin Snips 	Power Drill 	Hex Head Adapter 	Phillips Head Adapter 	Drill Bits (Assorted) 	
Locking Pliers 	Rivet Gun 	Socket Set 	Adjustable & Combination Spanner 	Spray Lubricant 	Adhesive Tape 	Clamps 	Caulking Gun & Silicon 

# STRATCO SHEDS & GARAGES

DOMESTIC INSTALLATION GUIDE

## CONTENTS

### BASIC INFORMATION

1. Components
2. Framework - Typical Connections
3. Typical Flashing Details

### SITE PREP & FOOTINGS

4. Site Preparation
5. Fixing Into Concrete (Fixed-In-Ground)
6. Pinning Onto Concrete (Pinned-On Concrete Slab/Piers)
7. Slab Preparation

### GENERAL FRAME & CLADDING INSTALL

8. Preparing the Frame
9. Bracing
10. Constructing the Walls
11. Building the Frame - Gable Roof Sheds
12. Building the Frame - Skillion Roof Sheds
13. End Wall Installation
14. Hiland Tray Wall Cladding
15. External Gutter & Downpipe Installation
16. Box Gutter & Downpipe Installation
17. Roof Cladding Installation

### OPENING DETAILS

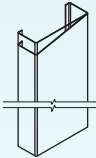
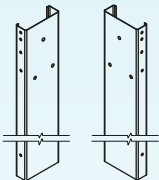
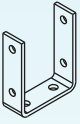
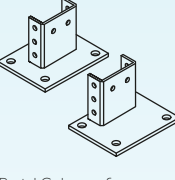
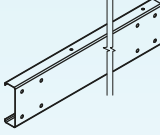
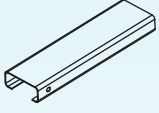
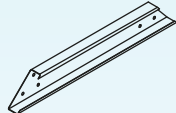
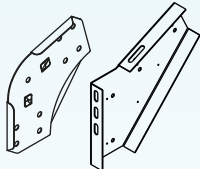
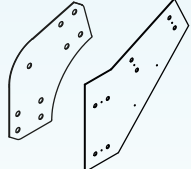
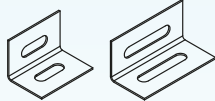
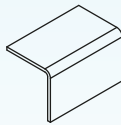
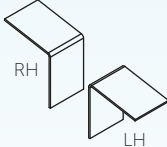
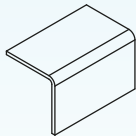
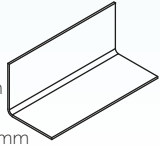
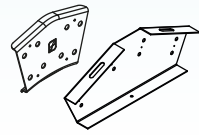
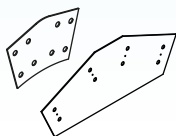
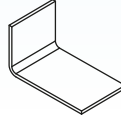
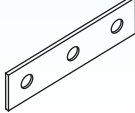
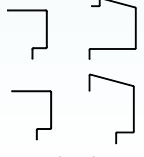
18. Personal Access Door
19. Windows
20. Clear Opening - Side Wall
21. Roller Door Installation - Side Wall
22. Sliding Door Installation - Side Wall
23. Roller Door Installation - End Wall
24. Sliding Door Installation - End Wall

### FINISHING TOUCHES

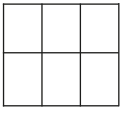

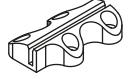

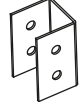
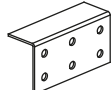

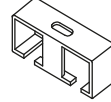



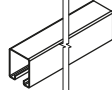
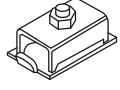
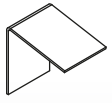
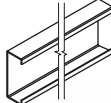

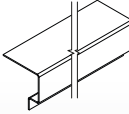
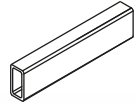
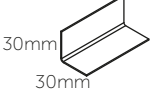
25. Flashings
26. Maintenance

# 1. COMPONENTS

## FRAME

<p>Internal Column</p>  <p>Mitred on site</p>	<p>Portal Columns</p> 	<p>Stirrup</p>  <p>Portal Columns, Internal Columns, Gable End Columns</p>	<p>Spigot</p>  <p>Portal Columns &amp; Skillion Columns</p>	<p>Rafter</p> 	<p>Wall Girt, Roof Purlin &amp; Bridging</p>  <p>75 C-Section</p>	<p>Knee Brace</p>  <p>150 C-Section</p>
<p>Eaves Bracket</p>  <p>15, 22, 25, 27.5, 30, 40 &amp; 45 degree pitches available.</p>	<p>Strengthening Washer Plate</p> 	<p>Angle Connector</p>  <p>100mm 150mm</p>	<p>Girt Bracket</p>  <p>40x40x66mm</p>	<p>Apex Bracket</p>  <p>RH LH</p>	<p>Header Beam Bracket</p>  <p>35x35x75mm</p>	
<p>Raking Angle</p>  <p>50mm 50mm</p>	<p>Ridge Connection</p> <p>Ridge Bracket</p>  <p>15, 22, 25, 27.5, 30, 40 &amp; 45 degree pitches available.</p>	<p>Strengthening Washer Plate</p> 	<p>75mm Bridging Bracket</p> 	<p>Girt / Purlin Joining Plate</p> 	<p>Garaport Flashings</p>  <p>Standard (Left) Hiland Tray (Right)</p>	

## SLIDING DOOR

<p>Sliding Door Frame</p> 	<p>Sliding Door Frame Fixings</p> <p>Carriage Wheels</p> 	<p>Tracking Pad</p> 	<p>Sliding Door Header Beam Bracketry</p> <p>50mm Header Beam Bracket</p> 	<p>Gutter Side Header Beam Bracket</p> 	<p>Gutter Side Header Beam Bracket Joiner</p> 
<p>Sliding Door Track Bracketry</p> <p>Sidefix Support</p>  <p>Single Bracket</p>	<p>Track Supports</p> <p>Double Track Bracket</p> 	<p>Single Track Bracket</p> 	<p>M10x20 Sidefix Support Bolt &amp; Washer</p>  <p>Track Support Bolt</p> 	<p>Track</p> 	<p>Track Stop</p> 
<p>Apex Bracket</p> 	<p>Sliding Door Header Beam</p>  <p>150 C-Section</p>	<p>Filler Column (When Required)</p> 	<p>End Wall Single Sliding Door Spacer Flashing</p> 	<p>Sliding Door Frame Joiner Spigot</p> 	<p>Sliding Door Frame Angle Track</p>  <p>30mm 30mm</p>

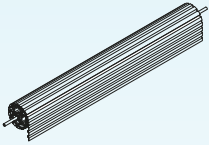
# DOMESTIC SHED INSTALLATION GUIDE

## 1. COMPONENTS

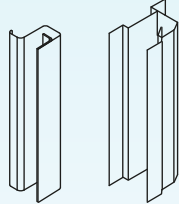
### ROLLER DOOR

Roller Door Components

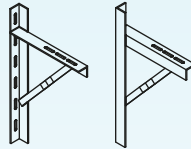
Curtain



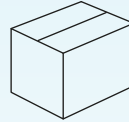
Roller Door Guides



Roller Door Support Brackets

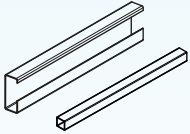


Accessories Box

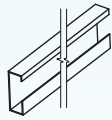


Roller Door - Gable End

Header Beam  
100mm C-Section  
50mm/65mm SHS



Connector Sleeve

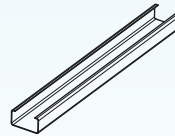


Door Jamb  
20015  
C-Section



Roller Door - Gutter Side

Header Beam  
75mm C-Section

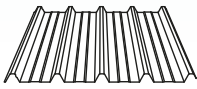


Door Jamb  
20015  
C-Section



### SHEETS

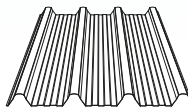
Stratco  
Superdek



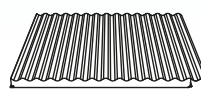
CGI



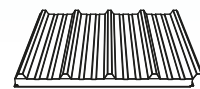
Prodek Sheet



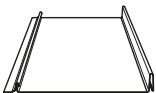
Cooldek CGI



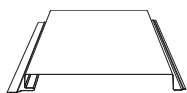
Cooldek Classic



Hiland Tray Nailstrip,  
265mm Cover  
38mm Rib Height

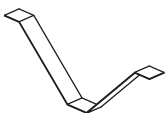


Hiland Interlock  
195mm Cover &  
295mm Cover



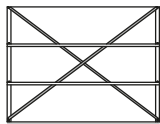
### BRACING

Fly  
Brace



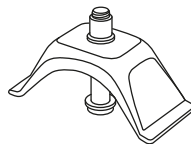
G300 Strap

Strap  
Bracing



G300 Strap

Strap Brace  
Tensioner

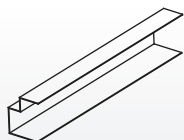


### PERSONAL ACCESS (PA) DOOR

PA Door Frame



PA Door Mullion



PA Door 45mm  
Angle Bracket

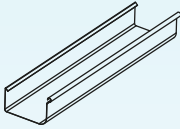
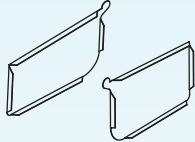
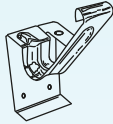
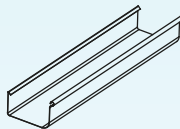
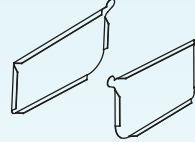
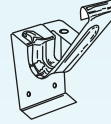
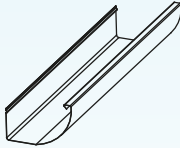

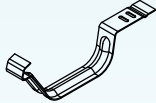

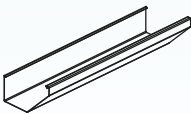
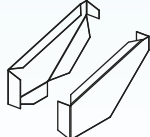

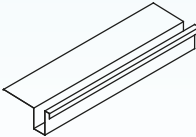

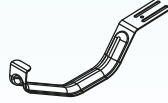
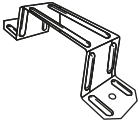
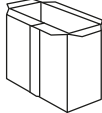



Door Handle +  
Tongue





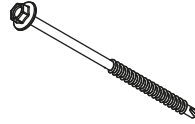
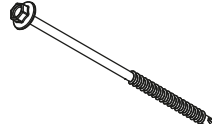
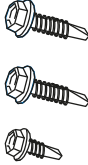

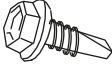
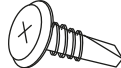
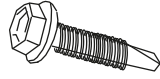





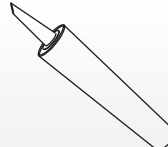



# 1. COMPONENTS

## GUTTERS

125 Quad Gutter - (QLD)			115 Quad Gutter - (SA, NSW and VIC)		
Gutter 	Stop Ends 	Gutter Bracket 	Gutter 	Stop Ends 	Gutter Bracket 
Quarter Round Gutter - (WA)					
Gutter 	Stop Ends 	Gutter Bracket 	P-Clip 		
Edge Gutter - (National)					
160 Gutter 	Stop Ends 	Gutter Strap 	Box Gutter 	Box Gutter Stop Ends 	Gutter Strap 
Downpipe Straps 	Downpipe Outlet 	Downpipe 			

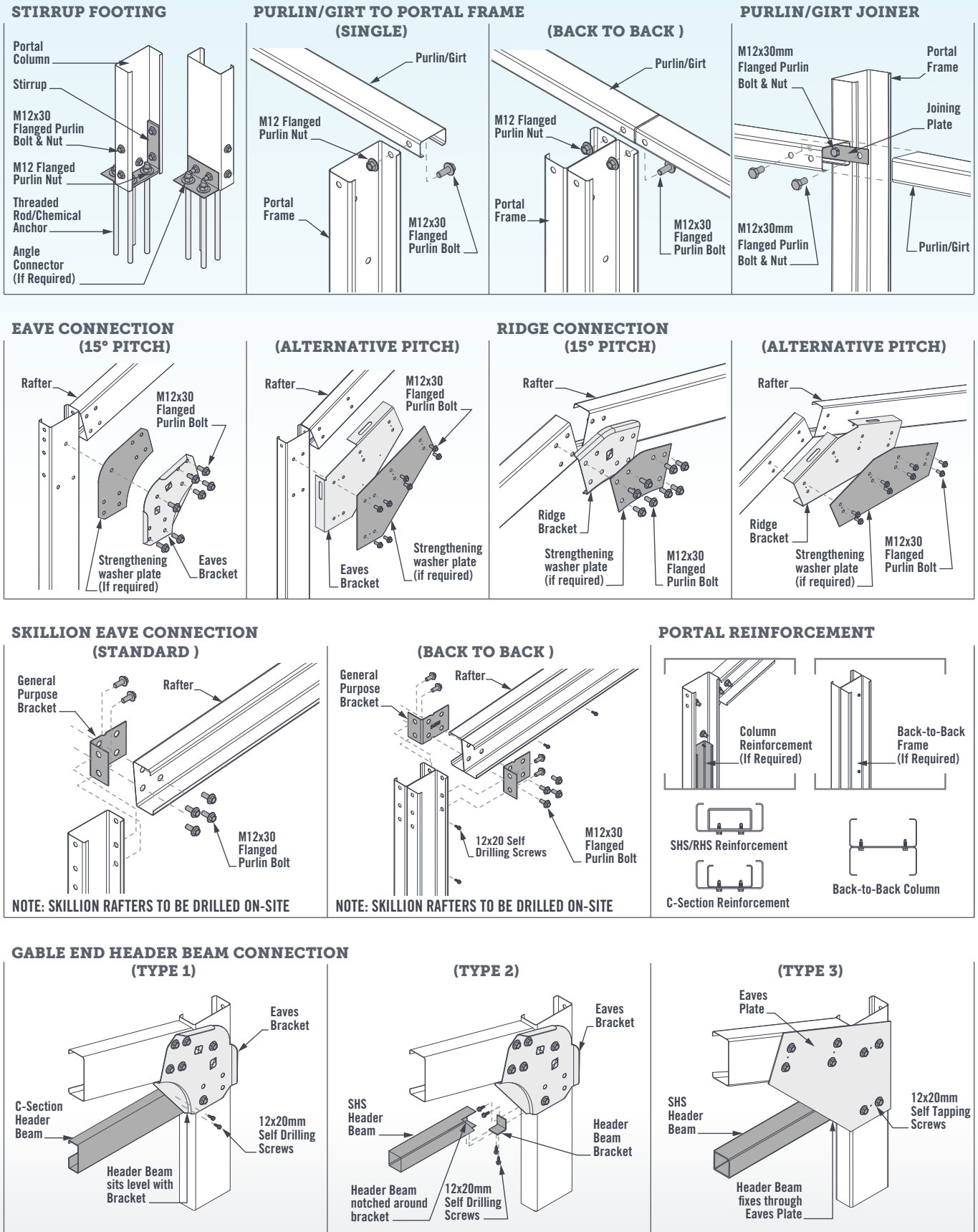
## FIXINGS

Bolts			Self Drilling Screws		
Purlin / Girt  M12x30mm Grade 8.8 (High Tensile) Flanged Purlin Bolts	Single Sliding Door  M8x75mm Hex Head or M8x90mm Hex Head	Sliding Door Gutter Side Header Beam  M12x30mm Fascia Bolts	3.2mm Rivet 	Cooldek CGI  14x110	Cooldek Classic  14x125
Self Drilling Screws					
Standard 14x20 12x20 10x16 	Roof CGI  12x35 OR M6x50mm Timber/Steel	Wall Superdek®  10x16	Wafer Head  10x16	Series 500  12x38	Cyclonic Washer Plate (Cooldek Roof)  To suit CGI and Superdek
On Concrete (Pinned)					
Chemical Anchor Capsule  Type A, C, G	M12 Chemical Anchor Stud, Nut & Washer  Type A, C, G	Nuts & Washers M12 M16 M20  Type B, D, E, F, H, I	Threaded Rod M12 M16 M20  Type B, D, E, F, H, I	Concrete Anchor Adhesive  Type B, D, E, F, H, I	M8 Masonry Anchor  Type B, D, E, F, H, I

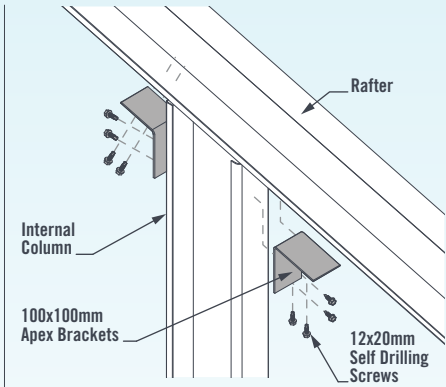
## 2. FRAMEWORK - TYPICAL CONNECTIONS

Note: All Flange Purlin Bolts must be secured to an appropriate level of tightness (**snug tight**), and care must be taken to avoid under or over-tightening.

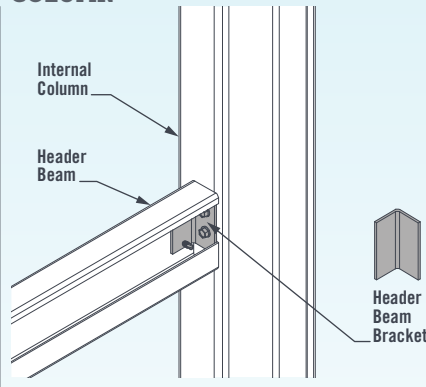
Snug tight can be defined as 'the tightness attained by a few impacts of an impact wrench or by the full effort of a person using a standard podger spanner'. Please refer to AS/NZS 5131:2016 for further details if required.



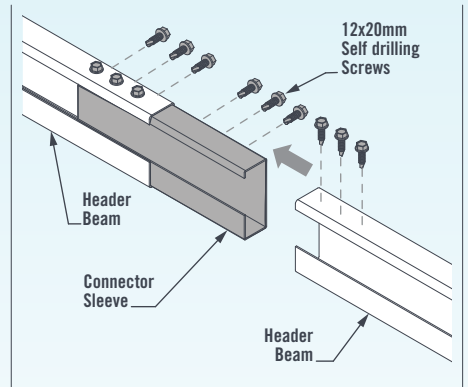
**INTERNAL COLUMN TO RAFTER**



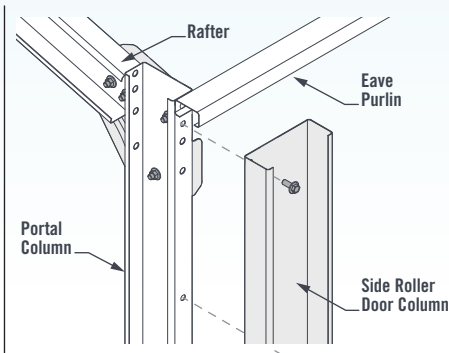
**HEADER BEAM TO INTERNAL COLUMN**



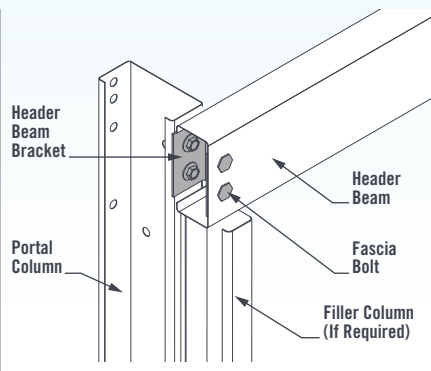
**HEADER BEAM CONNECTOR SLEEVE**



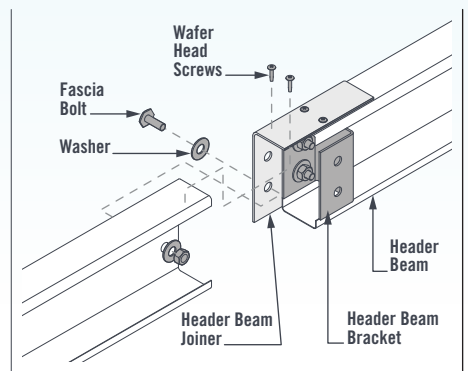
**GUTTER SIDE ROLLER DOOR COLUMN**



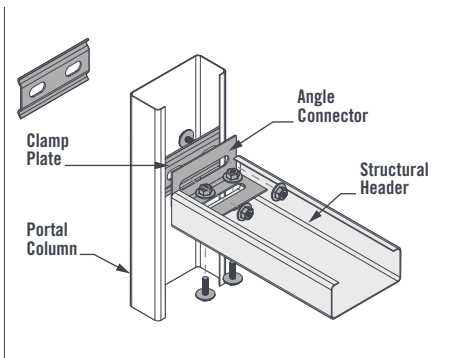
**GUTTER SIDE HEADER BEAM**



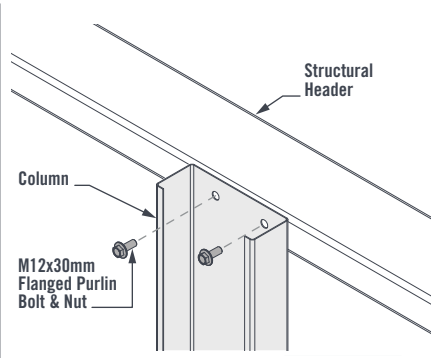
**GUTTER SIDE HEADER BEAM JOINER**



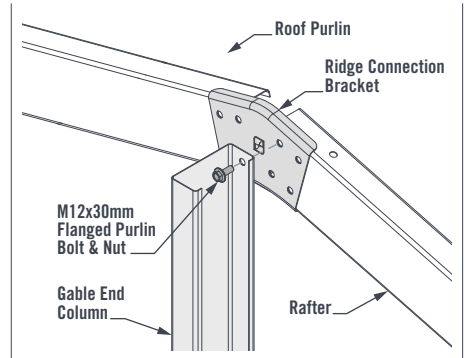
**GLASS SLIDING DOOR HEADER BEAM TO PORTAL COLUMN**



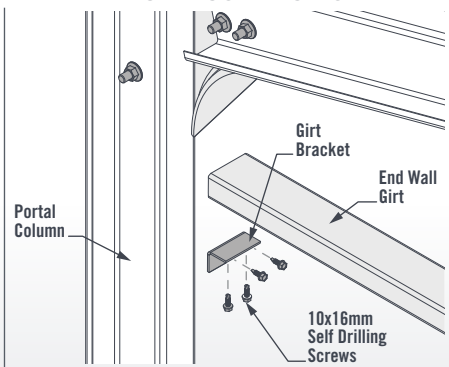
**GLASS SLIDING DOOR COLUMN TO HEADER BEAM**



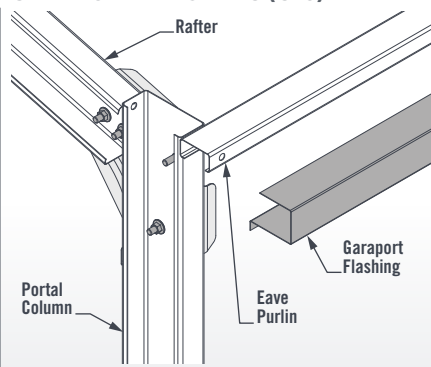
**END COLUMN TO RIDGE BRACKET**



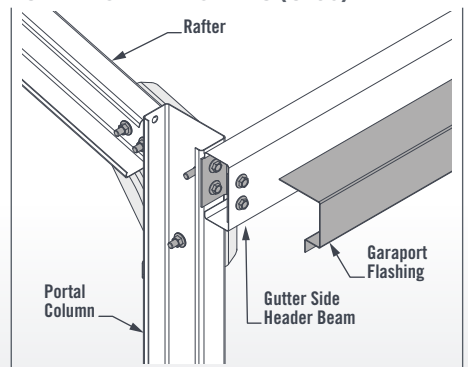
**END WALL GIRT CONNECTION**



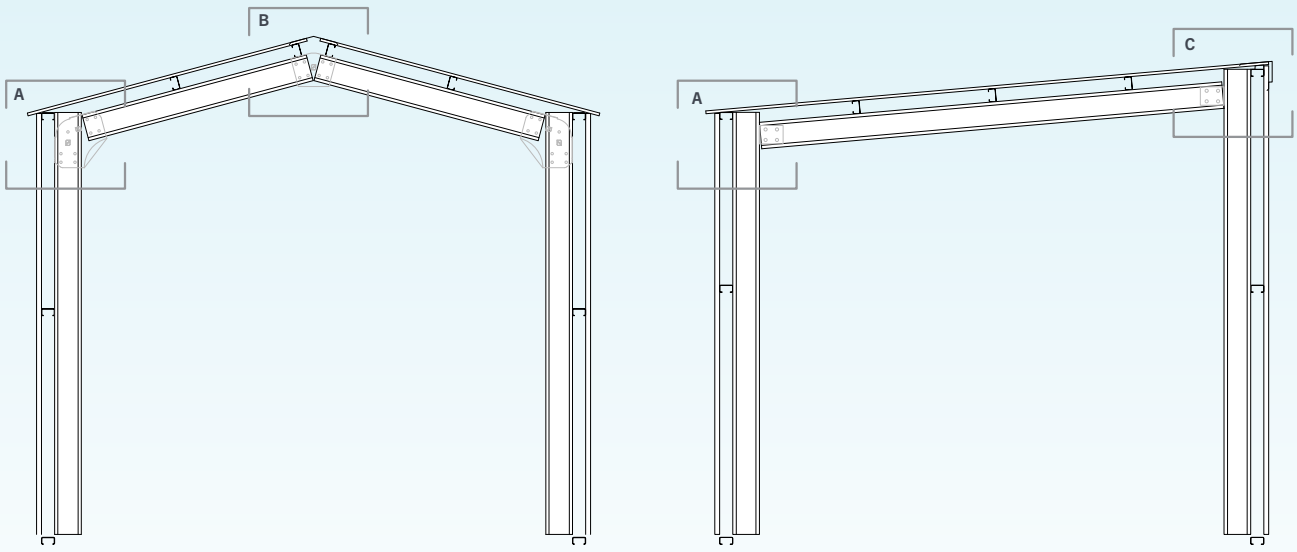
**GARAPORT FLASHING (C75)**



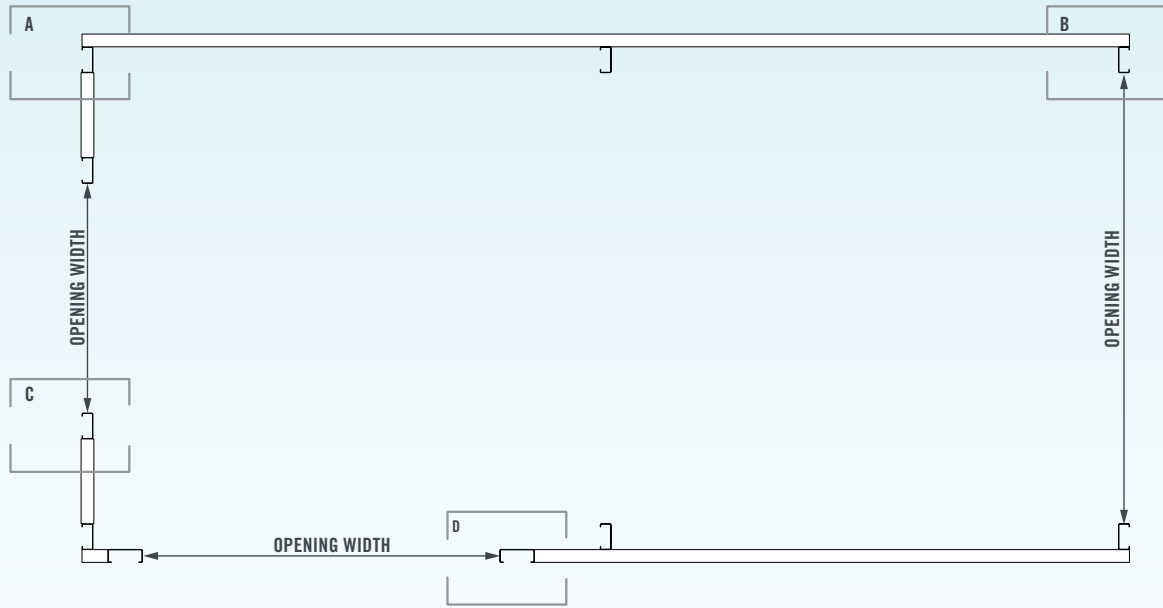
**GARAPORT FLASHING (C150)**



3. TYPICAL FLASHING DETAILS



		CGI SUPERDEK INTERLOCK	HILAND TRAY NAILSTRIP	COOLDEK
DETAIL A	GARAPORT FLASHING (C75)			
	GARAPORT FLASHING (C150)			
DETAIL A	LOW SIDE EAVE (C75)			
	LOW SIDE EAVE (C150)			
DETAIL B	GABLE RIDGE			
DETAIL C	SKILLION HIGH SIDE (C75)			
	SKILLION HIGH SIDE (C150)			



	<b>DETAIL A CORNER FLASHING</b>	<b>DETAIL B FRONT CORNER FLASHING</b>	<b>DETAIL C INTERNAL CORNER FLASHING</b>	<b>DETAIL D GUTTER SIDE INTERNAL CORNER FLASHING</b>
<b>SUPERDEK</b>				
<b>CGI</b>				
<b>HILAND TRAY</b>				
<b>INTERLOCK</b>				
<b>COOLDEK (CLASSIC)</b>				
<b>COOLDEK (CGI)</b>				

## 4. SITE PREPARATION

Determine the position of the shed. If the ground is uneven or sloped, ensure that the slope does not exceed more than 150mm.

If your shed is being pinned onto a concrete slab refer to Section 6.

Mark out the footing hole locations as specified in your Specs & Elevations document. Check that the corner to corner measurements are equal. The image below shows the typical orientation of the columns and the slab layout. . Note, always refer to job specific paperwork or engineering to confirm these dimensions.

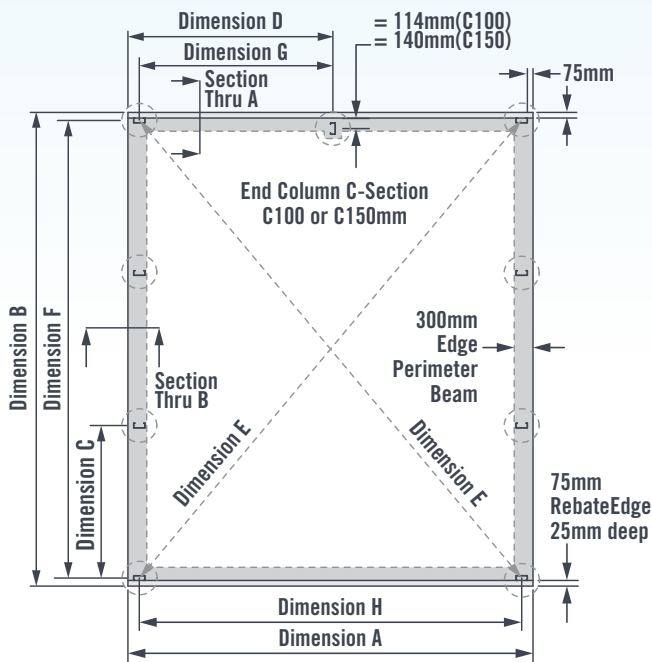


FIGURE 4.1

Note: where garaport bays, sliding doors or other openings are present, the slab may need additional width/length and/or rebate alterations. Please refer to Section 7 Slab Preparation for further information.

Mark out the slab dimensions as specified in your Specs & Elevations document, or the relevant span table/engineering letter and check that the corner to corner measurements are equal.

The outside edge of your slab shall be 75mm from the outside face of the columns.

If a rebate is required, ensure the top of the rebate begins in-line with the outside face of the columns.

Refer to the relevant Construction Footing Report for more information regarding the perimeter beam and other slab requirements.

## 5. FIXING INTO CONCRETE (FIXED IN GROUND)

Dig the column holes as specified in your Specs & Elevations document, or the relevant span table/engineering letter. If you are pouring a concrete slab, the slab must be a minimum of 100mm deep.

Use string line and a spirit level to ensure the holes are level with each other. Measure each hole depth to ensure the shed will stand level when the walls are placed in position.

Refer to shed specific documents and/or span tables to find the required pier size and column embedment for your shed. Fill the base of each hole with enough concrete to fill the difference between pier depth and column embedment. This will ease settlement and make up the distance between the base of the column and bottom of the hole. Before the concrete sets, score the top of the concrete and place a brick in the hole. Allow the concrete to set.

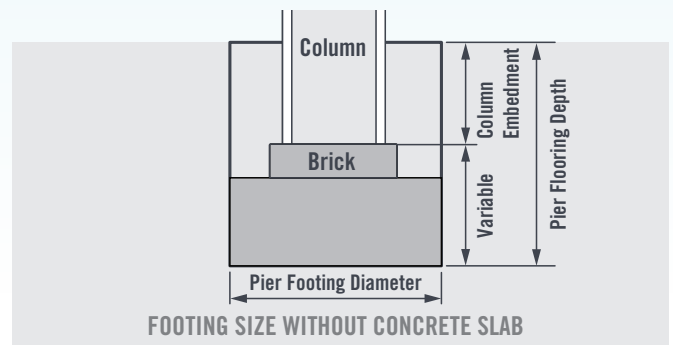


FIGURE 5.1

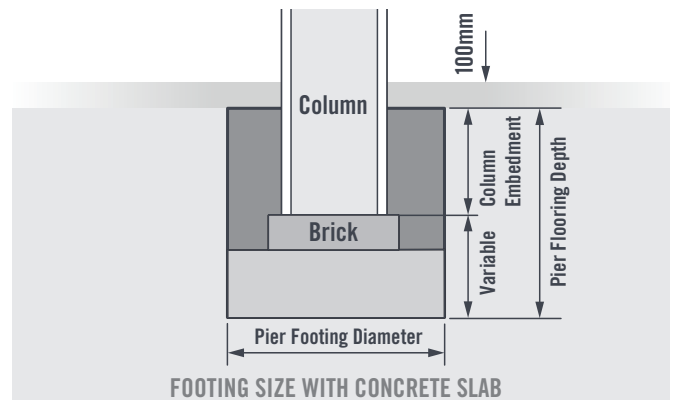


FIGURE 5.2

### COLUMN EMBEDMENT

Pier Footing Diameter (mm)	Column Embedment (mm)
< 600	Pier Depth - 100mm
600 - 1200	500mm
> 1200	Pier Depth - 500mm

FIGURE 5.3

The table above can be used as a guide for recommended embedments, but always refer to documents specific to your shed (including engineering if applicable) before starting install.

If you are installing a PA door, dig the door mullion footings at 300 wide x 300mm deep, see Section 18 PA Doors for more details. PA door mullion embedment to be 250mm.

## 6. PINNING ONTO CONCRETE (PINNED ON SLAB/PIERS)

For sheds that are Pinned-On-Concrete, footing type will be designated by span table or engineering letter, and will follow one of the 'footing types' listed below.

### FOOTING TYPE

A	8mm stirrup with 2x M12 chemical capsule anchor studs at 90mm embedment.
B	8mm stirrup with 2x M12 threaded rods with chemical injection to set anchor studs at 200mm embedment.
C & D	8mm stirrup + angle bracket with 4x M12 threaded rods with chemical injection anchor studs at 90mm (C) or 200mm (D) embedment.
E	8mm stirrup with 2x M16 threaded rods with chemical injection to set anchor studs at 250mm embedment.
F	8mm stirrup + angle bracket with 4x M16 threaded rods with chemical injection to set anchor studs at 250mm embedment.
G	8mm stirrup + angle bracket with 2x M12 threaded rods with chemical injection to set anchor studs at 90mm embedment.
H	8mm stirrup with 4x M12 threaded rods with chemical injection to set anchor studs at 200mm embedment.
I	8mm stirrup with 4x M12 threaded rods with chemical injection to set anchor studs at 250mm embedment.

Each stirrup is fixed to the column with four bolts and into the concrete perimeter beam with two threaded rods with chemical injection to set anchors. Threaded rods will need to be cut to the required length before embedding into the concrete. Threaded rod holes drilled into concrete shall be 14mm diameter.

**Note:** when a column is being used for an opening (roller door, glass sliding door, etc.) use Fascia Bolts for the stirrup on the side with the door.

### EXAMPLE FOOTING DETAIL

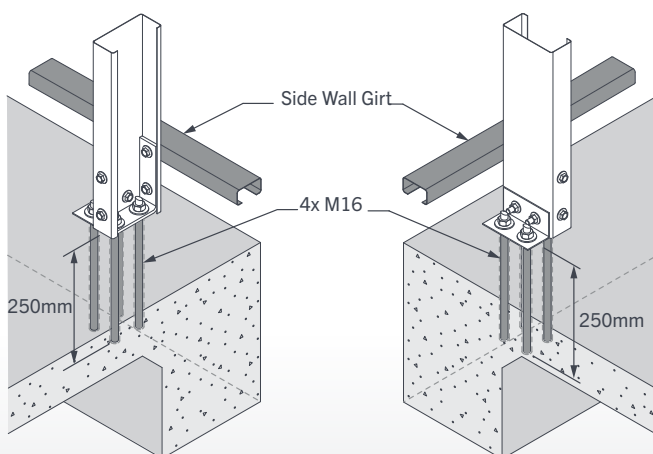


FIGURE 6.1

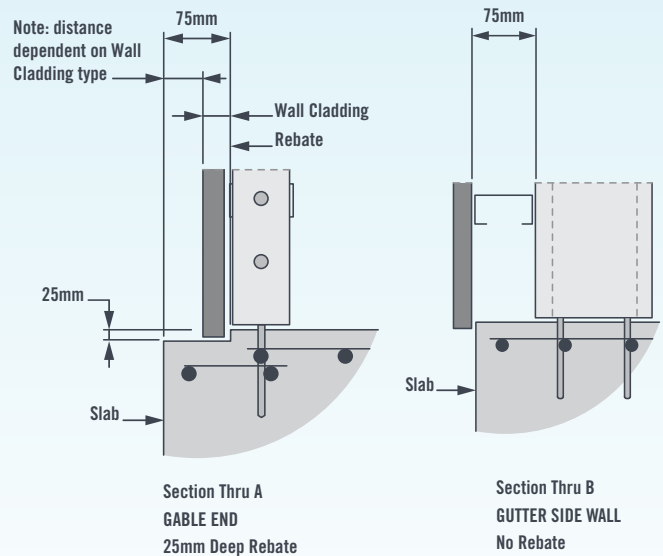


FIGURE 6.2

If using a toe mould flashing around the perimeter of the shed, consider how this fits with the edge of the slab. Recommended details are shown below for standard toe mould flashing profiles.

### RECOMMENDED SLAB / TOE MOLD EXAMPLE

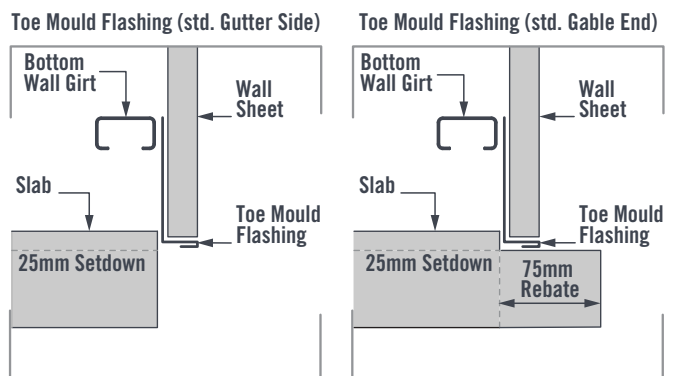


FIGURE 6.3

### OPTIONAL SLAB / TOE MOLD EXAMPLE

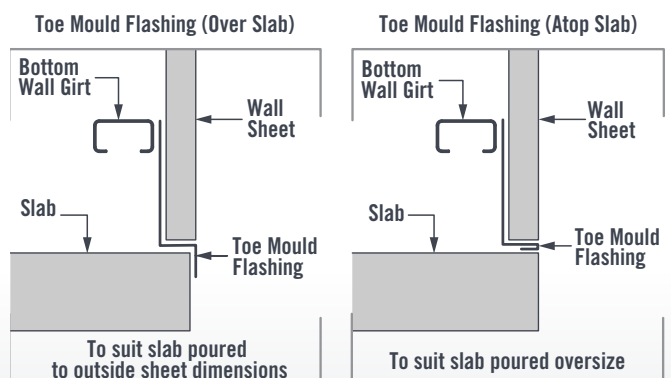


FIGURE 6.4

**TYPE A**

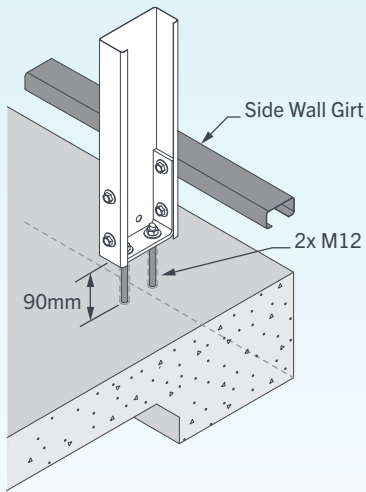


FIGURE 6.5

**TYPE B**

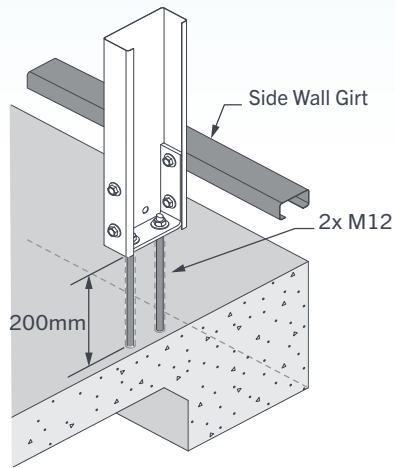


FIGURE 6.6

**TYPE E**

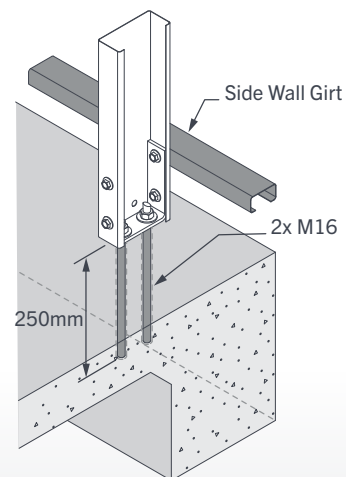


FIGURE 6.7

**TYPE C & D**

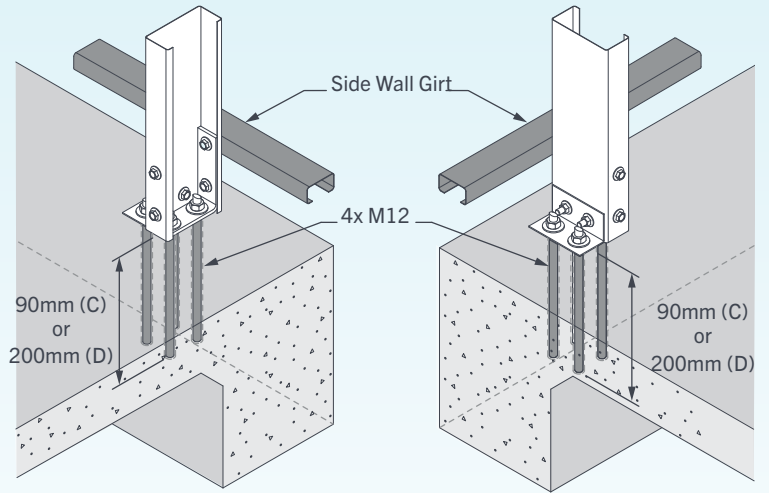


FIGURE 6.8

**TYPE F**

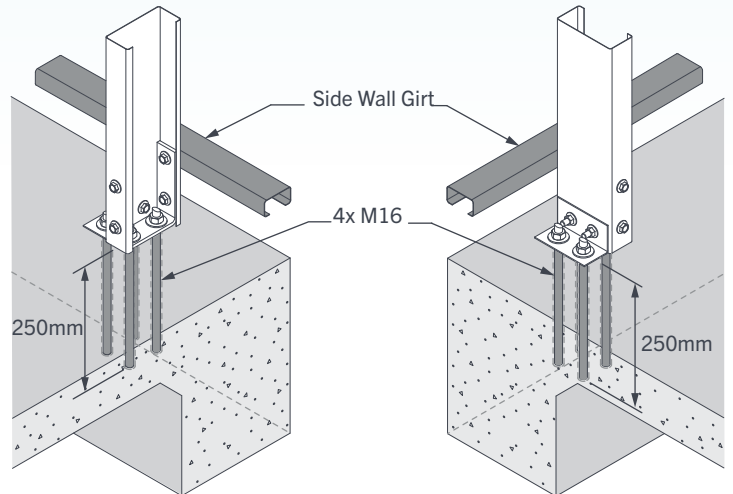


FIGURE 6.9

**TYPE G**

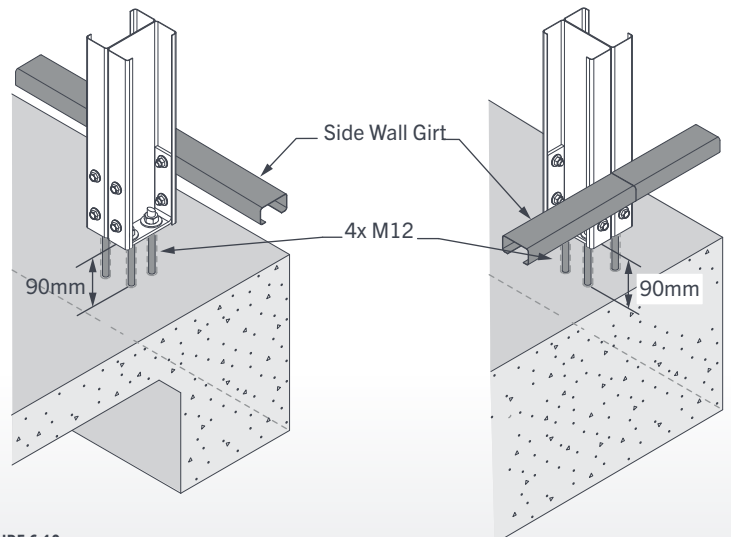


FIGURE 6.10

**TYPE H**

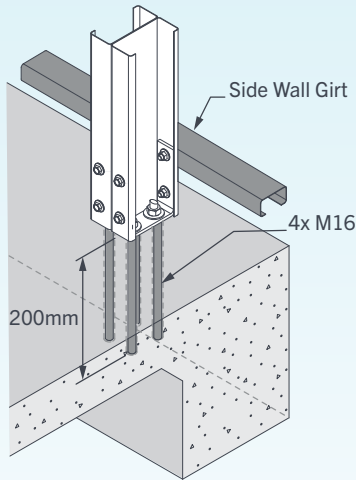


FIGURE 6.11

**TYPE I**

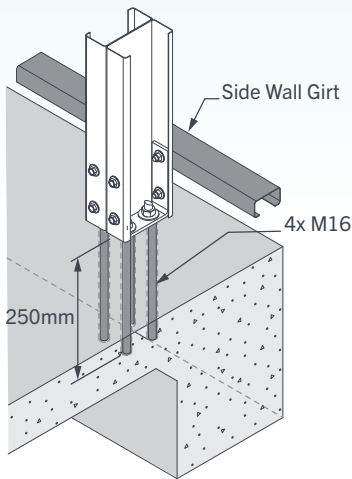


FIGURE 6.12

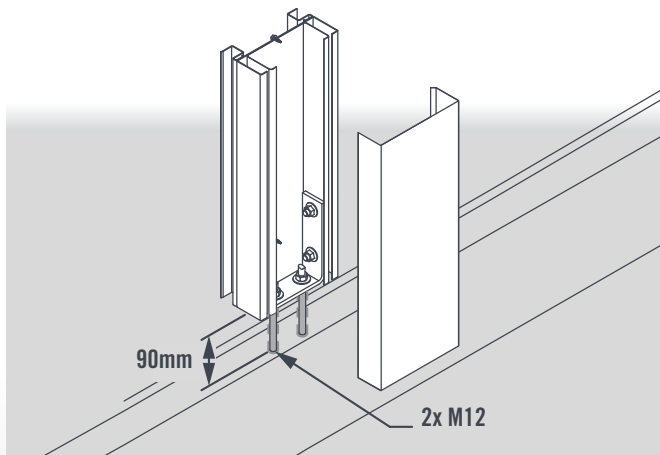


FIGURE 6.13

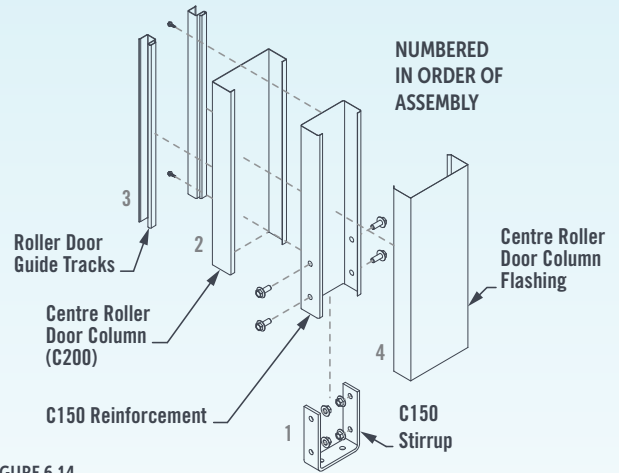


FIGURE 6.14

**END COLUMN & INTERNAL ROLLER DOOR COLUMN CONNECTION:**

The angle connector is fixed to the column with two bolts and into the concrete slab with two M12 chemical capsule anchors embedded a minimum of 90mm into the slab. Drilled holes shall be 14mm diameter with chemical injection required to set anchors.

Depending on the end column provided, C100 end columns require an angle connector with length 90mm. C150 end columns require an 8mm stirrup. For internal roller door columns, secure to slab using the Type A stirrup system previously detailed.

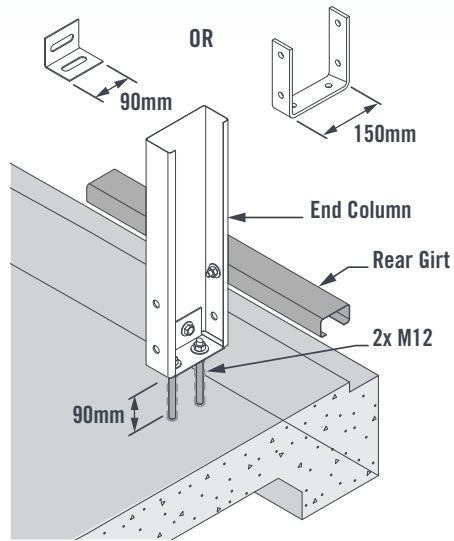


FIGURE 6.15

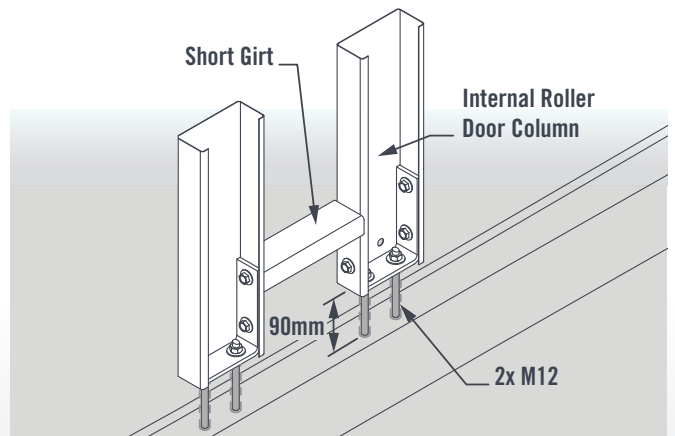


FIGURE 6.16

## FOOTINGS & SPIGOTS

For freestanding Garaports pinned onto concrete, spigot footing plates are generally required in place of stirrups. Refer to Stratco 15° Gable Roof Shed Span Tables (Book A) for more information regarding slab requirements.

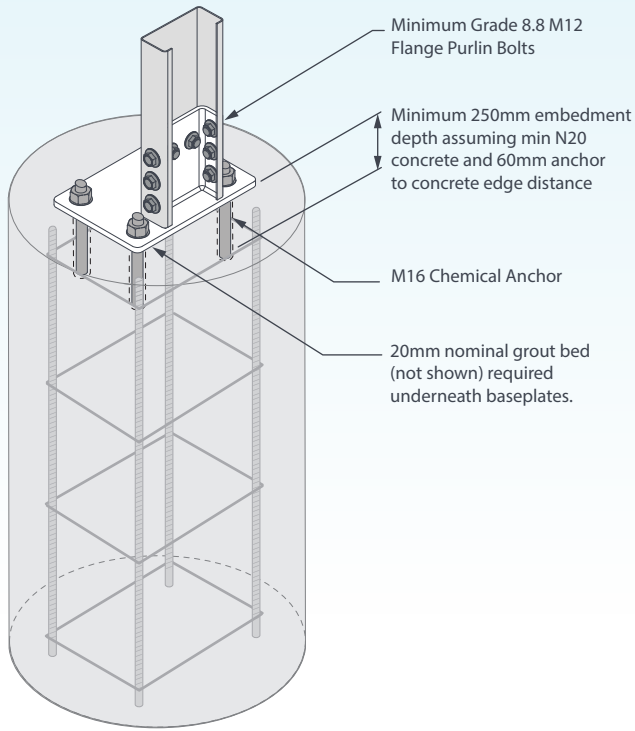


FIGURE 6.17 - END COLUMN WITHOUT SLAB

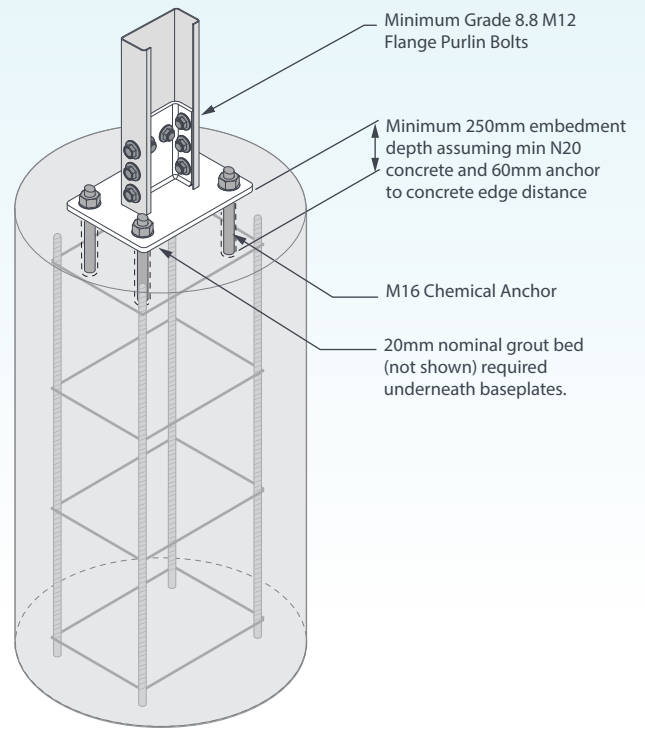


FIGURE 6.19 - INTERNAL COLUMN WITHOUT SLAB

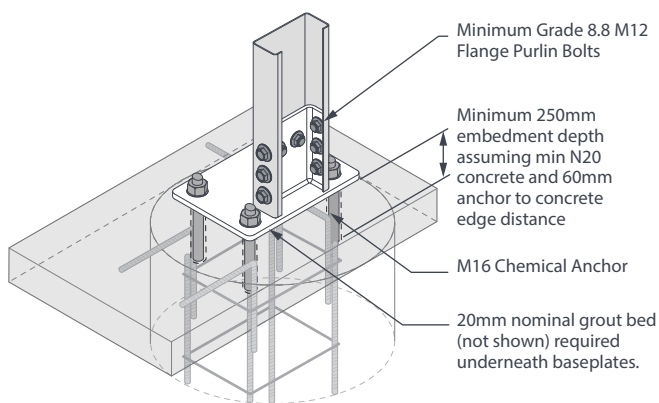


FIGURE 6.18 - END COLUMN WITH SLAB

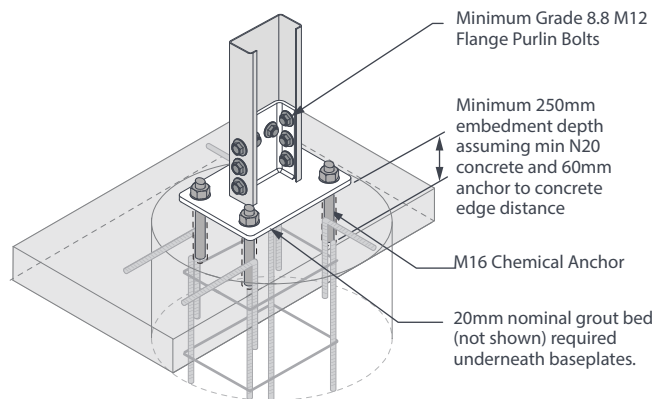


FIGURE 6.20 - INTERNAL COLUMN WITH SLAB

## 7. CONCRETE SLAB PREPARATION

Slab is to be minimum 100mm thickness, reinforced with SL72 fabric.

### NOTES:

1. Width of edge perimeter beam = 300mm.
2. Slab mesh SL72 for beams less than 350mm deep, SL82 for beams 350mm or deeper.
3. 8LTM200 trench mesh to be used where beams are deeper than 350mm, or where required due to soil conditions (determined by others).
4. Cover to reinforcement = 35mm, top and bottom, and to slab edge.
5. Concrete Grade N20.
6. Slabs suitable for Class A, S, M, M-D sites.

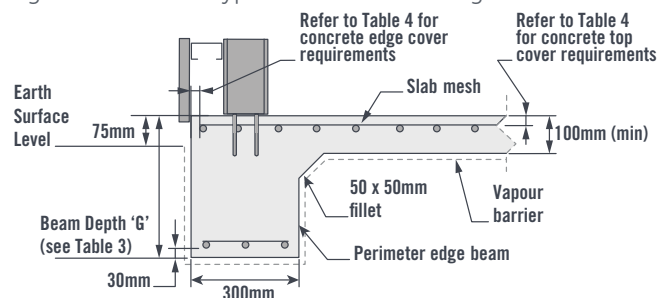
**Table 4 - Concrete Slab Requirements**

Slab Requirements	Interior (i.e. Inside Enclosed Garages)	Exposed (i.e. Under Garaport or Open Carports)		
	Concrete Exposure Classification			
	A1	A2	B1	B2
	Residential	Non-Residential	>=1km From Coastline	<1km From Coastline
Minimum Thickness (mm)	100	100	100	110
Concrete Grade (f'c) (MPa)	20	25	32	40
Concrete Cover (mm) (Top and Edge)	25	35	40	45

Shed slabs will require a concrete edge beam around the perimeter of the entire slab. The edge beam will generally be 300mm in width for standard sheds.

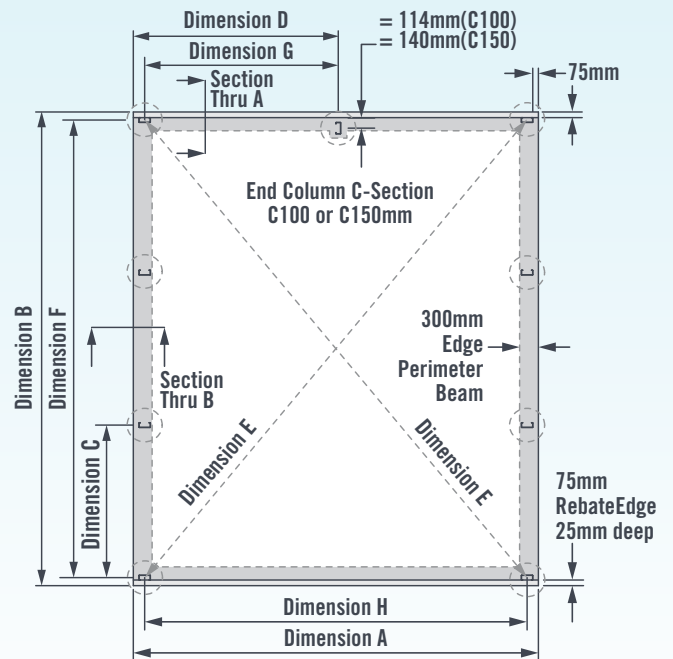
To determine edge beam depth, please contact Stratco for a copy of the relevant Construction Footing Report for your shed design. Refer to the corresponding notes for additional details including slab and edge beam reinforcing requirements.

Figure 7.1 shows a typical section through an edge beam and slab.

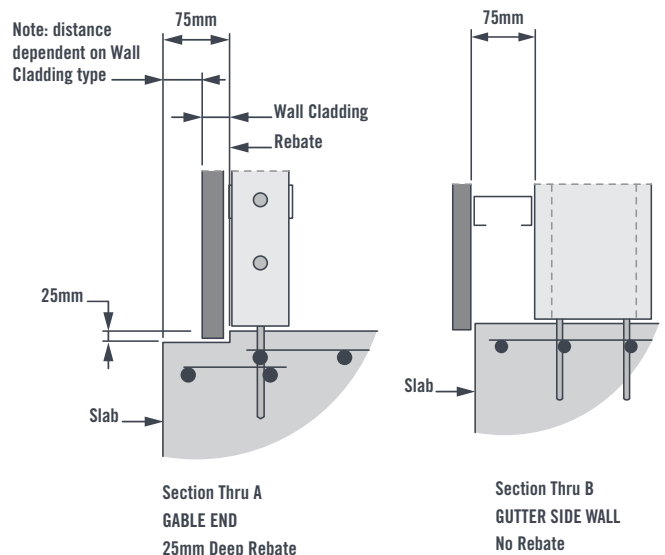


**FIGURE 7.1 - TYPICAL SECTION THROUGH EDGE PERIMETER BEAM**

Please refer to the specifications page (standard designs) or non-standard engineering letter (non-standard designs)



**FIGURE 7.2**



**FIGURE 7.3**

## GARAPORT - SLAB REBATES

For Garaport sheds with a concrete slab, it's recommended that the standard rebate on the end of the slab is extended to span the garaport bays. This 25mm rebate (setdown) will provide additional weatherproofing for the enclosed bay(s).

The images on this page provide an example for slab details, however your slab will vary depending on bay spacing, wall cladding locations, openings, etc.

If unsure of slab rebates, please contact Stratco for further information specific to your design of shed.

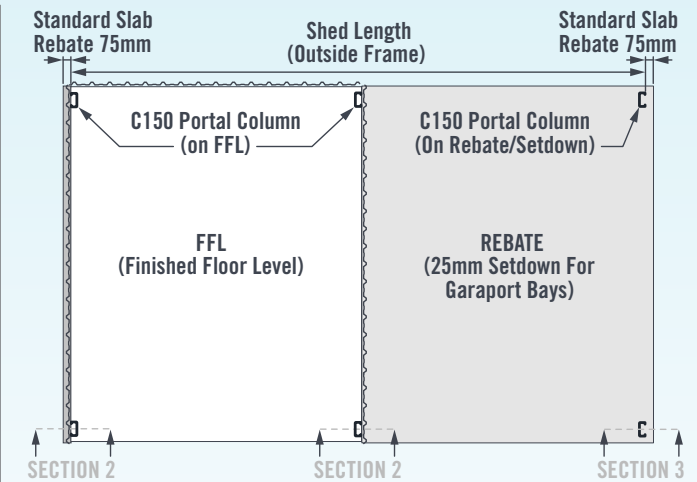


FIGURE 7.4

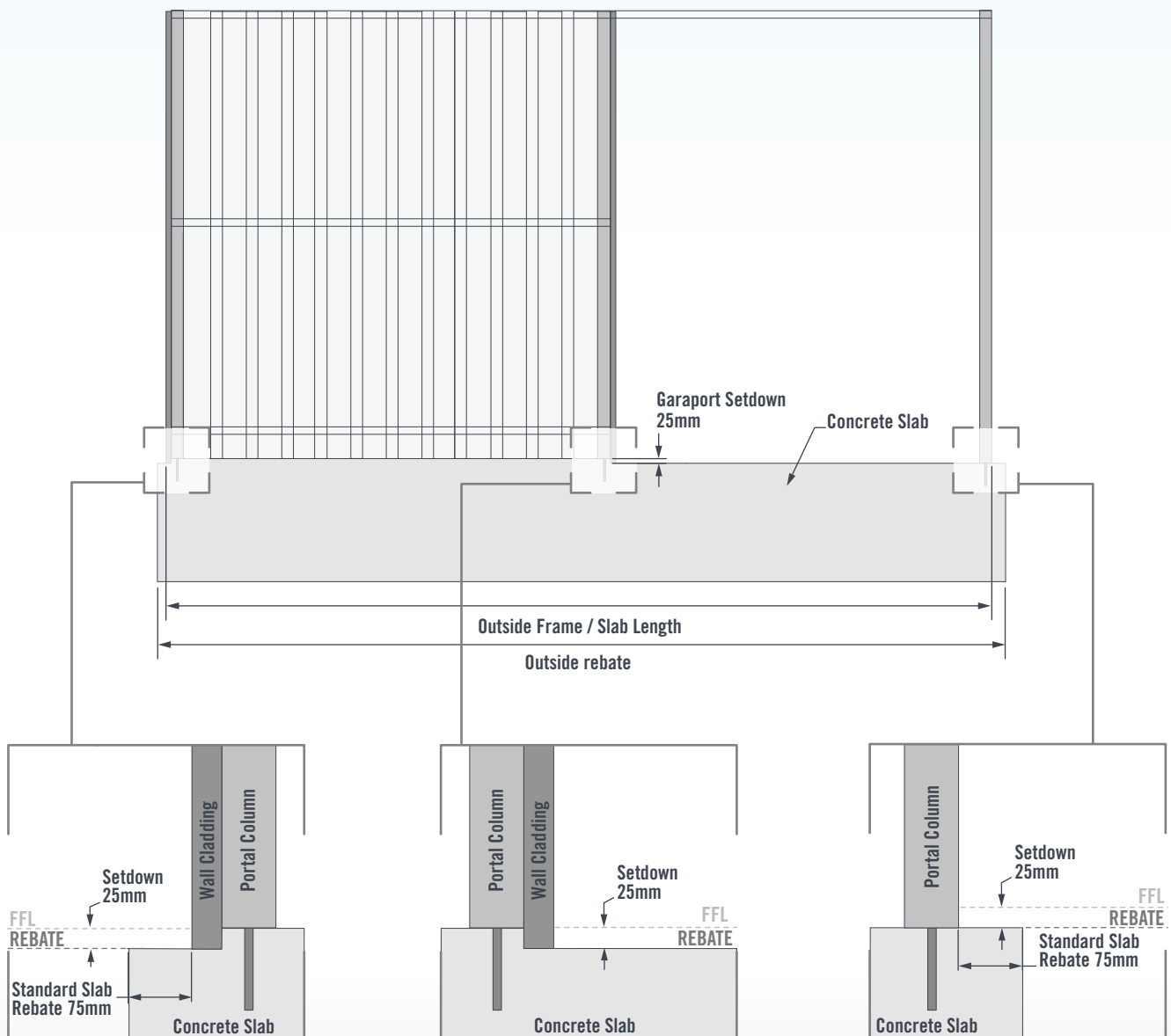


FIGURE 7.5

## OPENINGS - SLAB REBATES

For sheds with a concrete slab, it's recommended that a 25mm rebate is implemented for roller doors. This 25mm rebate (setdown) will provide additional weatherproofing and prevent water ingress under roller doors.

Note that all columns are fixed on the finished floor level (FFL), while the rebate is cut in around each column and set-down 25mm below FFL.

The images on this page provide an example for slab details, however your slab will vary depending on opening size, locations, etc.

If unsure of slab rebates, please contact Stratco for further information specific to your design of shed.

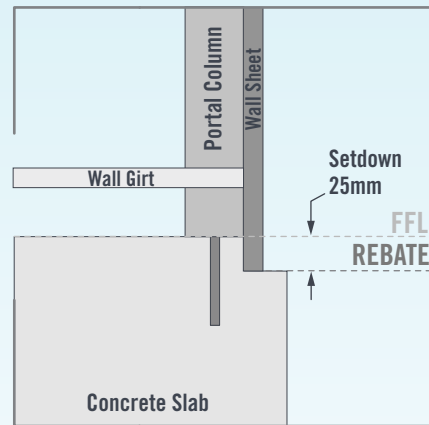


FIGURE 7.6

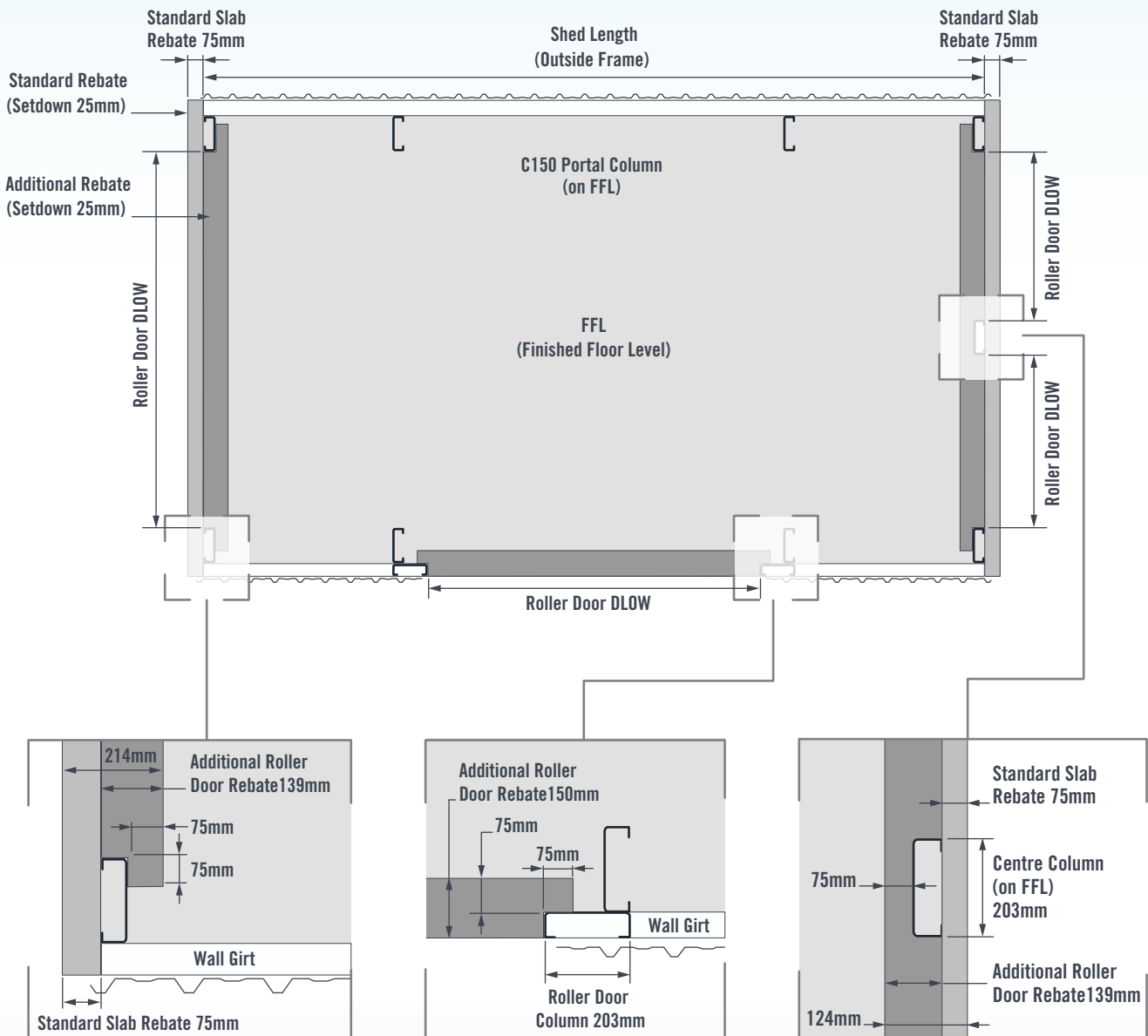


FIGURE 7.7

## SLIDING DOOR - SLAB LAYOUT (GUTTER SIDE)

### EXTRA DETAILS FOR SLIDING DOORS

For sheds with sliding doors, the slab design will need to be adjusted to accommodate the side(s) with doors.

Refer Section 7 Slab Preparation for details on the standard slab layout.

Use the standard slab layout as a starting point, then add additional width or length to the slab for any walls that are configured with sliding doors.

It is recommended to use a 25mm rebate (setdown) for the slab edge where sliding doors are positioned. The recommended rebate will help provide weatherproofing and the extra section of concrete will support the sliding door guideblocks. The additional recommended sliding door rebate is only required for the length of the (open) sliding doors. Locate the correct install page for your door configuration, (type, position and number of doors).

### FILLER COLUMNS

When installing gutter side sliding doors on end bays, filler columns are required to bridge the gap between the portal column and the sliding door frame.

Where a shed is pinned onto concrete, the filler column should be positioned on the 25mm rebate (setdown) part of the slab, and the rebate should be shaped to accommodate the filler column where appropriate.

A C100 filler column will be supplied for sheds with single and double sliding doors, and a C200 filler column supplied for sheds with double side-fix doors.

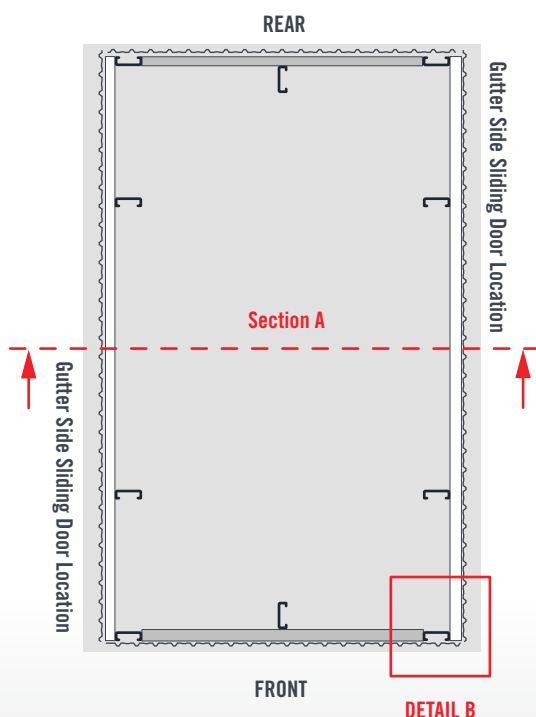


FIGURE 7.8

### SINGLE TRACK SECTION A

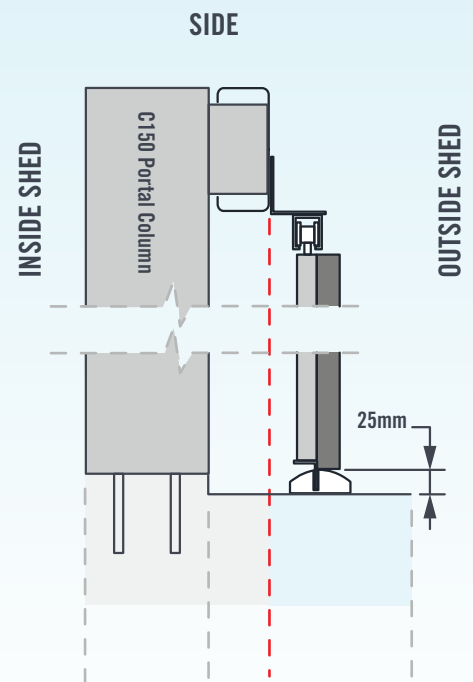


FIGURE 7.9

### DETAIL B

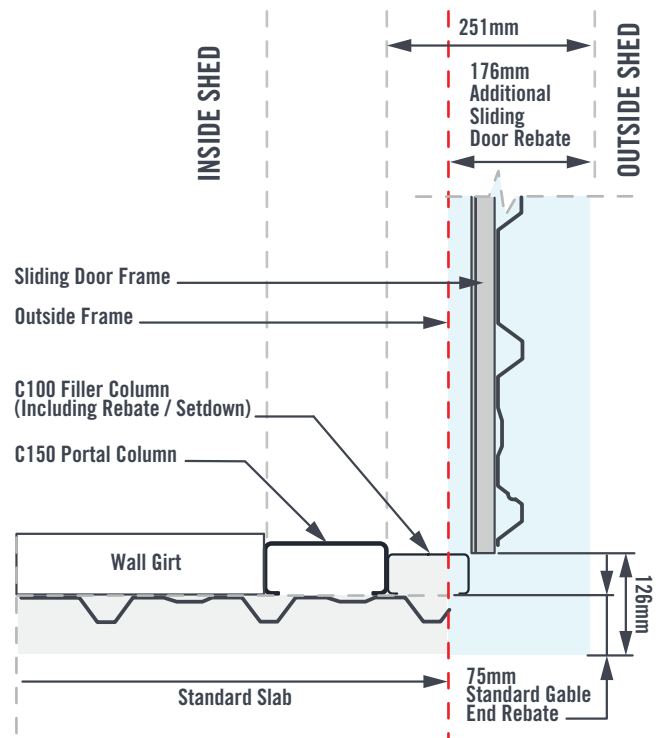


FIGURE 7.10

## DOUBLE SLIDING DOORS SECTION A

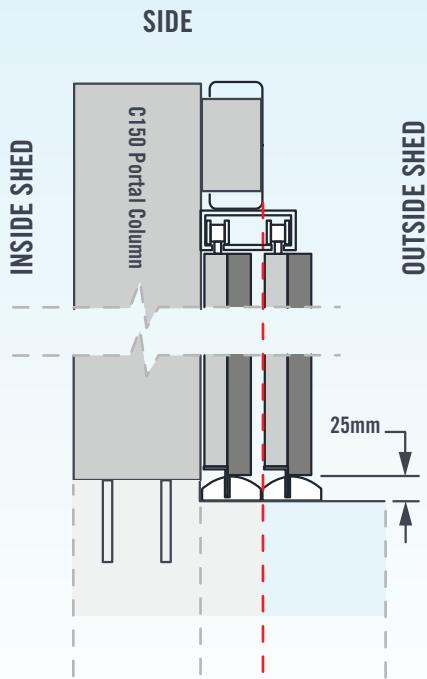


FIGURE 7.11

## DOUBLE SIDE-FIX DOORS SECTION A

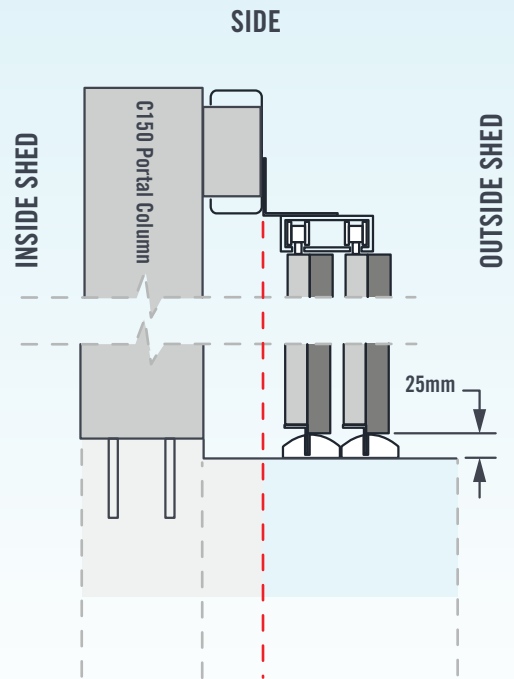


FIGURE 7.13

## DETAIL B

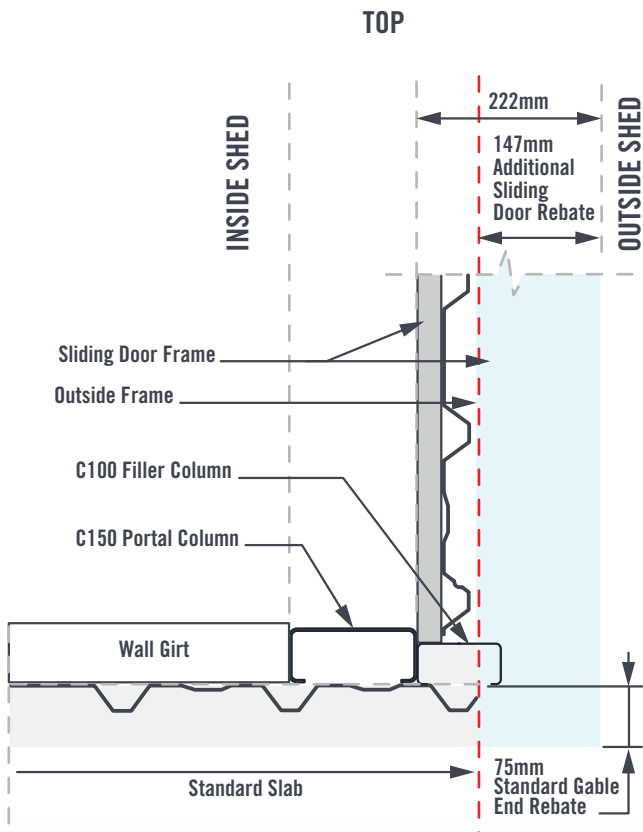


FIGURE 7.12

## DETAIL B

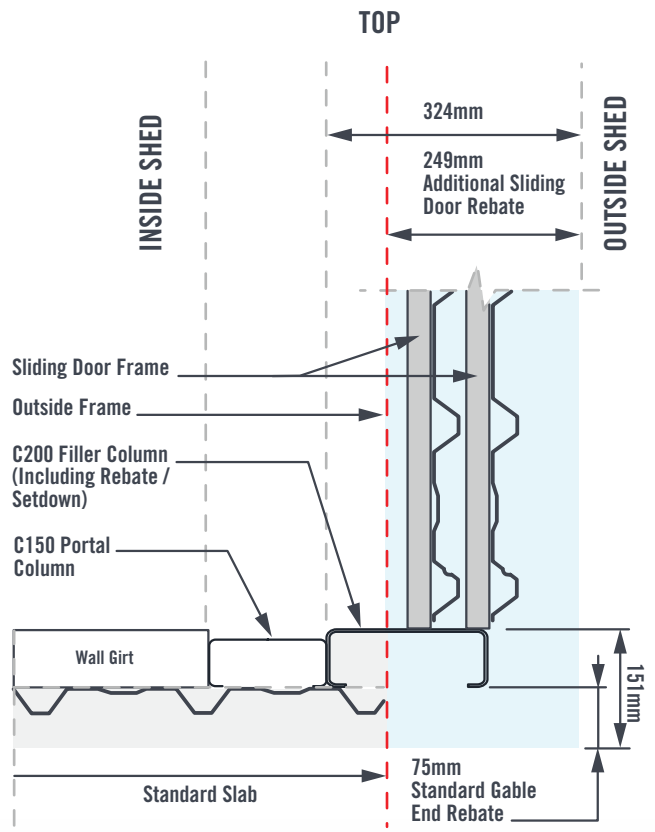


FIGURE 7.14

### SLIDING DOOR - SLAB LAYOUT (GABLE END)

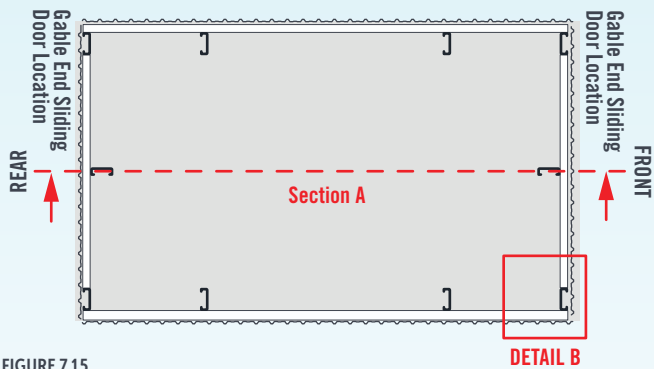


FIGURE 7.15

### SINGLE TRACK SECTION A

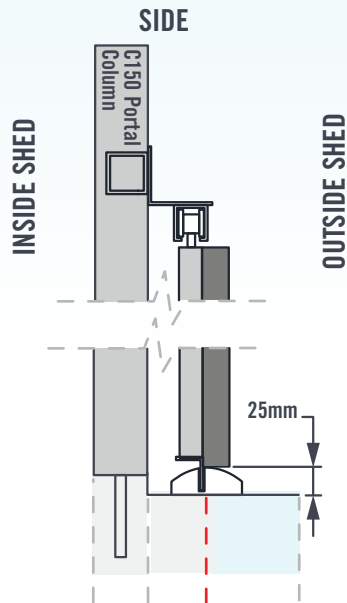


FIGURE 7.16

### DETAIL B

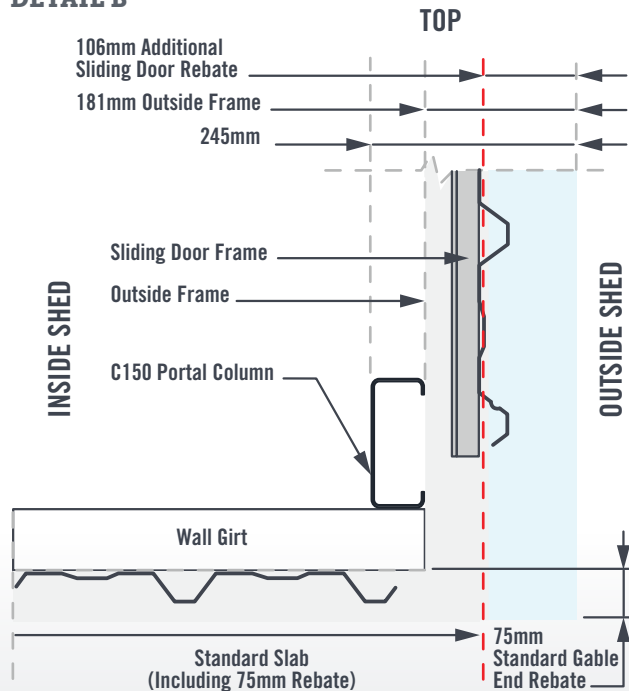


FIGURE 7.17

### DOUBLE TRACK - SECTION A

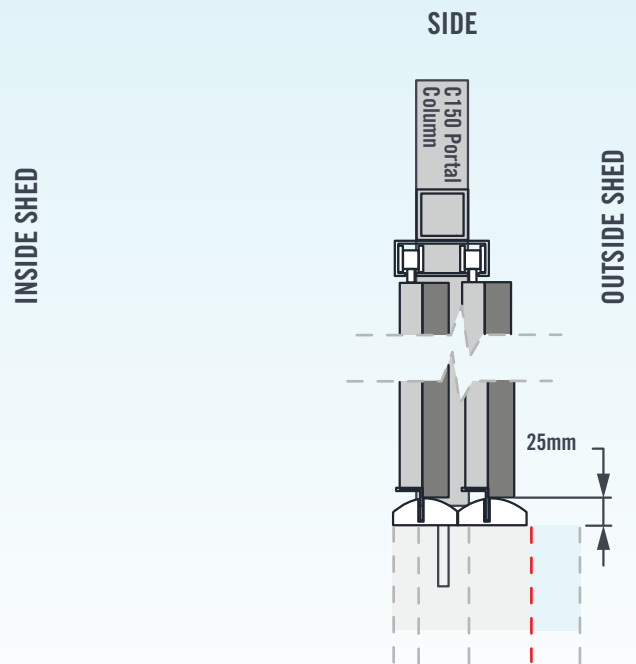


FIGURE 7.18

### DETAIL B

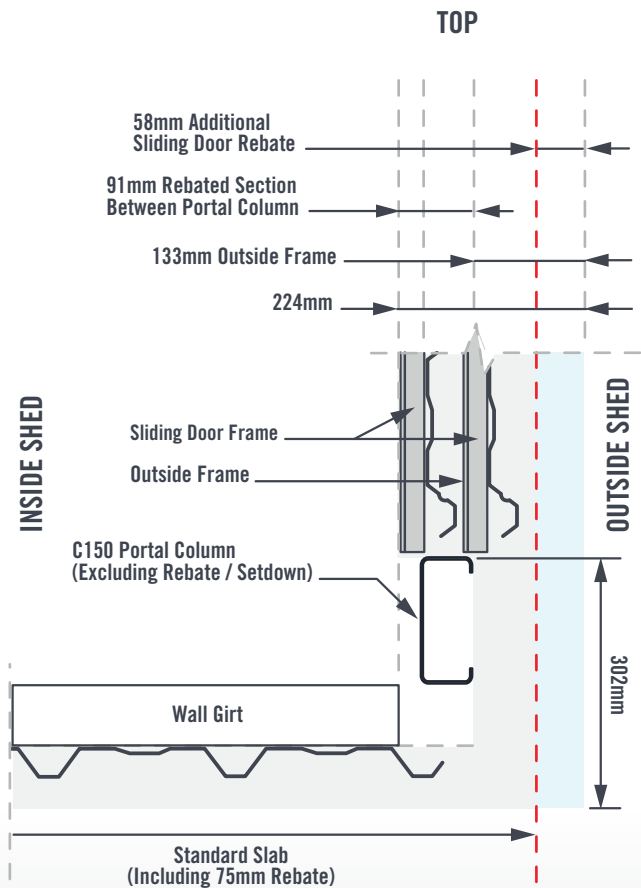
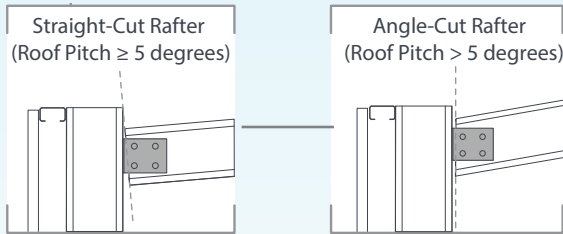


FIGURE 7.19

## 8. PREPARING THE FRAME

### SKILLION SHED RAFTERS

Rafters for Skillion roof sheds may need to be angle-cut at each end to ensure adequate room for the GP Bracket bolt connections.



Start by test fitting the General Purpose brackets to the Portal Columns with M12x30 flanged purlin bolts. Test fit a rafter in position between columns, supported by props underneath. Ensure that the pitch is correct and the C-section webs are orientated correctly. Mark out the hole locations for the GP Brackets on the rafter, then remove the rafter and drill web holes on the ground. You may use the first rafter as a template for the others to ensure an identical fit for all rafters.

If back to back rafters or columns are required, they will need to be fixed together with 12x20 screws or flange purlin bolts (if pre-punched). Note the fixings for B2B members will be spaced at max. 450mm centers. For back to back members, ensure there are fixings within 100mm of each end of the member.

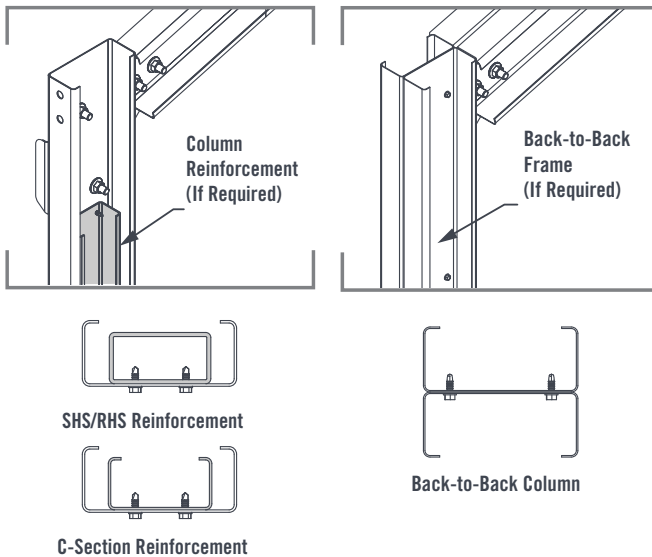


FIGURE 8.1

### BACK-TO-BACK COLUMNS & REINFORCEMENT

If C-Section or SHS/RHS column reinforcement is required, fix to column with two 12x20 screws or S-500 spaced 50mm apart, at maximum 450mm intervals along the length of the column. Ensure screws are within 100mm of each end of the reinforcement section. Column reinforcement should run from the base of the column to the underside of the eaves bracket, or the full length of the column on a Skillion Roof Shed.

If the shed will be fixed in ground, the reinforcement should be embedded to the same depth as the column.

### KNEE BRACING

Depending on your design of shed, knee bracing may be required. C150 members will be supplied for this, and must be notched on site to fit with the columns/rafters.

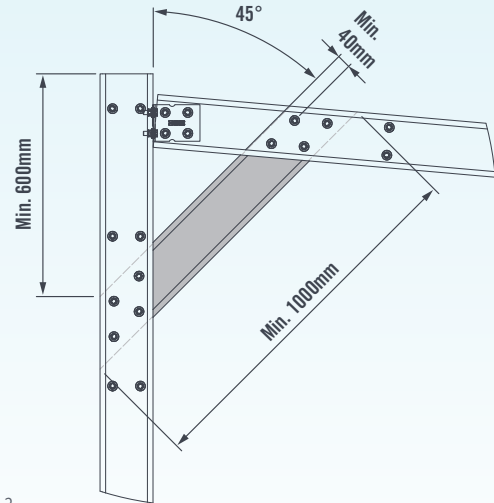


FIGURE 8.2

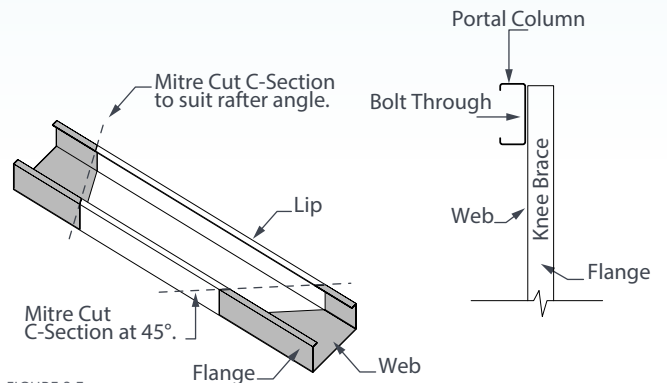


FIGURE 8.3

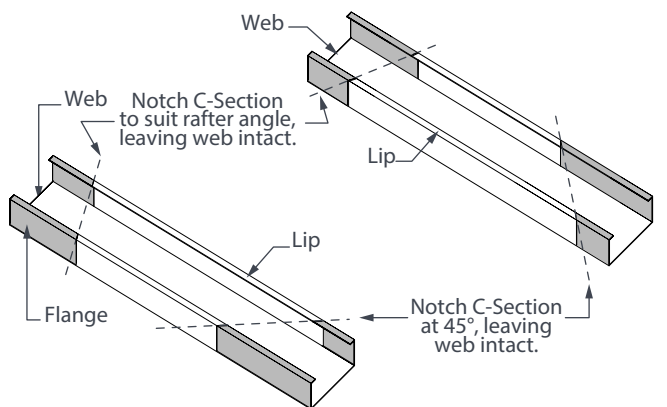


FIGURE 8.4

### ROOF CARRY BEAM

If your shed has a Roof Carry Beam, a Full Length Header Beam will be required along the same side of the shed as the Carry Beam. Refer to Section 22 for details on installation of a Full Length Header Beam.

Carry Beams and Rafters will require holes drilled on site to suit the position and location of the carry beam. 2x GP Brackets are generally required for each connection.

Carry Beam position can be influenced by several factors, so refer to job specific drawings for more information on carry beam position and always double check before drilling by using the short rafter as a guide. Once the carry beam position has been confirmed, use the GP Brackets as a guide to determine hole locations.

If installing a roller door, ensure the distance between the side wall of the shed and the Carry Beam is enough to accommodate the roller door barrel and hardware.

Lift the Roof Carry Beam into position and bolt to the webs of the Rafters using 2x Flanged Purlin Bolts through the short leg of each GP Bracket. The open Web of the carry beam should be facing out (ie facing the side wall closest to the carry beam).

2x GPBs will be required to join the short rafter to the web of the Roof Carry Beam. Bolt the long leg of a GPB to the web of the Short Rafter with 4x Flanged Purlin Bolt & Nuts. Join the short legs of the same GPBs to the web of the Roof Carry Beam with 2x Flanged Purlin Bolts in each Bracket.

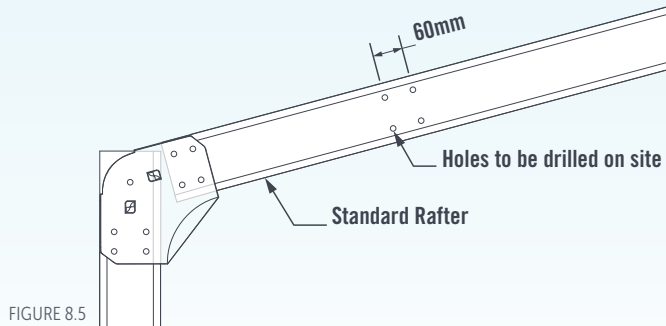


FIGURE 8.5

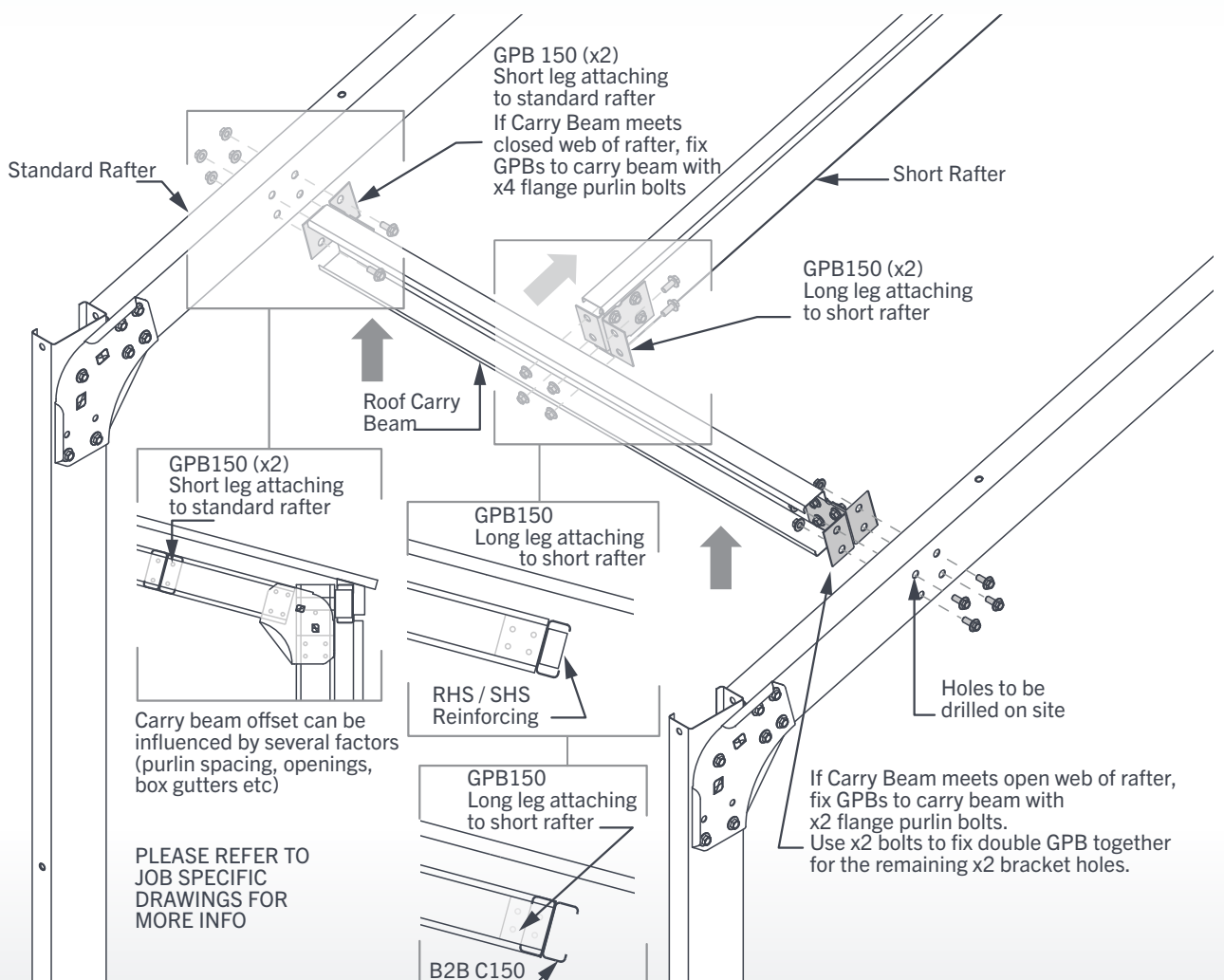


FIGURE 8.6

## 9. BRACING

### ROOF & WALL BRACING

The install guide will show the below warning at stages where strap bracing is typically required. Bracing amount and position will depend on structural/engineering requirements. When this reminder is shown, please refer to documentation specific to your shed for the correct bracing requirements.

#### CHECK BRACING REQUIREMENTS !

Bracing will be located in wall and roof bays where required, directly behind wall girts or roof purlins and screwed to the portal frame columns or rafters. All strap bracing is to be tensioned using bracing tensioners. In some cases, double Strap bracing may be required.

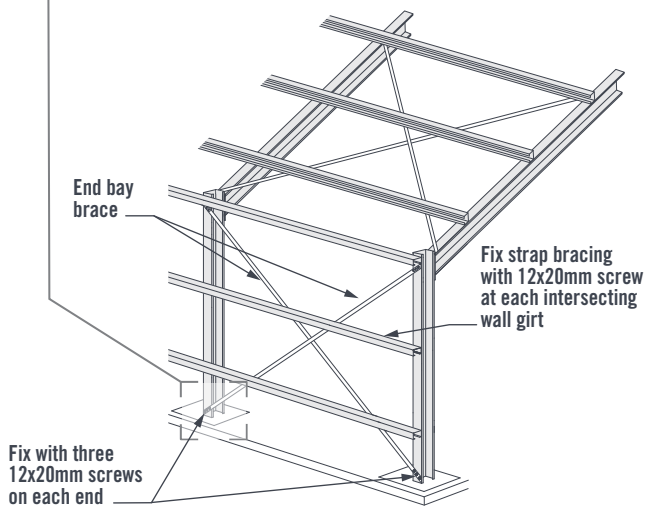
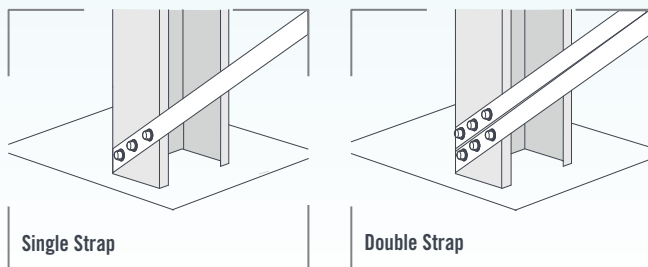


FIGURE 9.1

### STRAP BRACING IN NARROW BAYS

Where a strap bracing is required the angle of a single set cross brace must be between 30° - 60°.

Where a single set of cross brace falls outside of this angle range, a double set of cross bracing shall be applied in order to achieve an effective brace.

Where a double set of cross brace is used the cross brace shall be attached to the column/rafter as close as possible to a C75 purlin/girt.

### FLY BRACING

Where fly bracing is required, a fly brace must be fixed around the mid column or rafter. Fly bracing should be installed to match a 45° angle to the purlin/girts.

For cases that have back-to-back frames (usually seen in skillions), you may need to cut lengths from the strap brace rolls supplied to use for fly bracing.

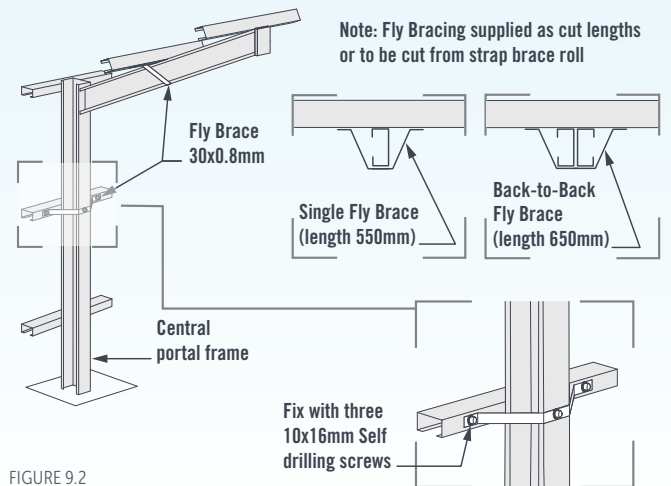


FIGURE 9.2

## 10. CONSTRUCTING THE WALLS

**NOTE:** this section details assembly of side walls without openings. If your shed has openings in the side walls, please read the relevant section (18-22) in conjunction with this section.

### WALL FRAMES

Lay C-section columns on the ground, making sure the open side of each column is facing the correct way, see job specific drawings for details.

As a general rule, the open side of each column will face the rear of the shed, except for the front columns which face the front of the Shed.

Please note that in standard sheds the columns have been pre-punched at every wall girt/column connection, and at the rafter/eaves connection. If your frame requires holes to be drilled, please refer to Section 8 Preparing the Frame for more information before proceeding.

### WALL GIRTS

Similarly, in standard sheds the wall girts have been pre-punched at each wall girt/column connection.

Place the wall girts across the columns and match the pre-punched holes.

Fasten the top girt to the column with a high-tensile 12x30mm flanged purlin bolt through each hole. The top girt is fixed through the top pre-punched hole in the columns.

#### Note:

- If side walls will have openings, please refer to the relevant section for further details (Opening Details, Sections 18-24)
- If a box gutter is to be installed, the top wall girt will be offset from the top of the column by 100mm, see Section 16 Box Gutter Installation.
- If your shed is NOT a 15° gable with CGI roof cladding, additional top girt capping flashings may be required.

### STRUCTURAL CAPPING FLASHING

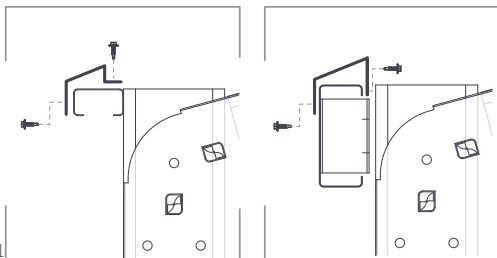


FIGURE 10.1

### GARAPORT FLASHINGS

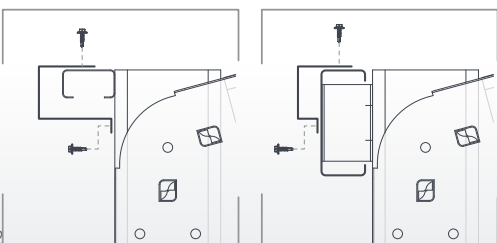


FIGURE 10.2

### JOINING WALL GIRTS

Where wall girts or purlins are to be joined over a single C-section, a girt joiner is required. The connection of wall girts shall only occur over portal or end column/columns, and the joining of purlins only over rafters.

Join the joining plate to the girts with two 12x30mm flanged purlin bolts. The centre hole must be used to join to the centre portal frame with one 12x30mm flanged purlin bolt.

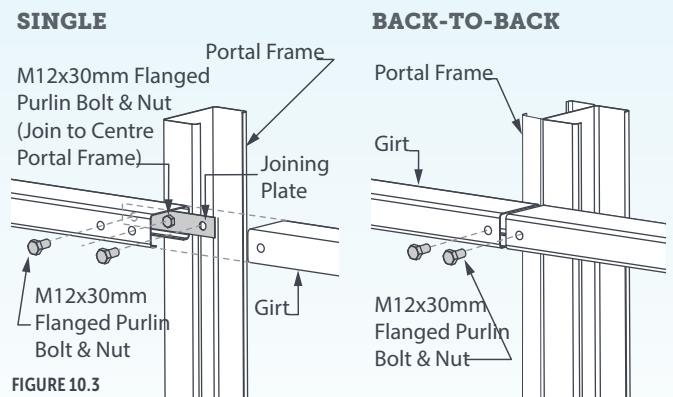


FIGURE 10.3

### TOE Mould FLASHINGS

Toe Mould flashings can be supplied to seal any gaps between the base of the wall sheets and the slab. There are two different types offered - one caps over the edge of the slab, the other sits atop the slab. Both fix through the lowest wall girt.

#### RECOMMENDED SLAB / TOE MOLD EXAMPLE

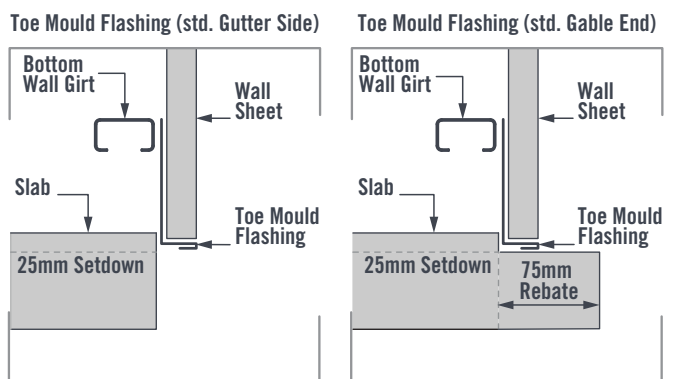


FIGURE 10.4

#### OPTIONAL SLAB / TOE MOLD EXAMPLE

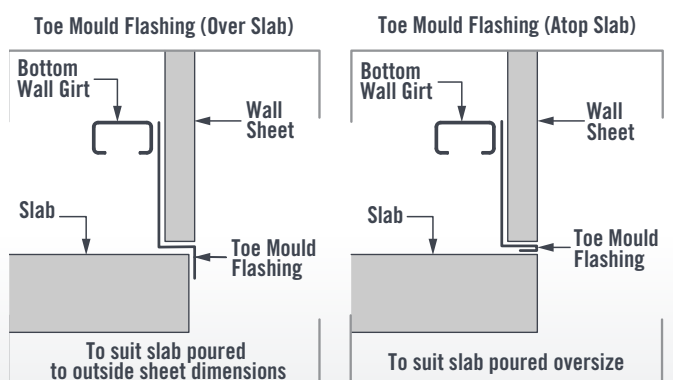


FIGURE 10.5

**CHECK BRACING REQUIREMENTS!**

**WALL SHEETING**

**Note:** If cladding with Hiland Tray, it is recommended that all framework is fully assembled before installing Hiland Tray sheets and flashings. Refer to Section 14 for Hiland Tray installation details.

Ensure the framework is square and the diagonal measurements are equal. Start laying the sheeting from the back-end of the shed, to make sure the overlap seam is not visible from the front of the shed. Ensure the top edge of the wall sheets are aligned parallel with the top edge of the top wall girts.

Fix the wall sheets with 10x16mm self drilling screws at every girt junction. The sheets are laid with the short rib overlapping. Before fastening all screws, run a string line from both ends of the wall panel through the centre of the girts to ensure all the screws will be fastened in line.

For 15° gable sheds, the top of each wall sheet should be 5mm below the top wall girt. This will prevent any rubbing between the wall and roof sheets. Other roof pitches may require a different spacing for appropriate clearance, so double check job specific documents for more information. Check the wall frame remains square as the wall sheets are fixed.

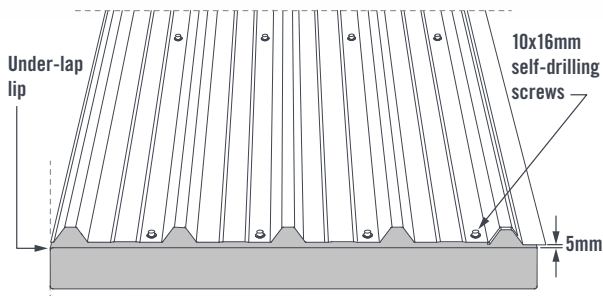


FIGURE 10.6

**NOTE:** WALL SHOWN IS POSITIONED ON THE GROUND BEFORE STANDING INTO PLACE.

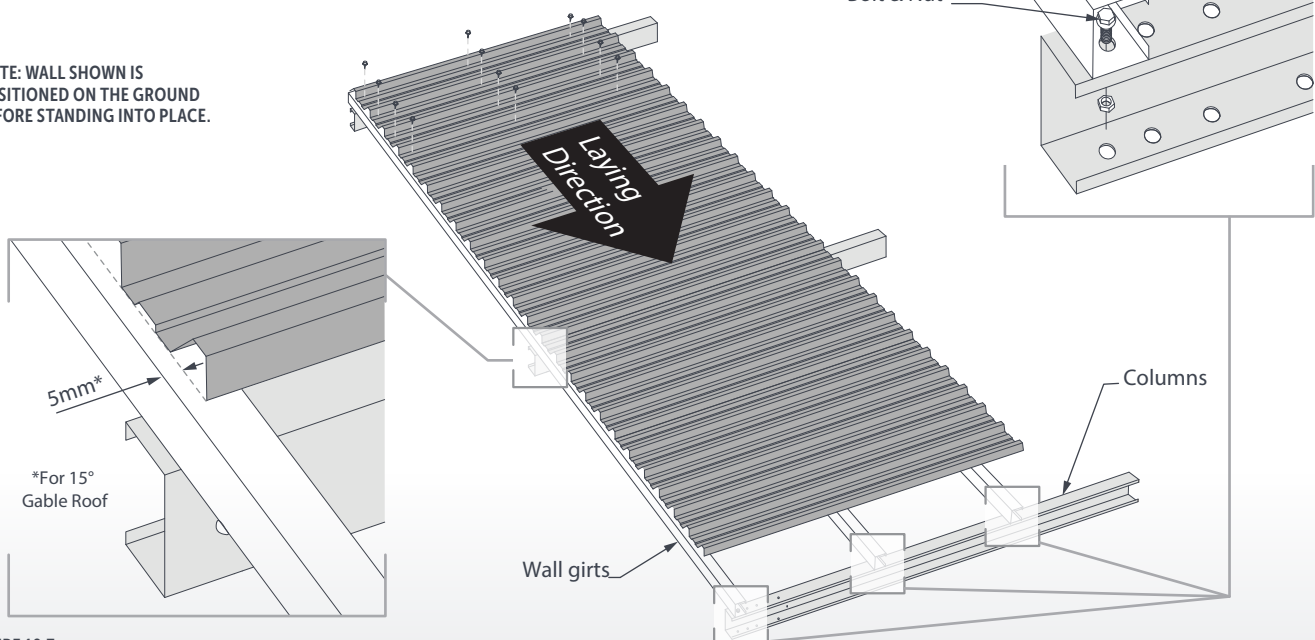


FIGURE 10.7

**WALL SHEET PROFILES**

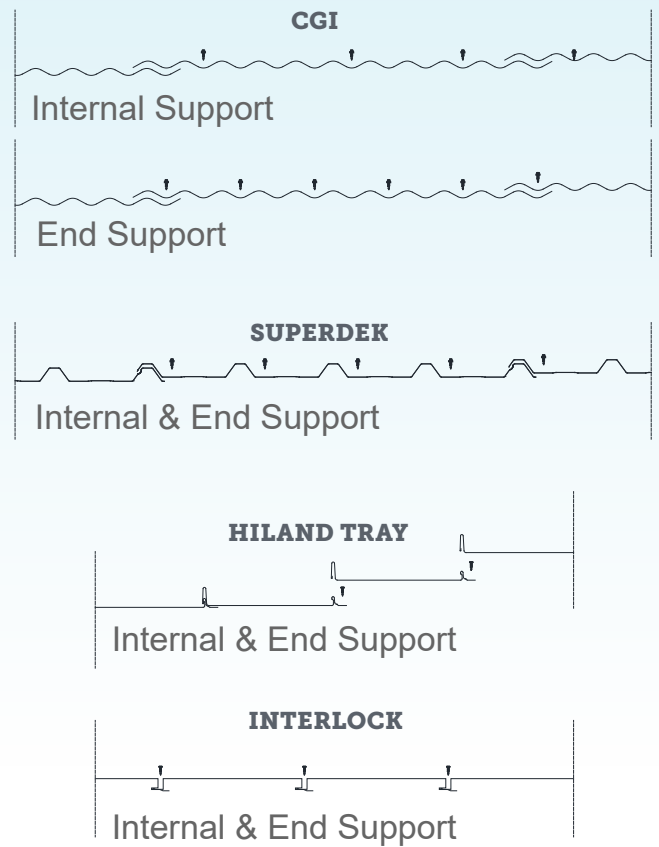


FIGURE 10.8

## 11. BUILDING THE FRAME - GABLE ROOF SHEDS

### STANDING THE WALL FRAME

Stand the completed wall frame in the footing holes, and temporarily brace it. Make sure the wall is level and square.

Repeat for the other side wall frame. Stand the two wall frames in the holes and brace them securely. If fixing to concrete do not remove bracing until columns are fixed to concrete.

### RAFTERS

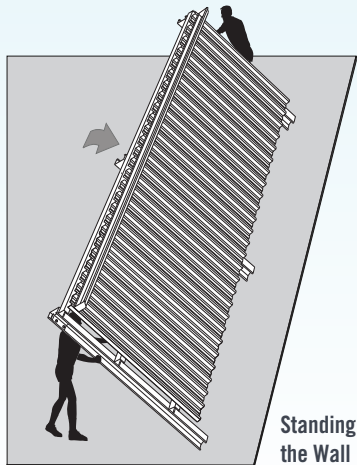


FIGURE 11.1

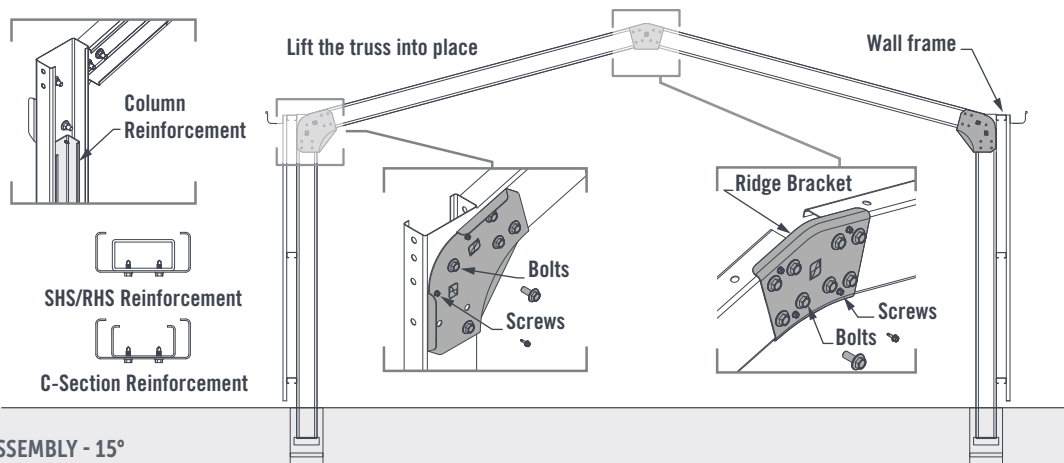
The rafters are bolted together on the ground using a ridge bracket. Lay two rafters out, ensuring the C-sections are orientated correctly (orientation of web on each rafter should match orientation of web on columns).

Bolt the eaves bracket to each end of the rafter frames with four 12x30mm flanged purlin bolts (note, if strengthening washer plates are provided, install them now). Alternatively the eaves brackets can be fastened to the ends of the columns first. The ridge bracket and rafter frame can then be lifted into position and bolted through the eaves brackets.

Bolt the ridge bracket in place by lining up the rafter and ridge bracket holes. Use a 12x30mm high tensile flanged purlin bolt in each hole and tighten. To eliminate any movement in the joint, screw four 12x20mm self drilling hex head screws through the ridge bracket and into each rafter.

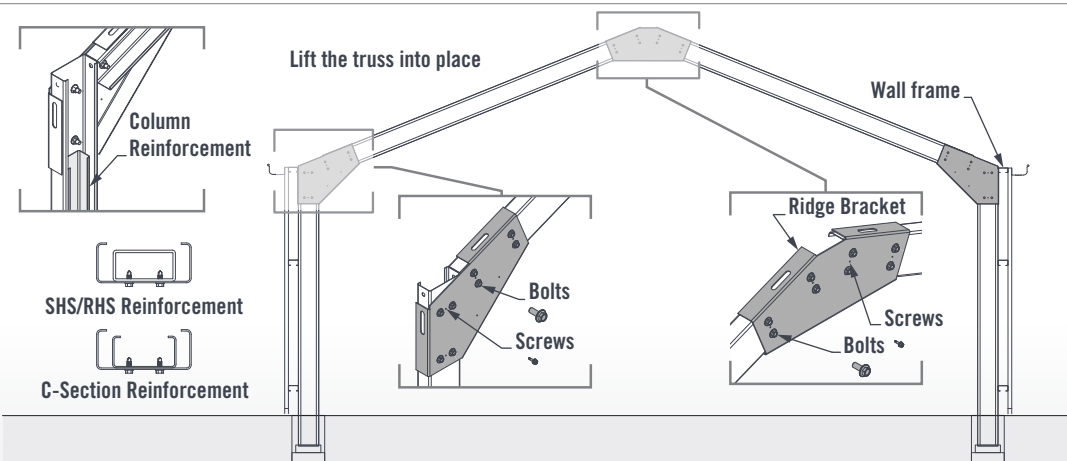
### RAFTER ASSEMBLY

Use a person on each end of the rafter assembly to lift the frame into position. Bolt the eaves brackets to the column ends with three M12x30 high tensile flanged purlin bolts. Attach all the intermediate rafter assemblies first for stability, then the front and rear assemblies as previously described.



PORTAL FRAME ASSEMBLY - 15°

FIGURE 11.2



PORTAL FRAME ASSEMBLY - ALTERNATE PITCH

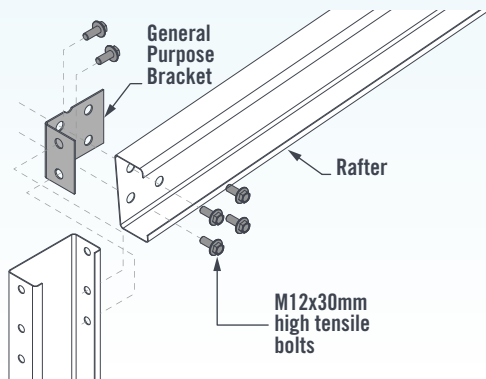
FIGURE 11.3

## 12. BUILDING THE FRAME - SKILLION ROOF SHEDS

### RAFTERS

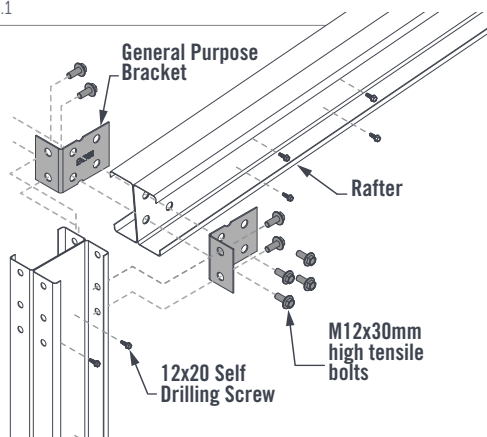
Skillion sheds generally require rafters to be drilled to suit GP Brackets, prior to assembly. Additional prep work including notching and drilling of other members (rafters, knee bracing, etc) may also be required before standing the frame. Please refer to Section 8 Preparing the Frame and ensure all framing is prepared for assembly.

If back to back rafters are required, they will need to be fixed together with 12x20 screws or flange purlin bolts (if pre-punched). Note the fixings for B2B members will be spaced at max. 450mm centers. If screw fixing is required, ensure screws are within 100mm of the general purpose brackets at each end of the rafter.



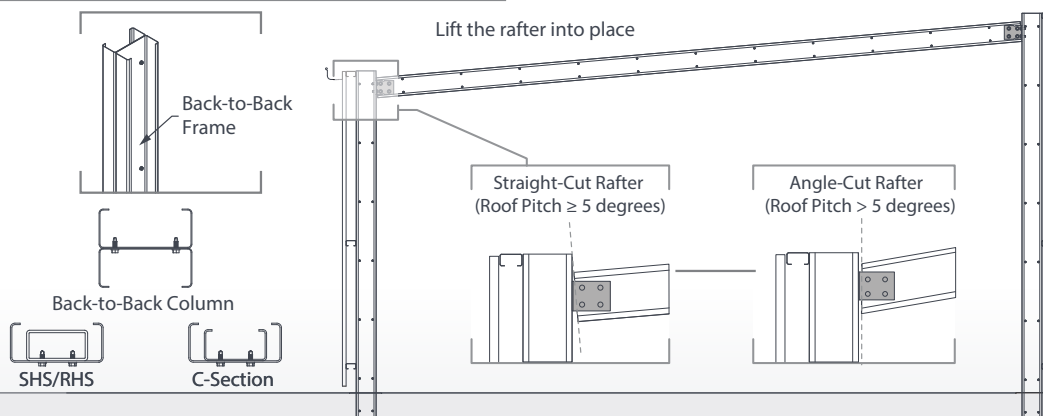
SKILLION FRAME CONNECTION - SINGLE

FIGURE 12.1



SKILLION FRAME CONNECTION - BACK TO BACK

FIGURE 12.2



SKILLION FRAME ASSEMBLY - 5° EXAMPLE

FIGURE 12.3

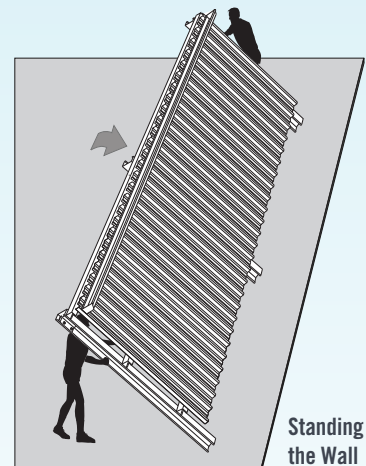


FIGURE 12.4

### STANDING THE WALL FRAME

Stand the completed wall frame in the footing holes, and temporarily brace it. Make sure the wall is level and square.

Repeat for the other side wall frame. Stand the two wall frames in the holes and brace them securely. If fixing to concrete do not remove bracing until columns are fixed to concrete.

### RAFTER ASSEMBLY

Use a person on each end of the rafter to lift into position. Bolt the rafter to the GP Brackets installed on the columns with four M12x30 high tensile flanged purlin bolts.

Alternatively, the General Purpose Brackets can be installed on the ends of the rafters first. The rafter assembly can then be lifted into position and bolted through the flange of the Skillion Columns. Attach all the intermediate rafter assemblies first for stability, then the front and rear assemblies as previously described.

### 13. END WALL INSTALLATION

#### END COLUMNS

If your Shed requires an end wall column (C100 or C150), install this before assembling the end wall girts. Fix the top of the column by bolting through the rafter/ridge bracket using one M12x30mm flanged purlin bolt, and either fixing in ground or bolting to concrete using the appropriate footing details..

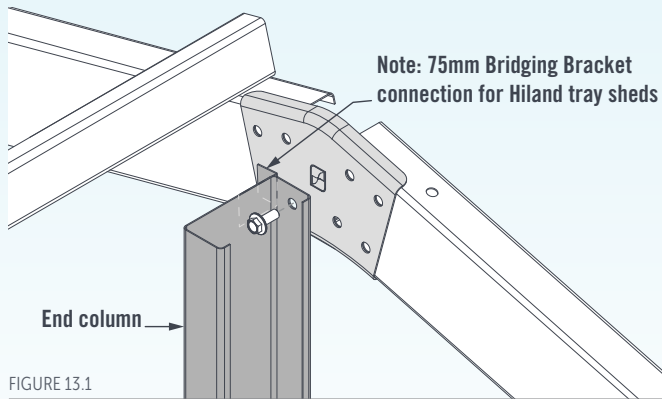


FIGURE 13.1

#### REAR WALL GIRTS

Check the frame is square and level before fixing the end wall girts. Fix end wall girt brackets to both rear columns with two 10x16mm self drilling screws per bracket leg.

Span wall girts between each bracket and fix with two 10x16mm self drilling screws through each flange.

Note: if cladding with Hiland Tray, ensure that the wall girts are aligned flush with the outside of the shed frame if Hiland Tray cladding is used.

Bolt the rear wall girts to the end column with one M12x30mm flanged purlin bolt & nut.

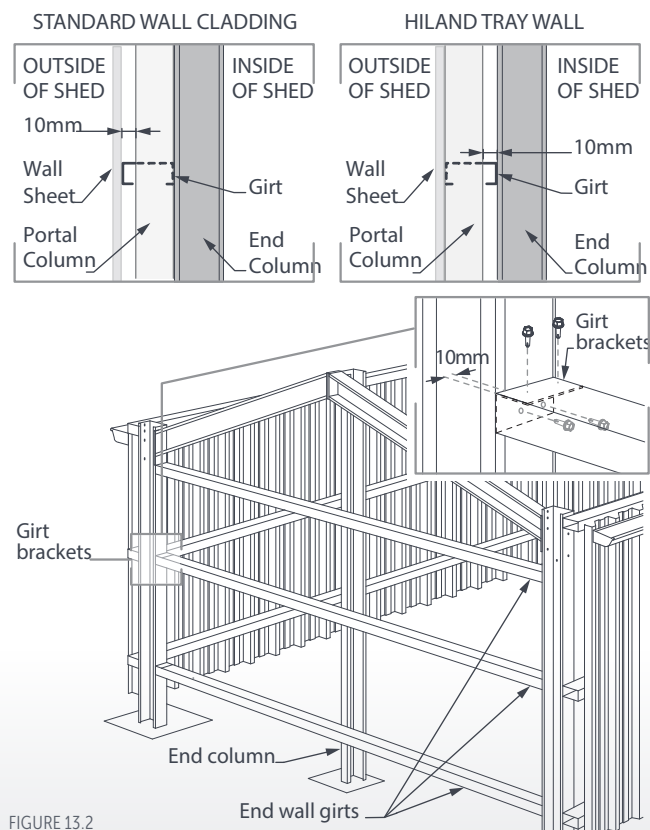


FIGURE 13.2

### CHECK BRACING REQUIREMENTS !

#### END WALL SHEETS

Before fixing the gable end wall sheets, locate the raking flashing so it sits on the edge of each purlin, following the roof line. Screw the raking flashing to each purlin with one 10x16mm self drilling screw.

Pan fix the gable wall sheets to the raking angle and frame with 10x16mm self drilling screws.

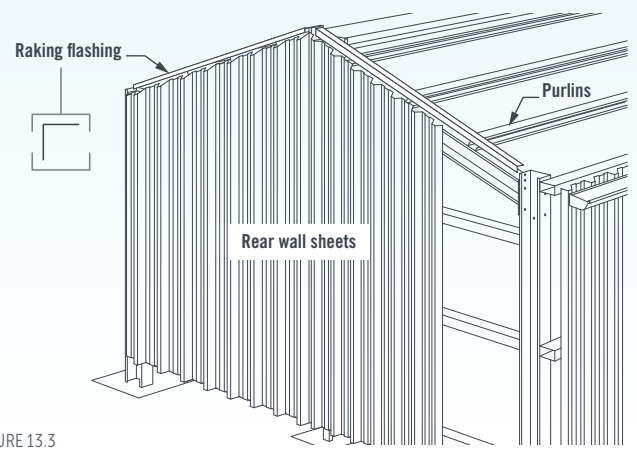


FIGURE 13.3

## 14. HILAND TRAY

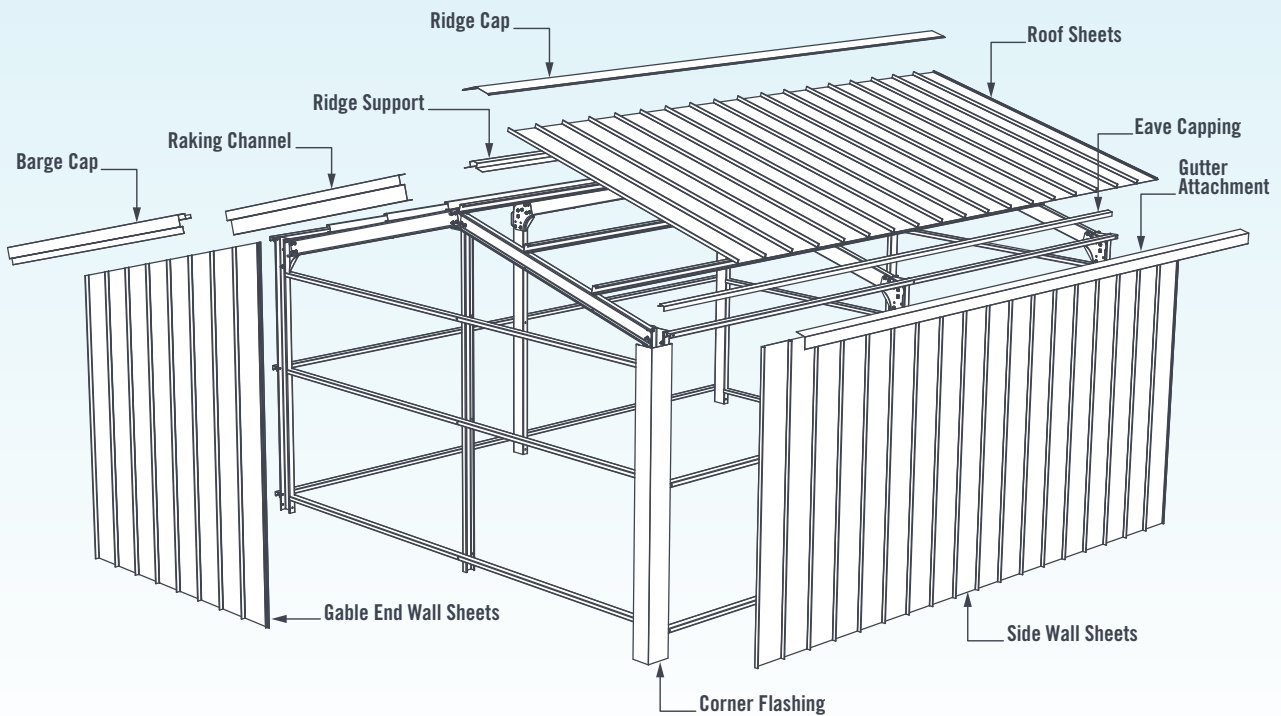


FIGURE 14.1

### HILAND TRAY END WALL GIRT ALIGNMENT

End Wall Girts should be aligned with the outside of shed framework when Hiland Tray is used. If a Gable End Column is required, it should be mounted to the end wall girts with M12x30 flanged purlin bolts. Use a 75mm Bridging Bracket to attach the end column to rafter.

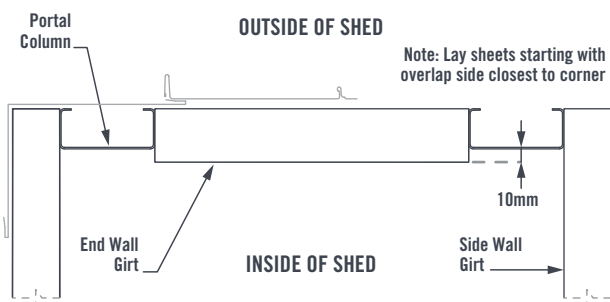


FIGURE 14.2

### RAKING CHANNEL AND CORNER FLASHINGS

On the end walls, install raking channel flashings on top of the roof purlins and to the underside of the rafters.

Install the corner flashings, noting the two faces of the flashing will have varying lengths depending on the size of the shed. It is critical that these are aligned correctly - refer to the elevations supplied with your Gable Roof Shed detailing the correct orientation and positioning of corner flashings and Hiland Tray sheets.

### SECTION VIEW - RAKING CHANNEL AND BARGE CAP

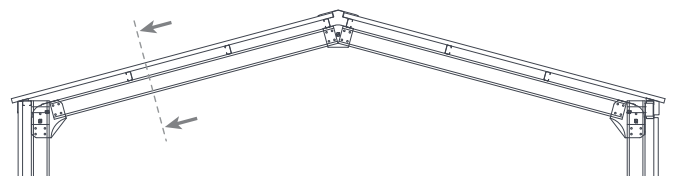
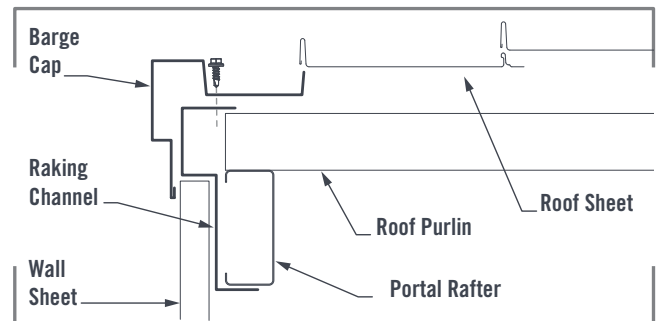


FIGURE 14.3

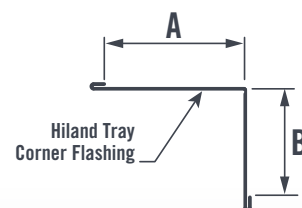


FIGURE 14.4

**CHECK BRACING REQUIREMENTS !**

**WALL SHEET INSTALLATION**

The sheet installation process is the same for both Gable Ends and Gutter Sides.

With the corner flashings installed, you can now begin to lay Hiland Tray sheets in place. Starting at one corner of the shed, position the overlap of the first sheet over the crest of the corner flashing, then fasten through the nailstrip side of the sheet with one Wafer Head screw at each girt. 10x16 Colour Self Drilling Screws can be used to fix the end sheet through the corner flashing.

The next sheet overlap will clip onto the underlap of the first Hiland Tray sheet, again securing the nailstrip side with Wafer Head screws. Repeat this process for remaining sheets, then cap the underlap of the final sheet and opposite corner flashing with a supplied "Double Overlap" sheet.

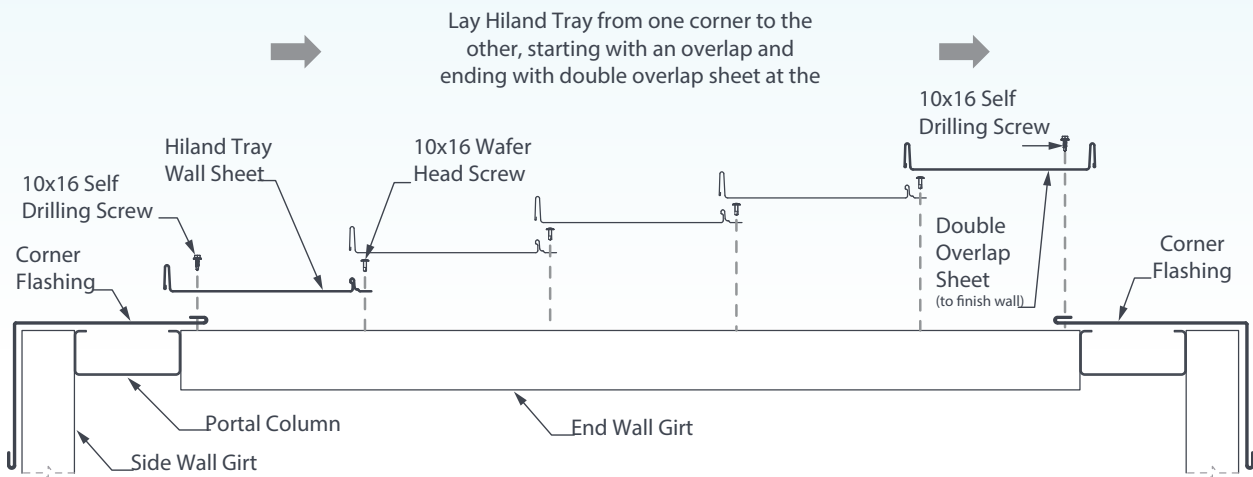


FIGURE 14.5

**OPENING AND DOOR CUTOUTS**

Where there are openings or doors in the shed, the Hiland Tray sheets will need to be trimmed around any openings for doors or windows in the shed. Always cut along the pan, as close to the opening edge as possible. Flashings will be supplied to cap the cut sheets, and a header flashing will be supplied to cap the underside of sheets above an opening.

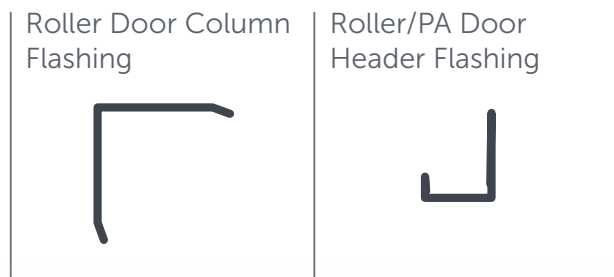


FIGURE 14.6

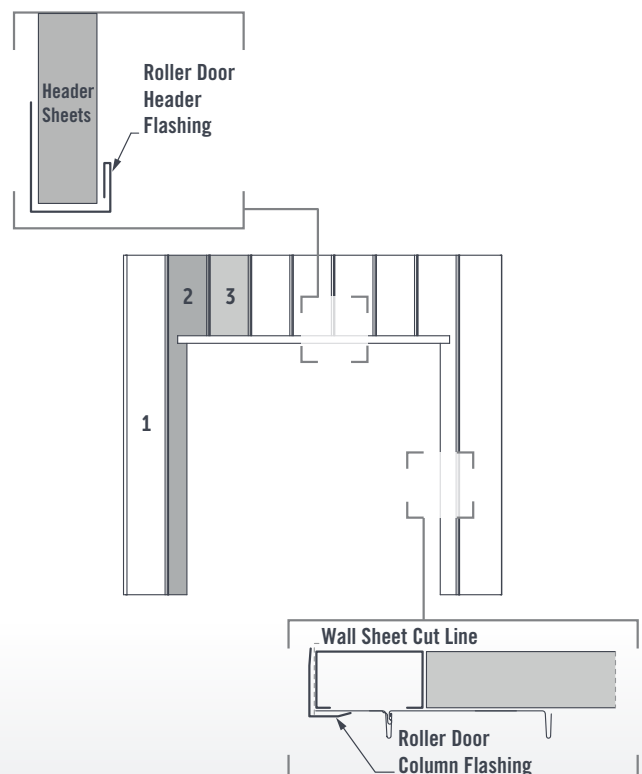


FIGURE 14.7

## 15. EXTERNAL GUTTER INSTALL

### QUAD GUTTER INSTALLATION - NSW, VIC, SA, QLD

Rivet a left and right hand stop end to each length of gutter. Seal stop ends with silicone.

Cut a hole for each downpipe outlet and rivet the outlet into position. Seal with silicone.

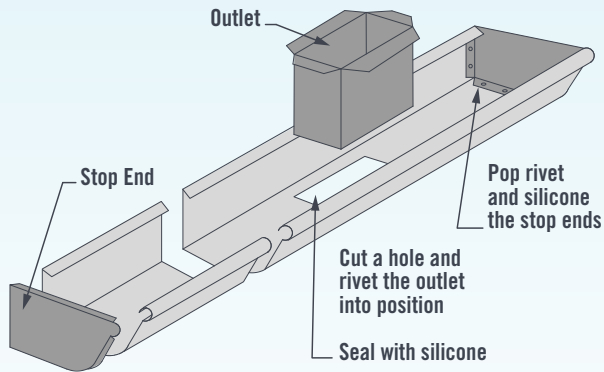


FIGURE 15.1

### QUARTER ROUND GUTTER INSTALLATION - WA ONLY

Mark the position of the P-Clip on the wall sheeting. Use a string line to mark out a slight fall towards the downpipe end so the water can flow freely. Drill holes and rivet the P-Clips in place.

To allow room for installing the timber fix bracket between the P-Clip uprights, use a pair of tin snips to remove the top section of the P-Clip. The base of the P-Clip supports the gutter, see Figure 28.

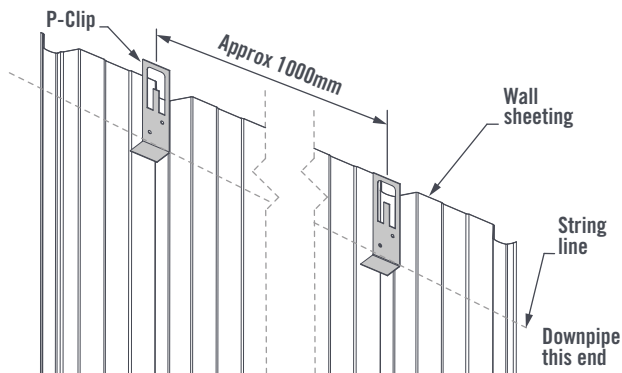


FIGURE 15.2

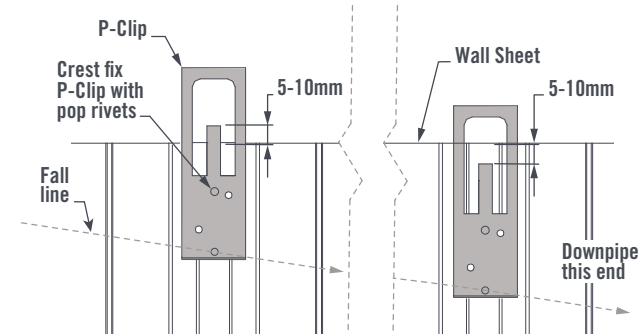


FIGURE 15.3

Once the gutter is in place, fold the tabs of the P-Clip over the top of the gutter to avoid interference with the timber fix bracket.

Crest fix the gutter brackets to the wall sheets at approximately 1000mm centres with 2-3 pop rivets or 10x16 tek screws. Allow for gutter fall of 1 in 500 (i.e gutter length  $6000/500 = 12\text{mm}$ ) for a slight fall towards the downpipe end so the water can flow freely.

Once the gutter brackets have been installed, roll the gutter bead onto the gutter brackets and clip the back of the gutter into position.

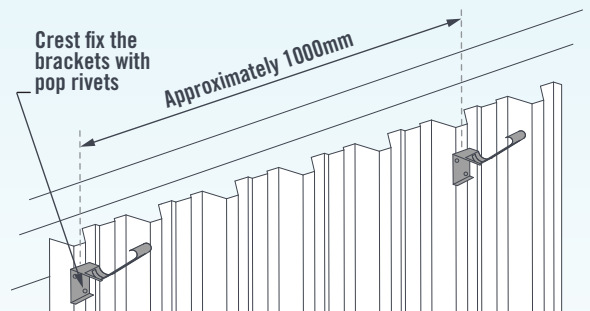


FIGURE 15.4

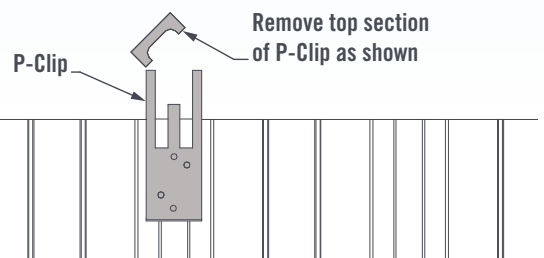


FIGURE 15.5

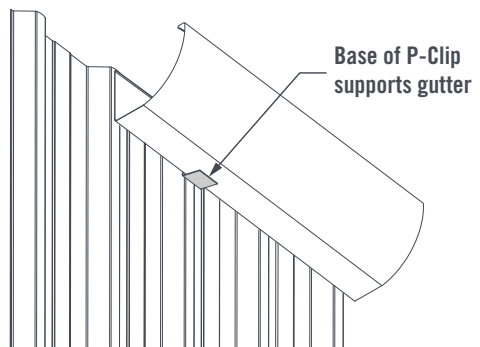


FIGURE 15.6

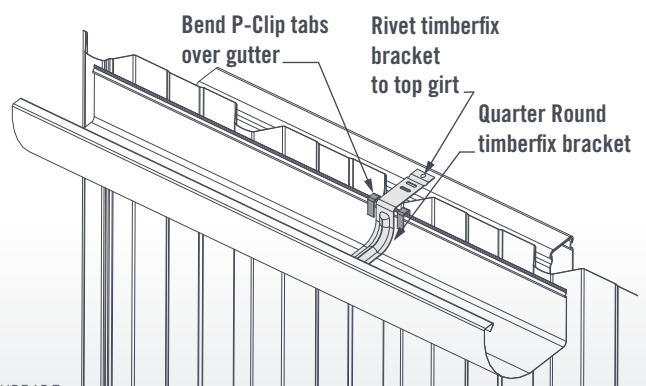


FIGURE 15.7

## EDGE GUTTER INSTALLATION

### EDGE GUTTERS

Rivet a left and right hand stop end to each length of gutter. Seal stop ends with silicone. Cut a hole for each downpipe outlet and rivet the outlet into position. Seal with silicone.

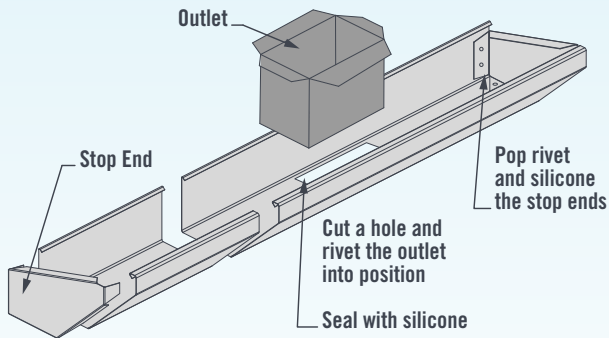


FIGURE 15.8

Fix the gutter to the crest of the wall sheets, or to the gutter attachment flashing if Hiland Tray is used. Allow for a slight fall towards the downpipe end so the water can flow freely.

Fix gutter straps at approximately 1000mm centres to the top of the eave purlin, hooking the strap under the bead of the gutter.

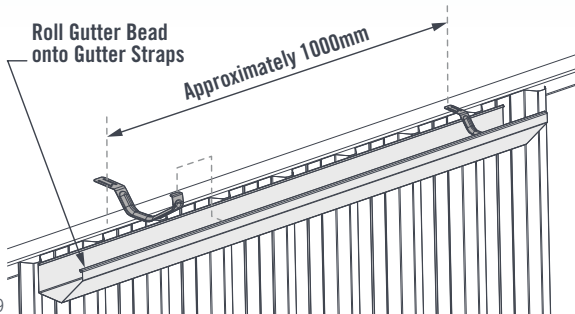


FIGURE 15.9

### DOWNPIPES

Slide the small end of one downpipe into the big end of the other. Rivet the downpipe at the back, then use a hacksaw to cut to the desired length.

Fix the downpipe to the existing outlet using rivets, then use downpipe straps to fix the downpipe against the wall using 10x16mm self drilling screws.

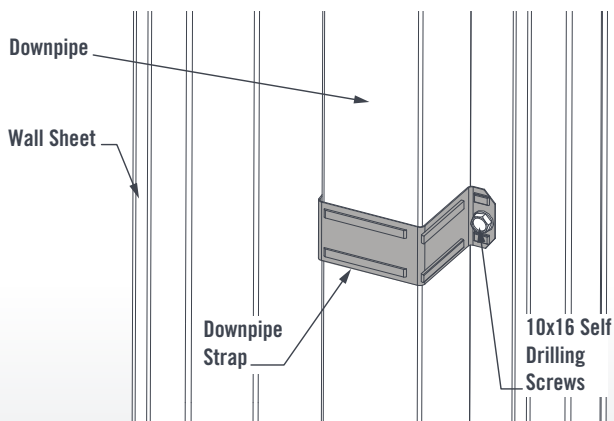


FIGURE 15.10

## 16. BOX GUTTER INSTALL

If a Box Gutter is used on your shed, the top wall girt will be installed lower on the box gutter side.

Fix the top wall girt to the columns with M12x30 flanged purlin bolts, double checking that the correct column hole has been used (box gutter height to top of column can be used as a guide).

Bolt the lowest roof purlin to the rafters with M12x30mm flanged purlin bolts - this will support the box gutter profile.

Fix the stop ends to the box gutter using rivets and seal with silicone.

The box gutter will be supplied slightly overlength to allow one end to extend past the wall of the shed and feed into a downpipe. This end will need to be notched/folded on-site.

Refer to the images on the next page for further details on notching the box gutter and downpipe installation.

Slide the box gutter into position onto the lowered top wall girt, ensuring the outside edge of the box gutter caps the wall sheet. Fix the box gutter to the wall sheets with 10x16 self drilling screws, at the same spacing as the wall sheet to girt fixings.

**Note: The end wall sheets for the box gutter side wall are 47mm longer than standard for 15° gable sheds.**

Use the box gutter profile as a template to mark and cut out a corresponding section of the gable wall sheet.

The corner flashing will need to be notched to allow for the box gutter.

Install the roof sheets, see Section 17 for details. Ensure the roof sheets are fixed to the additional purlin.

**Note: if your shed is a gable roof, the roof sheets for the box gutter side will be slightly shorter than the opposite side of the shed.**

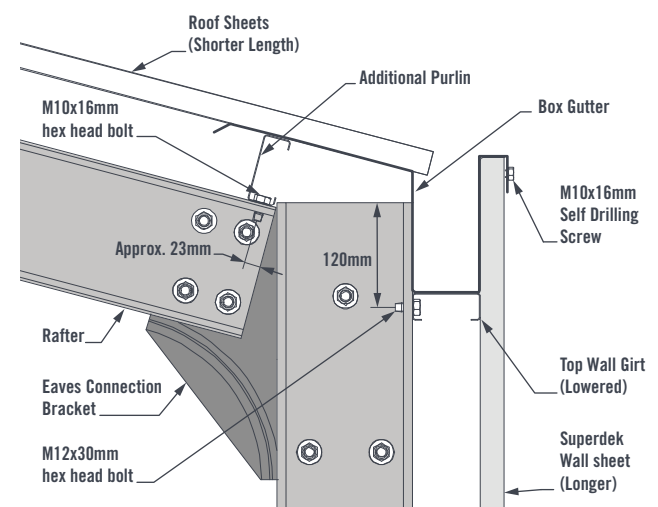


FIGURE 16.1

## 16. BOX GUTTER INSTALL

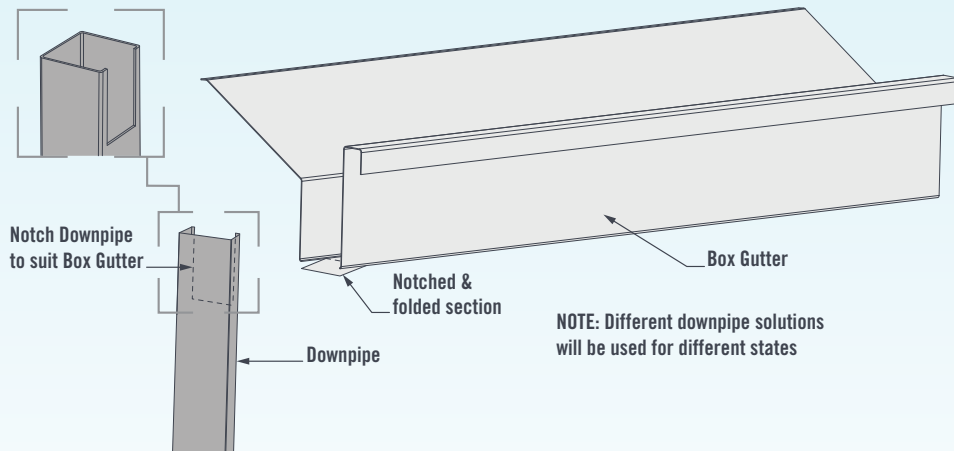


FIGURE 16.2

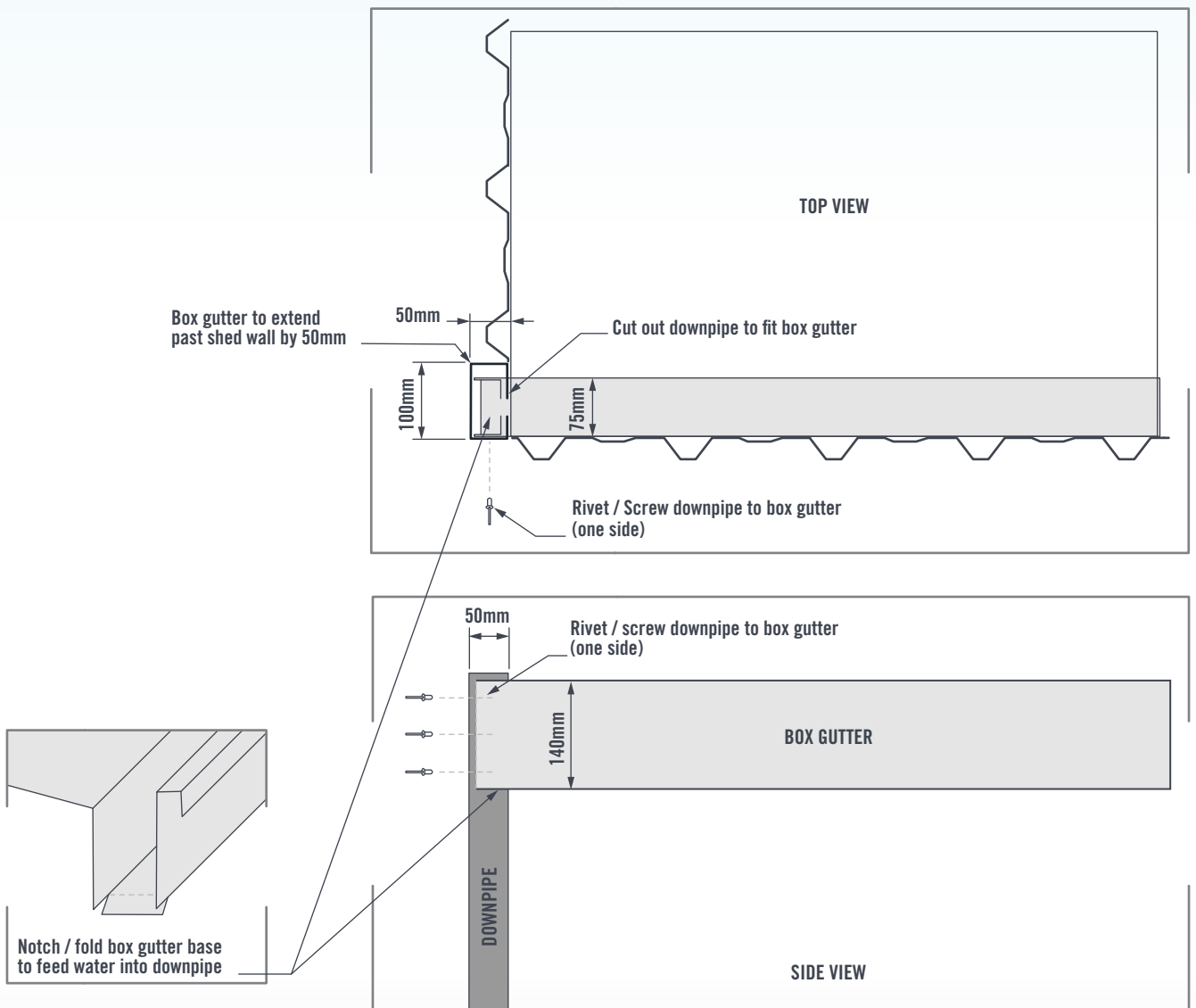


FIGURE 16.3

## 17. ROOF INSTALLATION

### PURLINS

Ensure the shed frame is square. Position the roof purlins across the rafters, match the pre-punched holes and bolt into position.

**CHECK BRACING REQUIREMENTS !**

### ROOF SHEETS

Refer to Figure 17.2 for typical roof sheet lapping and fixing details. Note, screw fixing quantity may differ depending on cladding type and support.

NOTE: Non-standard designs and sheds in high wind-speed/cyclonic areas will likely have special requirements. Always refer to shed specific documents and engineering to confirm requirements before starting install.

Note: for roof pitches greater than 15°, an eave purlin capping flashing may be required, see Section 3 for details.

### STRUCTURAL CAPPING FLASHING

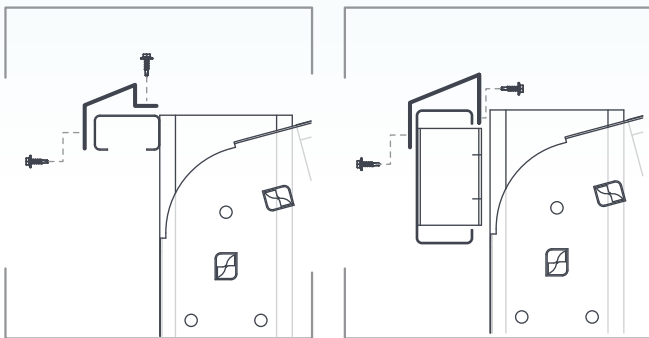


FIGURE 17.1

Fix the roof sheets, starting from one end of the Gable Roof Shed. Sheets should be laid into the prevailing wind.

Crest fix the sheets with 12x35mm self drilling screws or M6x50 timber/steel screws with neoprene washers. Use five screws per sheet at each end support, and three screws per sheet at each internal support.

Ensure the first sheet is square with the frame and that the roof sheets overhang into the gutter by approximately 50mm.

Turn the valley flute of every corrugated roof sheet upwards at the ridge/high end of the roof sheet. This will aid in water proofing the shed.

If it is necessary to walk over roof sheets, ensure that you walk over the purlins to avoid any damage. Wear flat, rubber soled shoes and walk flat footed, spreading your weight over as many corrugations as possible.

## ROOF SHEET PROFILES

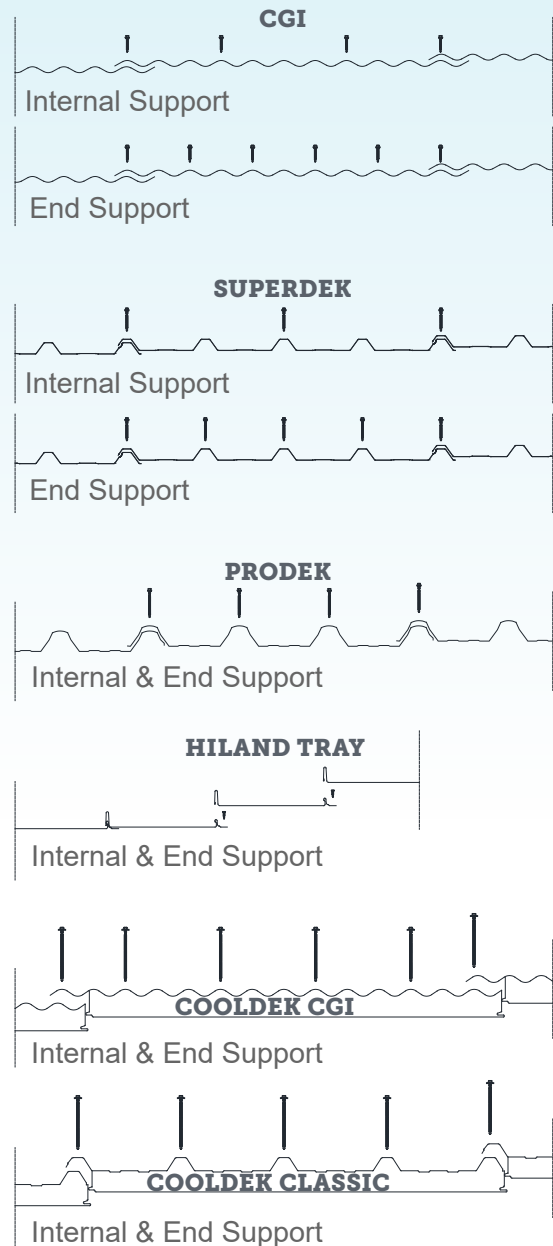


FIGURE 17.2

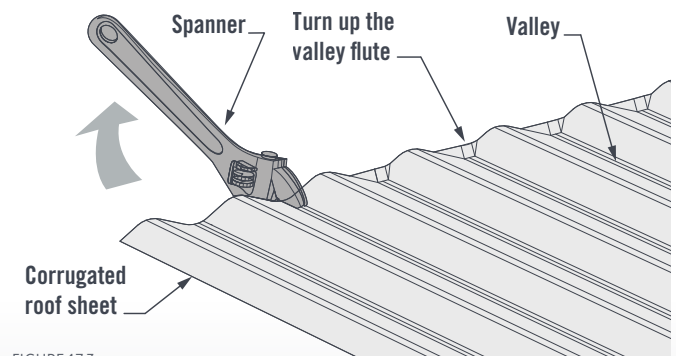


FIGURE 17.3

### HILAND TRAY ROOF SHEET INSTALLATION

**Note:** always check the documentation you receive with your shed for specific installation instructions as they may differ in some scenarios.

If installing Hiland Tray cladding on your Gable Roof Shed, ensure all framework is constructed before beginning cladding. It is also recommended that you measure out the crests of the Hiland Tray sheets on your shed before fastening them to ensure equal spacing of all sheets, and correct fitment of the final double overlap sheet.

### HILAND TRAY EAVE FLASHINGS

If Installing Hiland Tray on the roof, additional Purlin Capping Flashings will be required on the eave purlins to ensure a flat mounting surface for the roof sheets. Screw fix the capping flashing to eave purlin before installing the cladding.

Before installing the roof sheets, fix the supplied Gutter Attachment flashing to the top of the Eave Capping flashing.

Note: the gutters should be installed before the roof sheets, refer to Section 15/16.

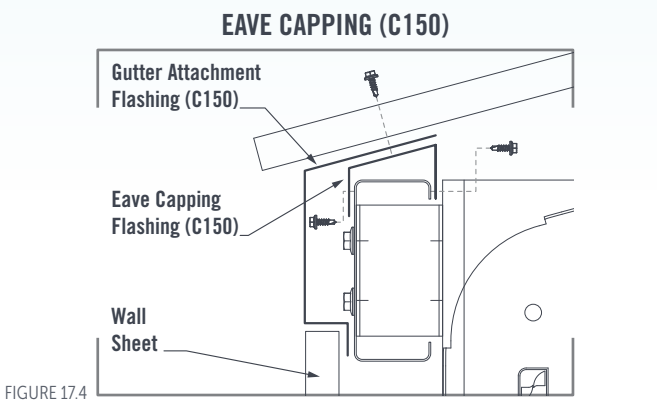


FIGURE 17.4

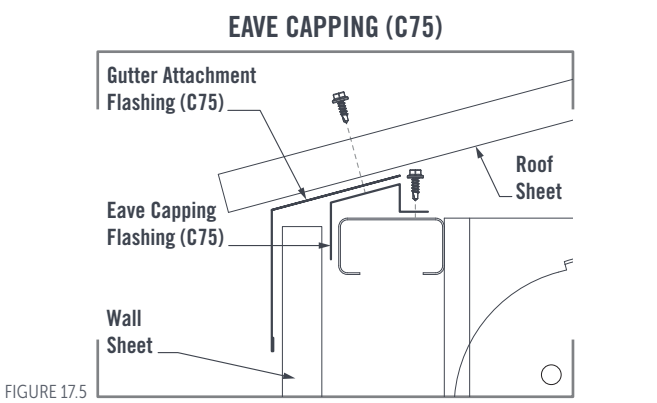


FIGURE 17.5

The supplied Barge Caps should also be fixed at the Gable Ends through the top and front faces of the Raking Channel. When installed, the Barge Caps should cover the top of the wall sheets. The barge caps must be installed before the roof sheets.

Fix the Ridge Support flashing on top of the highest roof purlins. The ridge support may require trimming to avoid interference with the barge caps.

Once the flashings are installed, the roof sheets should be installed following the same process as the wall sheets, starting at one end of the shed and working across. The overlap of the first sheet will cap over the crest of the Barge Cap.

The next sheet overlap will clip onto the underlap of the first Hiland Tray sheet, again securing the nailstrip side with Wafer Head screws, see Figure 106. Repeat this process for remaining sheets, then cap the underlap of the final sheet and opposite barge flashing with a supplied "Double Overlap" sheet.

Take care to ensure that all sheets and flashings are aligned correctly - when installed correctly, the crests of the roof sheets should align with the wall sheets.

The Ridge Cap can then be installed capping the roof sheets, fixing with 10x16 coloured screws through the Ridge Support Flashing.

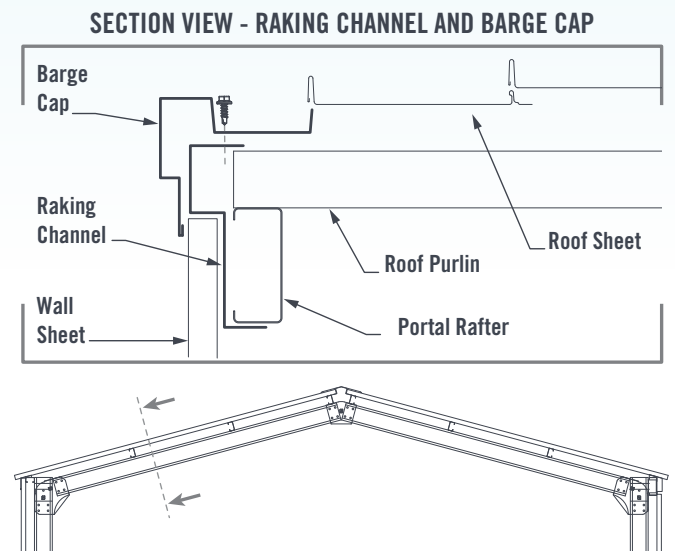


FIGURE 17.6

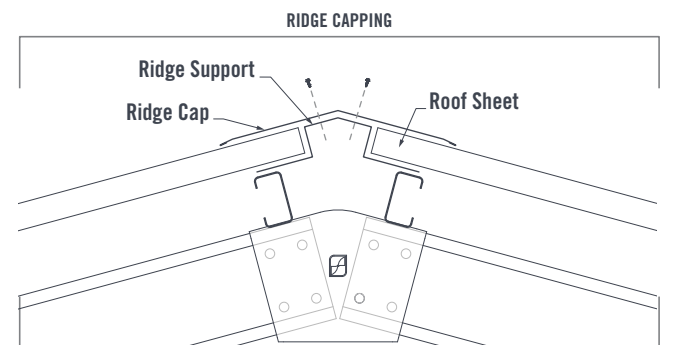


FIGURE 17.7

It's not recommended to walk on Hiland Tray roof cladding. If it is unavoidable however, ensure that you walk over the purlins to avoid any damage. Wear flat, rubber soled shoes and take extreme care & caution.

## COOLDEK ROOF SHEETS

There are two different Cooldek Sheet profiles available: Cooldek Classic and Cooldek CGI. The installation process is the same for both types of Cooldek sheet.

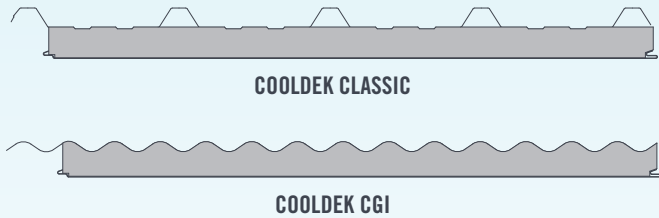


FIGURE 17.8

Note, Cooldek sheets are supplied with the top sheet 65mm longer than the insulating foam core and under sheet to allow for the cutback flashing and gutter to be attached. Ensure this end of the sheet is installed at the Eave of the shed.

Lay the Cooldek sheets one at a time, starting from one end of the shed. Note that the skin on the underside of the Cooldek sheet should extend 15mm beyond the edge of the Eave Purlin, see Figure 100. Once the first sheet is in position, lay the next sheet over the previous sheet's side lap and ensure that the slip joint of the two sheets has engaged.

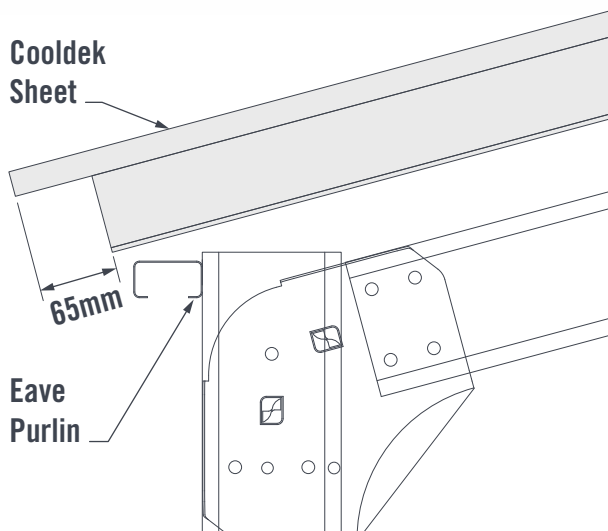


FIGURE 17.9

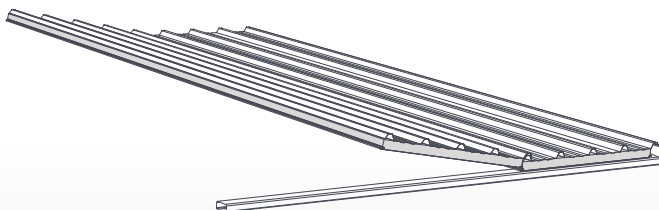


FIGURE 17.10

Cooldek CGI sheets should be fixed at every second crest with 14x110 Screws, Cooldek Classic should be fixed at every crest with 14x125 screws. Use cyclonic washer plates and neoprene washer in all crest fixings.

Once one side of the shed has all sheets installed, rivet the Cooldek receiving channels together. Slot the receiving channel assembly over the ridge of the installed sheets.

Install the Cooldek sheets on the other side of the roof, repeating the same process installing of them one by one, and pressing them into the receiving channel as you go.

Once all sheets are fixed, install the Cooldek Cutback flashing on either side of the shed, rivet the bottom of the cutback flashing to the bottom of the cooldek metal skin.. Fix the ridge cap with 10x16 screws through the Cooldek receiving channel.

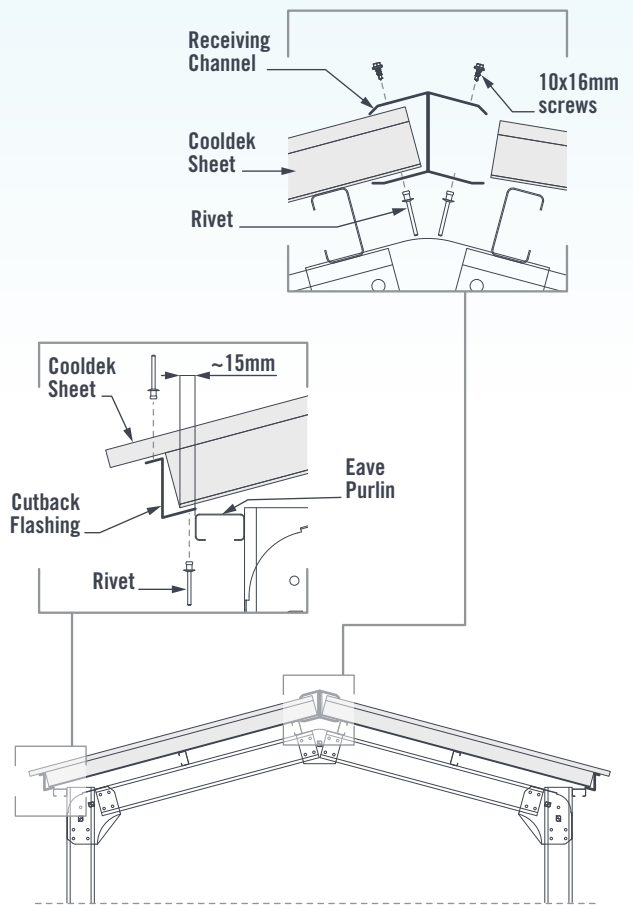


FIGURE 17.11

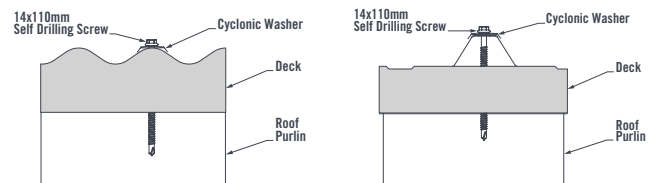


FIGURE 17.12



FIGURE 17.13

## 18. PERSONAL ACCESS DOOR

### PA DOOR - SIDE WALL

Note: This page includes details for side wall PA doors, on sheds with superdek cladding and standard heights (2.4m, 2.7m, 3m). If your shed or door is different to this, some details may differ.

Note: if installing a flat metal skin door, please refer to the details on the following page.

If you are installing a standard PA door (815mm wide), leave an 835mm gap between the wall sheets. Fix the wall sheets on either side of the proposed door location. It may be necessary to rotate one of the wall sheets so the under-lap is aligned with the door opening on both sides.

Once the wall sheets have been fixed, cut the middle and bottom wall girts with a hacksaw. Do not cut the top wall girt. Slide the door mullions into position so they cap the middle and bottom wall girts. Notch and fix the door mullions to the top girt with one 10x16mm self drilling screw and one rivet.

Note: Do not use the PA door lintel as a mullion spacing template. The PA door lintel is supplied longer to allow for on site tolerance and must be cut to fit between the door mullions.

Position and fix the door lintel to the door mullions with two rivets. The door lintel should finish 2250mm from the bottom of the wall sheets/FFL.

Pan fix a wall sheet to the PA door frame with 10x16mm screws. Fix the PA door side flashing with rivets at 600mm centres.

Determine which way the door will swing. The PA door frame will be provided with two 100x75mm hinges. Fix the hinges to the door mullion with 10x16mm wafer head screws.

If PA Door sheets require cutting, the excess sheeting can be fixed above the PA Door in conjunction with a PA Door gutter flashing. Alternatively, if a PA Door header flashing is provided, rivet the PA Door header flashing to the door mullions to flash the area above the door opening.

For sheds pinned-on-concrete, mullions are to be fixed to the slab using a 45mm angle bracket with an M10x20 hex head bolt and M8 masonry anchor.

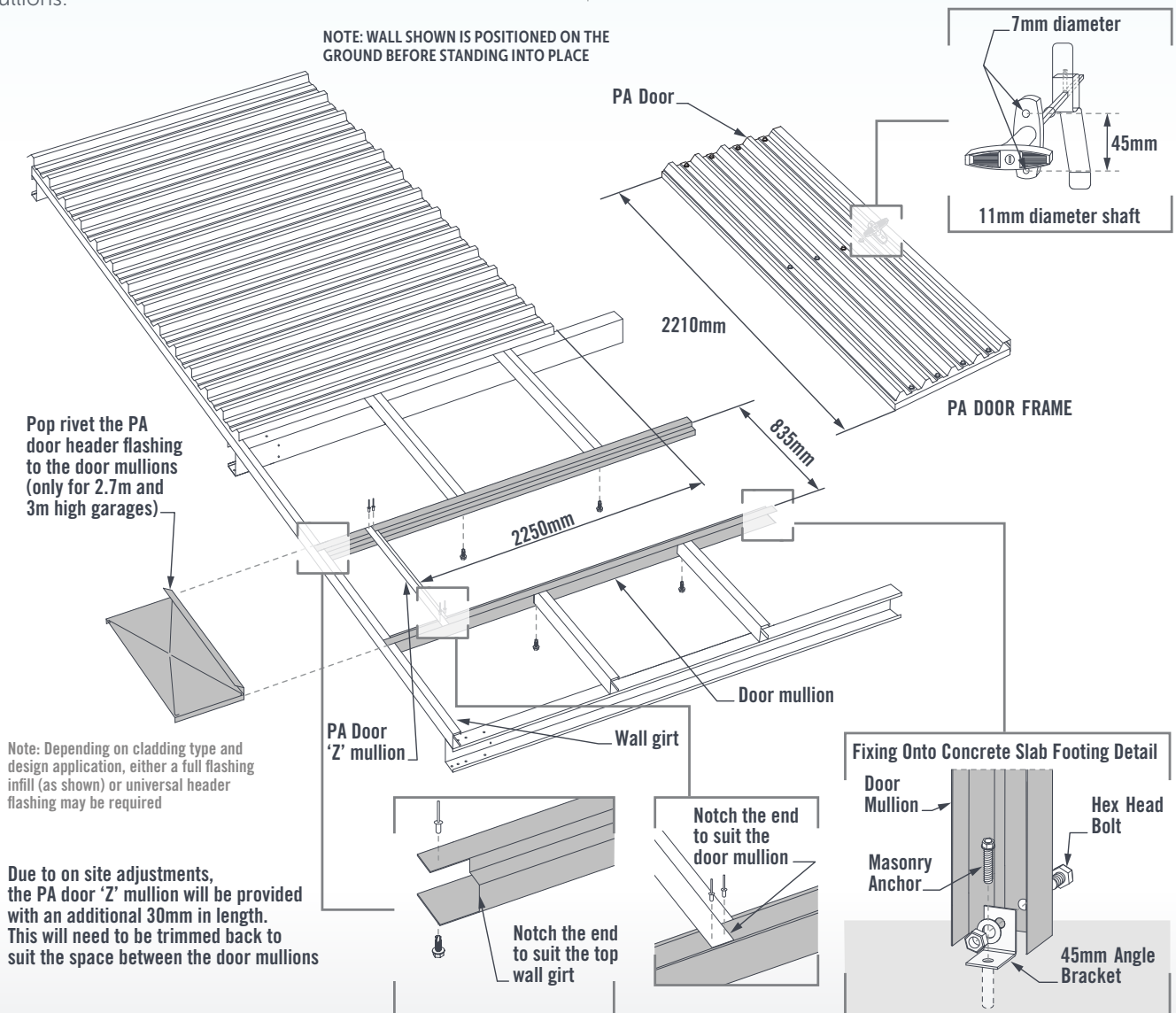


FIGURE 18.1

## PERSONAL ACCESS DOOR

### PA DOOR - END WALL

For sheds walls greater than 2.4m high, the PA Door mullions will be fixed to the next wall girt above the PA door header.

If the PA Door is being installed in a shed wall less than 2.4m high, the mullions will be fixed to the rafter.

End wall sheets will not be rotated, so sheets will need to be trimmed to allow for the PA Door opening - see Figure 18.2. When cutting the second sheet try to cut along the pan of the sheet to ensure a clean flat edge with no gaps. PA Door angle trim flashings will be supplied to flash the edge of the cut sheets where necessary.

A PA Door gable end header flashing will be provided and may require cutting to suit the location of crests on the wall sheets. This flashing will cap the bottom of the cut header sheets and act as a gutter above the door opening.

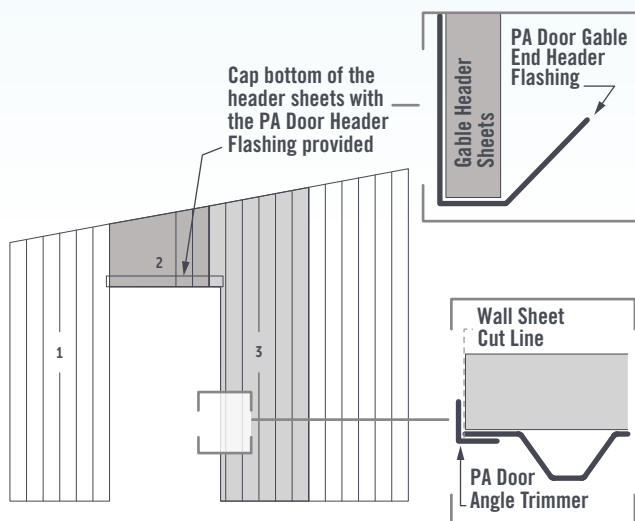


FIGURE 18.2

Note: Where PA door mullion aligns with superdek pan, use angle trim to cover cut edge of wall sheet.

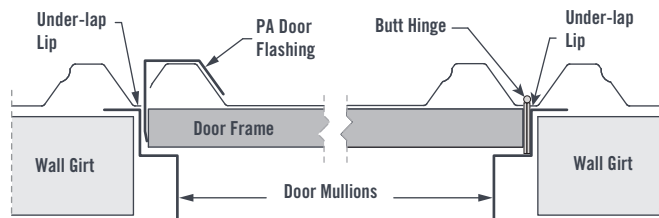


FIGURE 18.3

### DOUBLE PA DOOR

If installing a double PA door, installation of the PA door mullions follows the same process as for single PA doors. Allow a gap of 1660mm when cutting the wall girts.

Similar to End Wall PA door installation, the wall sheets around the PA door will not be rotated and will need to be trimmed to allow for the double PA Door opening. A PA header flashing will be provided to cap the sheets above the PA door.

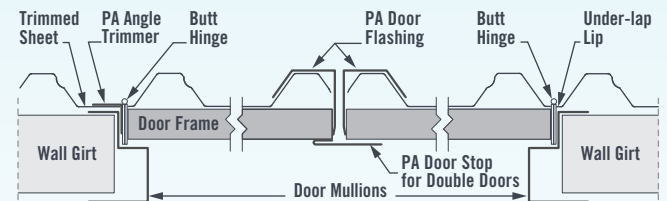


FIGURE 18.4

### FLAT METAL SKIN PA DOOR

If installing a Flat Metal Skin PA Door (820mm wide), cut an 850mm gap in the wall girts. Slide the door mullions into position so they cap the middle and bottom wall girts. Notch and fix the door mullions to the top girt with one 10x16mm self drilling screw and one rivet.

Similar to Gable End PA Door installation, the wall sheets around the PA door will not be rotated and will need to be trimmed to allow for the door opening. A PA Header flashing will be provided to cap the bottom of the cut header sheets. The flange of the door frame will cover the trimmed wall sheets.

The Flat Metal Skin PA Door will be provided pre-assembled. Once the wall sheets are trimmed and secured, slide the door assembly into position and secure with 10x16mm self drilling screws.

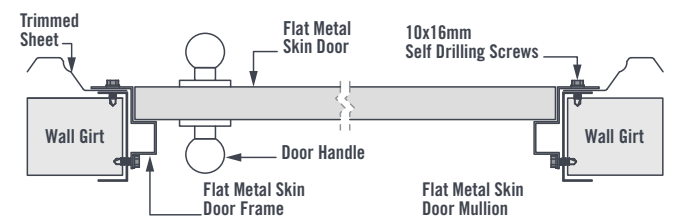
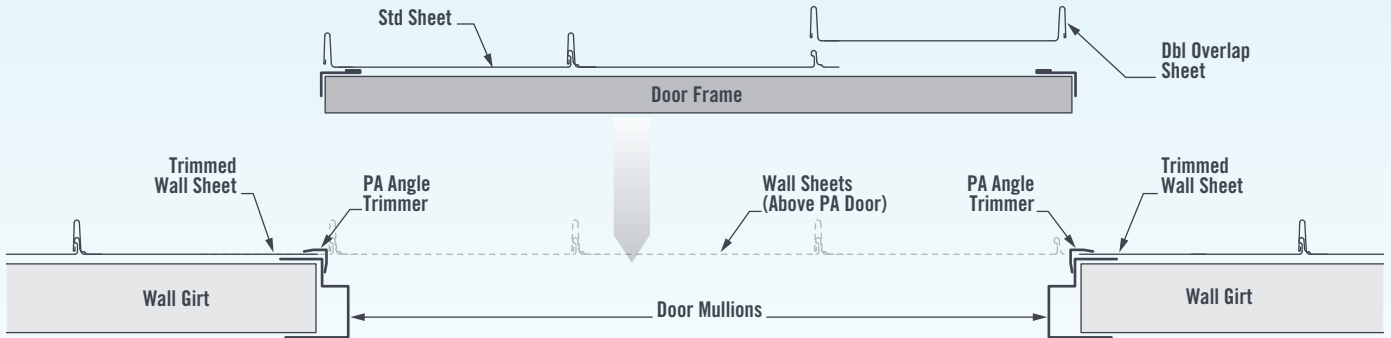


FIGURE 18.5

### HILAND TRAY PA DOOR

On sheds with Hiland Tray cladding, ensure mullions are positioned so that the crests on the PA door sheets align with the crests on the wall sheets. Line up the outside door sheets with the edge of the door frame, overlapping the door frame corner flashings.

Similar to Gable End PA doors, the wall sheets will need to be trimmed around the opening. Ensure PA door is positioned so that the Hiland Tray sheets can be neatly cut along the pan, and cap the trimmed wall sheets with PA angle trim flashings.



**NOTE:** for hiland tray sheds, please refer to job-specific elevation drawings for more information regarding door positioning and flashing.

FIGURE 18.6

## 19. WINDOWS

**Note: Window install method will differ for Hiland Tray cladding - please ensure you follow the correct method for your cladding type.**

### WINDOWS: SUPERDEK, CGI, INTERLOCK

If installing a window, please note that the louvred window requires one trimmed sheet and the sliding window requires two trimmed sheets (on sheds clad with Superdek).

During the process of fixing the wall sheets to the shed frame, determine the location of the window. Fix the wall sheets prior to installing the window, see Section 10/11 Building the Frame. The wall sheets will need to be trimmed to accommodate the window, allowing for the base of the window to be supported by and fixed into a wall girt.

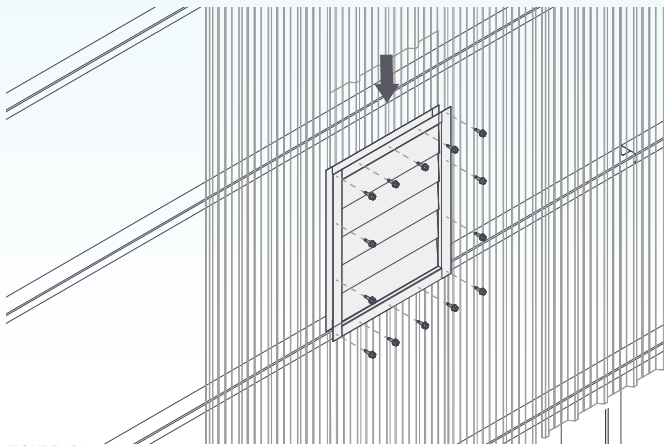


FIGURE 19.1

Place the remaining sheets loosely into position and check the window will fit the opening. Ensure the wall sheets either side of the window are positioned tightly about the window frame so no gaps occur. Correct spacing of the wall sheets is best achieved by ensuring the top edge of the sheets are aligned parallel with the top edge of the top wall girt. Place the pre-assembled window into the opening (ensuring it is in the correct orientation) and check for squareness before continuing to lay the remaining sheets.

Install the window frame to the crest of the wall sheets using colour 10x16mm self drilling screws supplied. Ensure the screws are evenly spaced around the remaining frame. Place a bead of silicone in each corner of the window to prevent water entry.

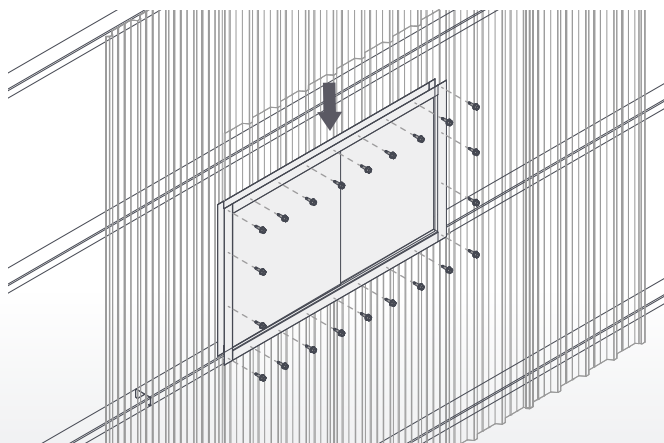


FIGURE 19.2

### WINDOWS: HILAND TRAY

If Hiland Tray cladding is used, it's recommended that the window is aligned with the outside of the shed's framework (not the outside of the cladding). The cladding will then run in front of the window's flanges, and header/angle trim flashings can be used to finish the edges of the Hiland Tray.

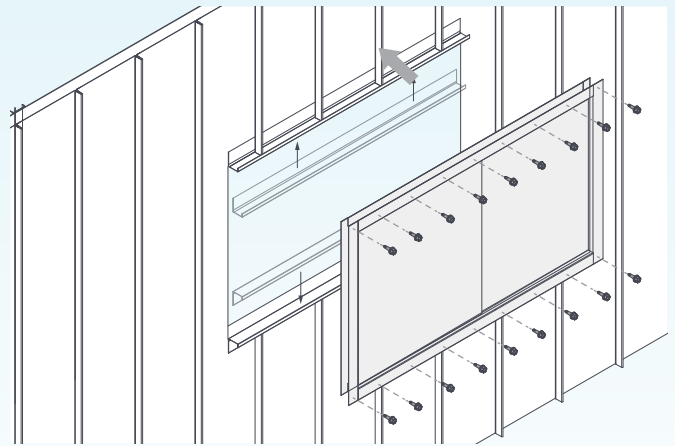


FIGURE 19.3

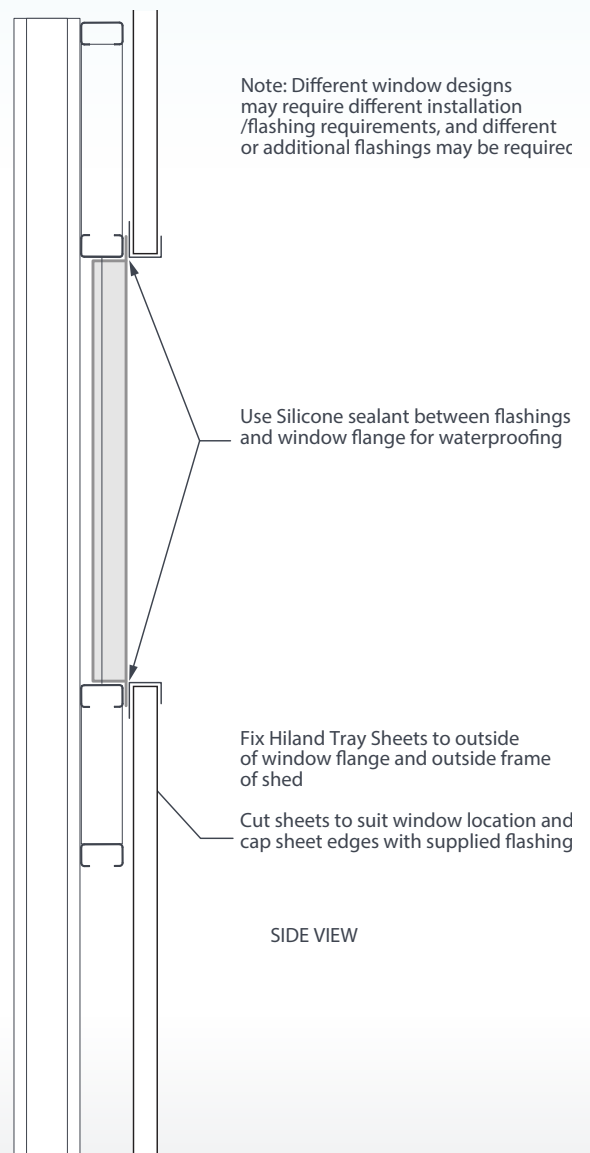


FIGURE 19.4

## 20. CLEAR OPENING - SIDE WALL

Note: If installing a Glass Sliding Door in the End Wall, the framework installation process is the same as for a Gable End Roller Door - refer to Section 23 for details.

### FRAMEWORK - SIDE WALL

It is recommended that the framework be assembled while building the wall panels on the ground. However, the door itself should be installed once all framework is assembled and upright.

Fix the structural header beam between the Portal Columns using supplied GP Brackets with two M12x30 flanged purlin bolts per leg, bolting either to the web of the column directly, or through the open web. Ensure the open web of the header beam faces down to avoid any interference between the sliding door and bolts.

Alternatively, angle connectors with clamp plates may be supplied in place of general purpose brackets.

Measure out the gap between the columns, allowing up to 10mm extra either side for the door opening. Note, do not use the header beam as a template for the door width/column position. Fix the web of the sliding door columns directly to the flange of the header beam with two M12x30 flanged purlin bolts.

Note: These two holes are to be drilled on site through the Sliding Door Column and Structural Header Beam.

Secure the header girt to each sliding door column using two header beam brackets with two plain 12x20 self drilling screws in each flange of the bracket.

Fix the wall girts to the columns with girt brackets using two 12x20 self drilling screws per bracket leg.

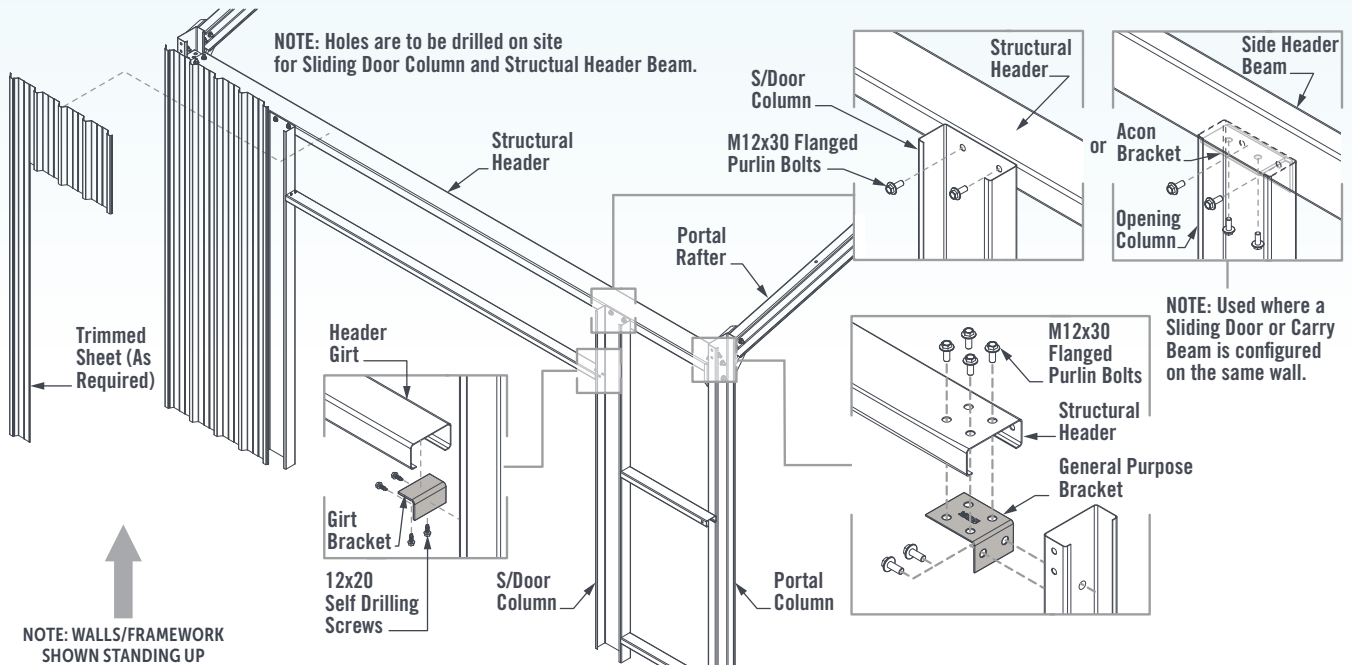


FIGURE 20.1

### DOOR INSTALL

The wall sheets either side of the opening will need to be trimmed as close to the column edge as possible. A header flashing is supplied to cap the bottom of the sheets sitting above the door, and column/wall flashings are supplied to cover the sides of the openings.

Alternatively, the flange of the glass sliding door unit can be butted up directly against Superdek sheets on the sides, take care when positioning the door opening to ensure that the flanges are located on the Superdek pan.

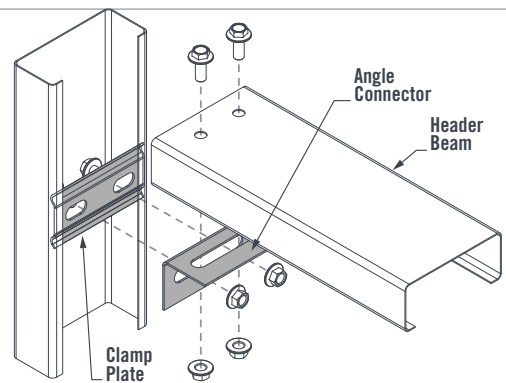


FIGURE 20.2

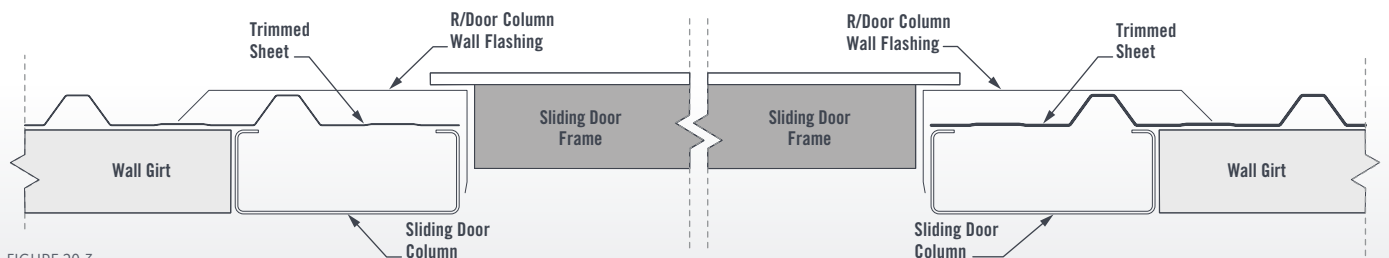


FIGURE 20.3

## 21. ROLLER DOOR - SIDE WALL TYPE 9 - SINGLE ROLLER DOOR

The roller door columns can be installed while building the wall panels on the ground, column flashings can be installed when the completed wall frames are standing.

Bolt both the left and right side roller door columns to the respective portal frame columns. Secure the header beam to each roller door column using the supplied header beam brackets.

Use two plain 12x20mm self drilling screws in each leg of the header beam brackets. The bottom face of the header beam should measure 300mm from the top of the top girt for 15° gable sheds. This will allow a fixing point for the infill sheets above the door.

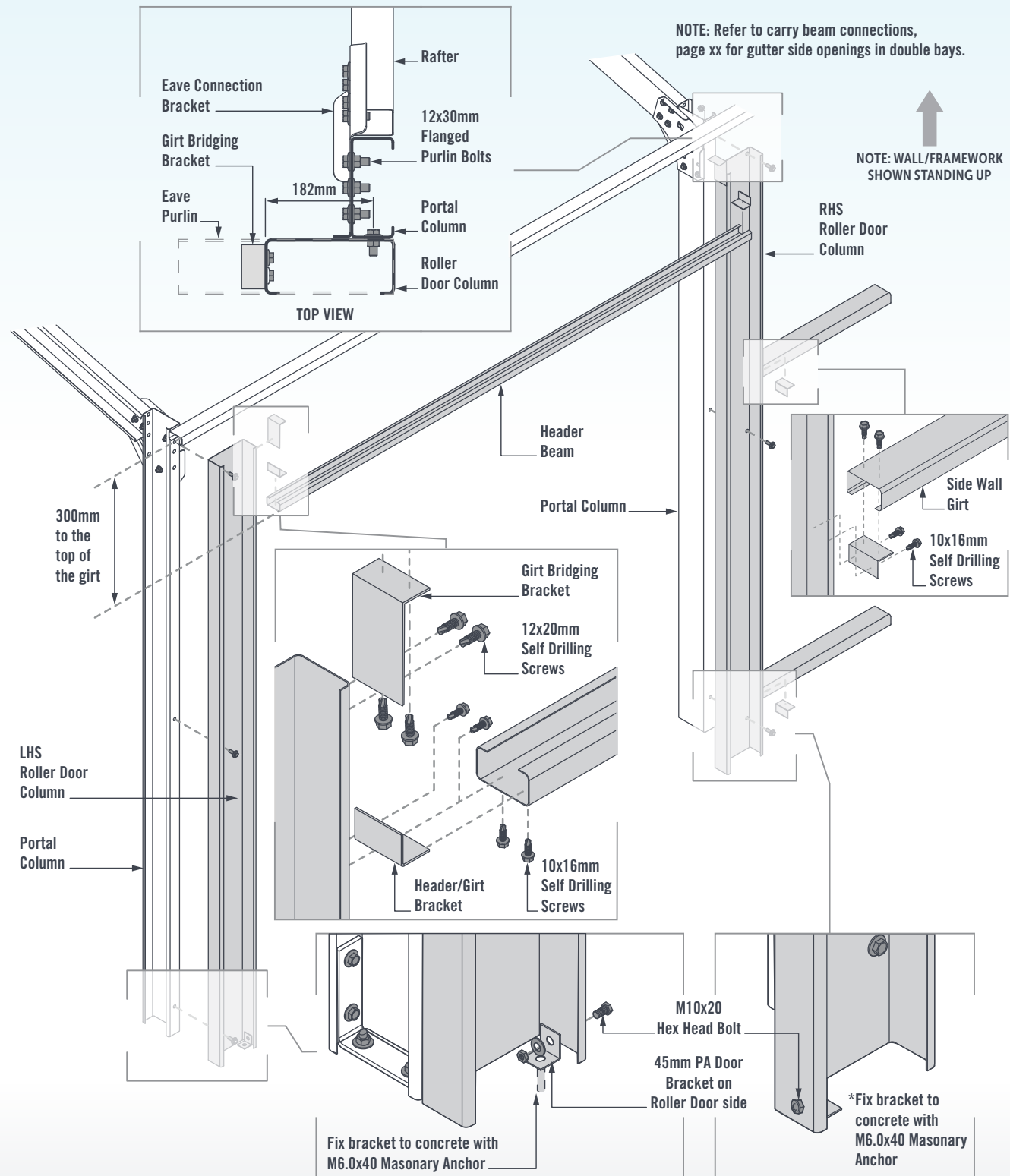


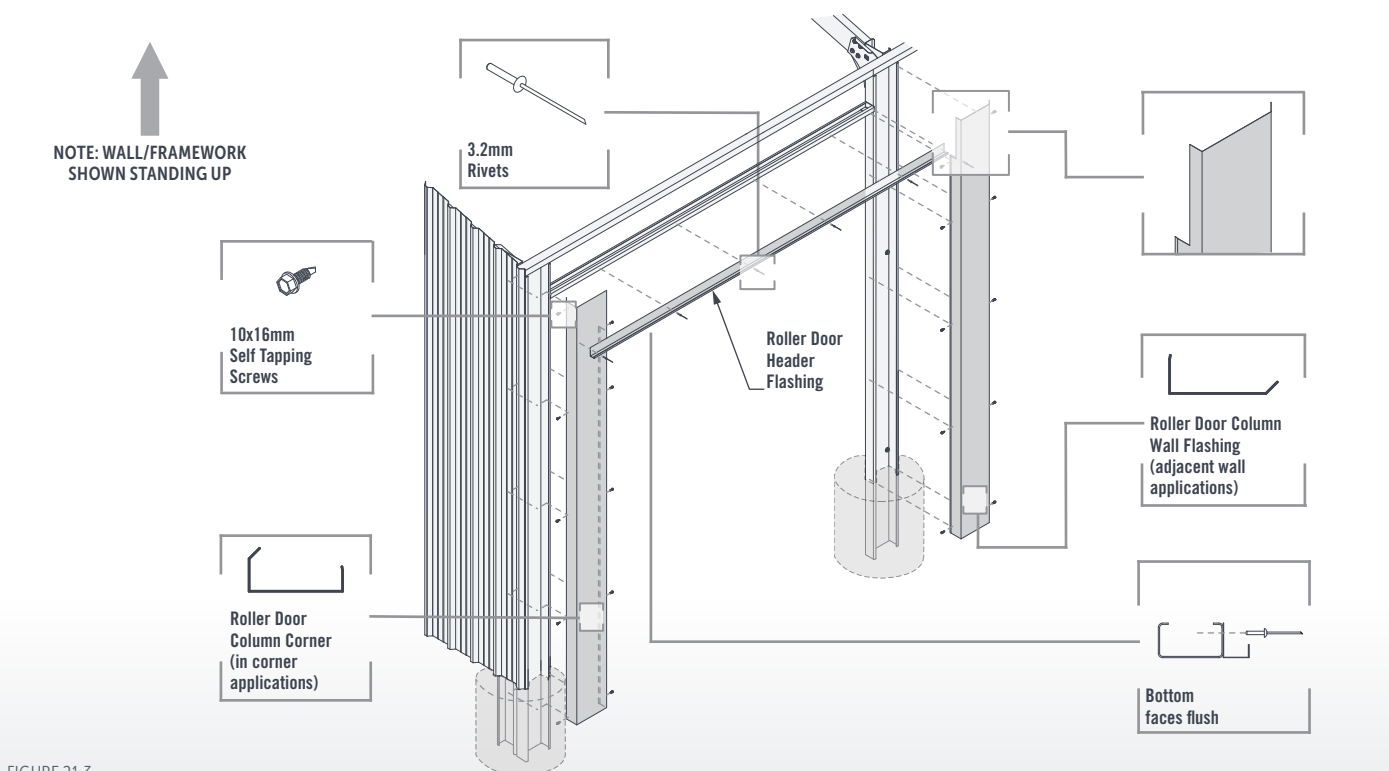
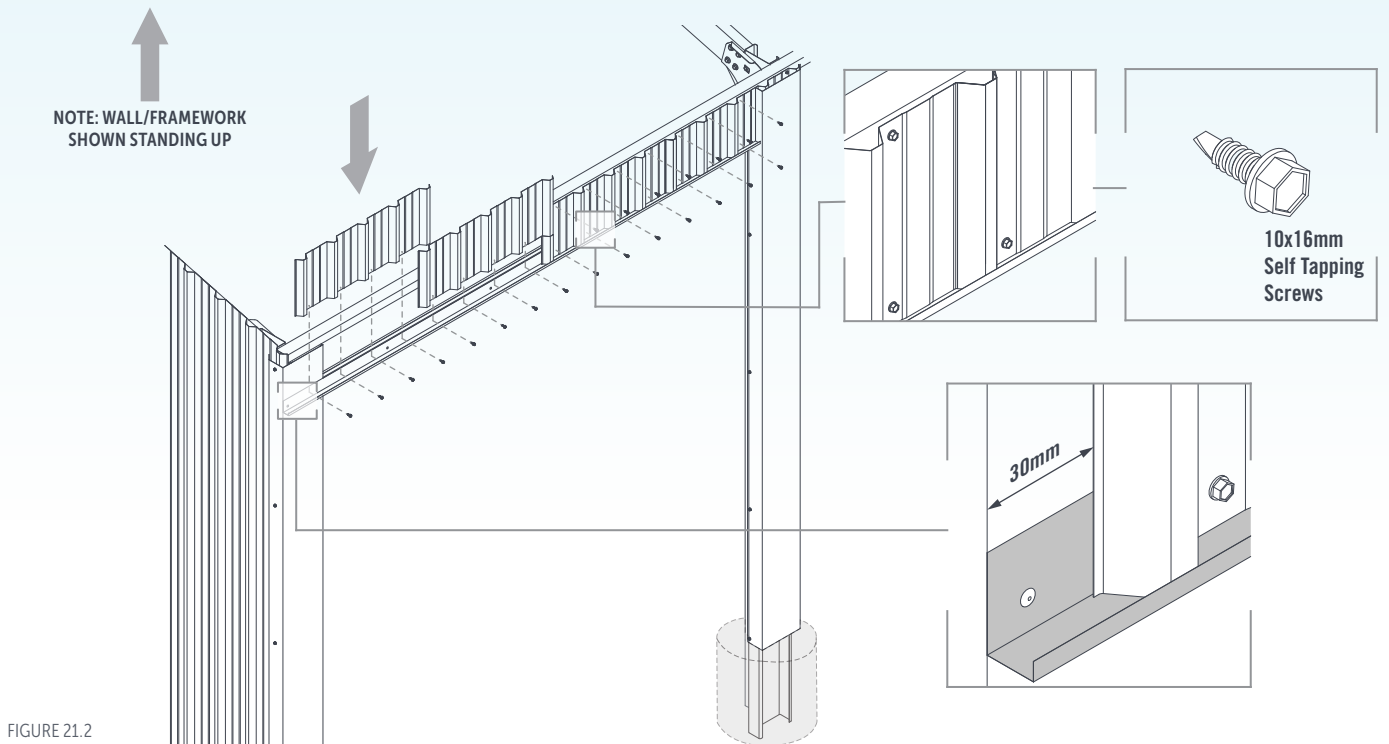
FIGURE 21.1

Slide the infill sheets into the header flashing and fix through to the header beam and top girt using coloured 10x16mm self drilling screws in every pan.

Position the roller door column flashings over the roller door columns, and in corner applications over the ends of the end wall sheets.

Fasten the two roller door column flashings (corner or wall depending on application) to your roller door columns using coloured 10x16mm self drilling screws at 600mm centres.

In applications where roller door column wall flashings are used, the flashing will need to be notched, see Figure 21.3. Rivet the roller door header flashing into place on the header beam using 3.2mm rivets at 600mm centres so that both bottom faces are flush.



## TYPE 10, 11 AND 12 - MULTIPLE ROLLER DOORS

Start by bolting the roller door columns (C200 & Intermediate) to the respective portal frame columns. Secure the header beams to the roller door columns using two header beam brackets per header beam. Use two plain 12x20mm self drilling screws in each leg of the header beam brackets. The bottom face of the header beams should measure 300mm from the top of the top girt for 15° gable sheds - this provides a fixing point for the infill sheets.

Position the roller door column flashings over the roller door columns and in corner applications over the ends of the gable end sheets. Fasten the roller door column flashings (corner, intermediate or wall depending on application) to

your roller door columns using coloured 10x16mm self drilling screws at 600mm centres. Flashings that interfere with header beams will require notching.

Rivet the roller door header flashing into place on the header beam using 3.2mm rivets at 600mm centres so that both bottom faces are flush, see Figure 51. Slide the infill sheets into the header flashing and fix through to the header beam and top girt using coloured 10x16mm self drilling screws in every pan.

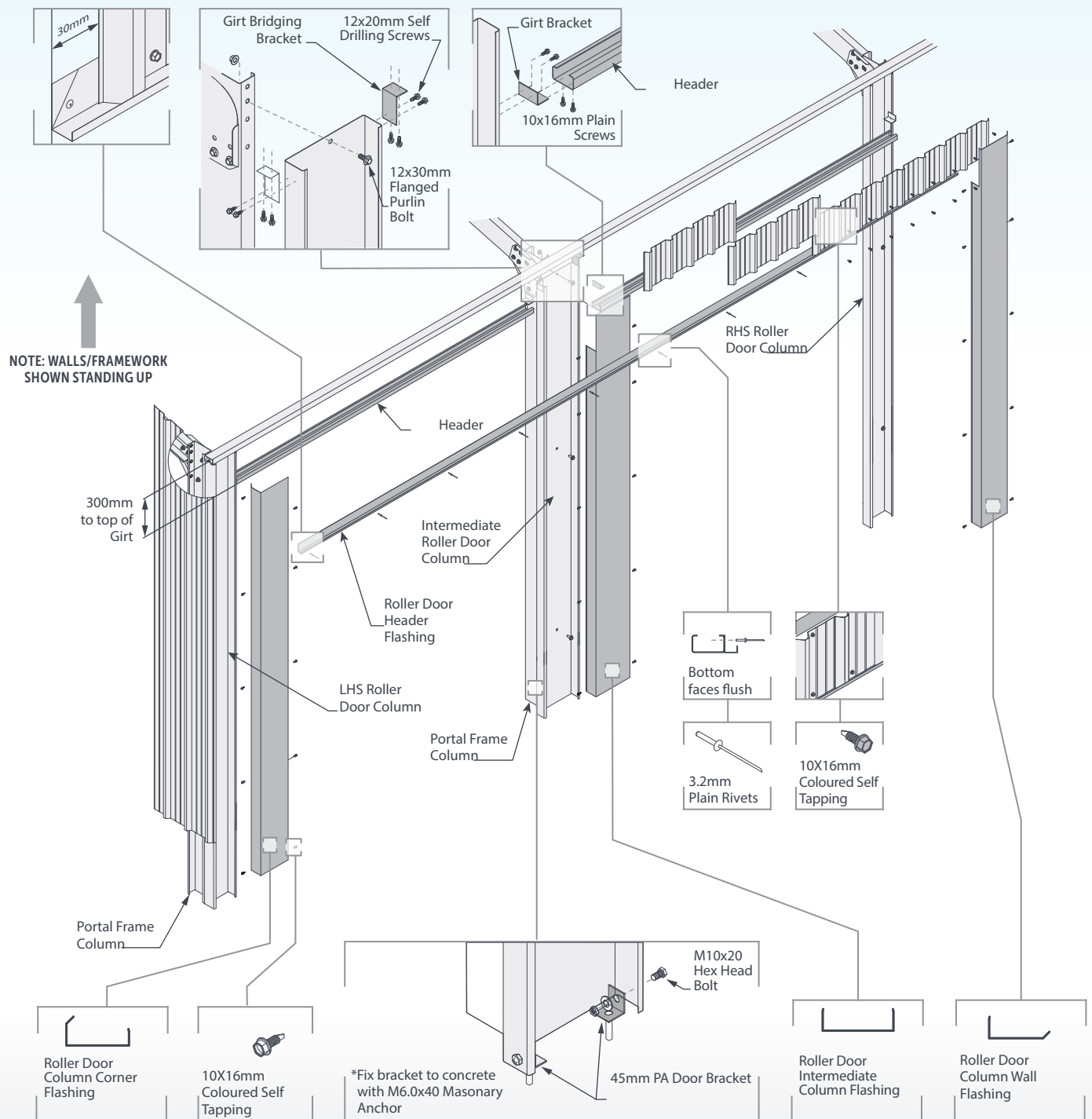


FIGURE 21.4

## 22. SLIDING DOOR INSTALLATION - SIDE WALL

The Sliding Door Frame is supplied in separate components, and needs to be assembled on site. It is recommended that the sliding door frame is assembled and clad before installing on the shed.

### SLIDING DOOR FRAME ASSEMBLY

On each door frame, mark and drill pilot holes where the spigots are located. On the top and middle horizontal members drill pilot holes for 12x20 self drilling screws on the top and bottom faces of the members at each open end. On the bottom horizontal member drill pilot holes on the top for 12x20 self drilling screws and on the front for 10x16 wafer head screws at each open end.

These pilot holes are to be located centrally along the horizontal members, spaced 50mm and 100mm back from each open end of the frame. Mark each length of spigot at 150mm. Insert a spigot into each open section of frame on door half 'A' up to the 150mm mark.

At the top and middle horizontal members fix the spigot with four 12x20 self drilling screws through the pre-drilled holes.

At the bottom horizontal member fix the spigot with two 12x20 self drilling screws through the top pre-drilled holes, and two 10x16 wafer head screws through the front pre-drilled holes.

Slide door half 'B' onto the three spigots and fix as specified for door half 'A'. Clamp the Angle Track to the bottom of the assembled door frame, ensuring the ends of the angle track align with the ends of the door frame.

Drill pilot holes along the angle track, through the face located against the bottom horizontal member. The first pilot hole is to be spaced 100mm from each end of the angle track and all following pilot holes moving towards the centre of the angle track at maximum 400mm centres. If a pilot hole is located over the bottom spigot, move the pilot hole 30mm offset from the end of the spigot.

With the angle track clamped to the bottom horizontal member, fix a 10x16 wafer head screw through every pilot hole.

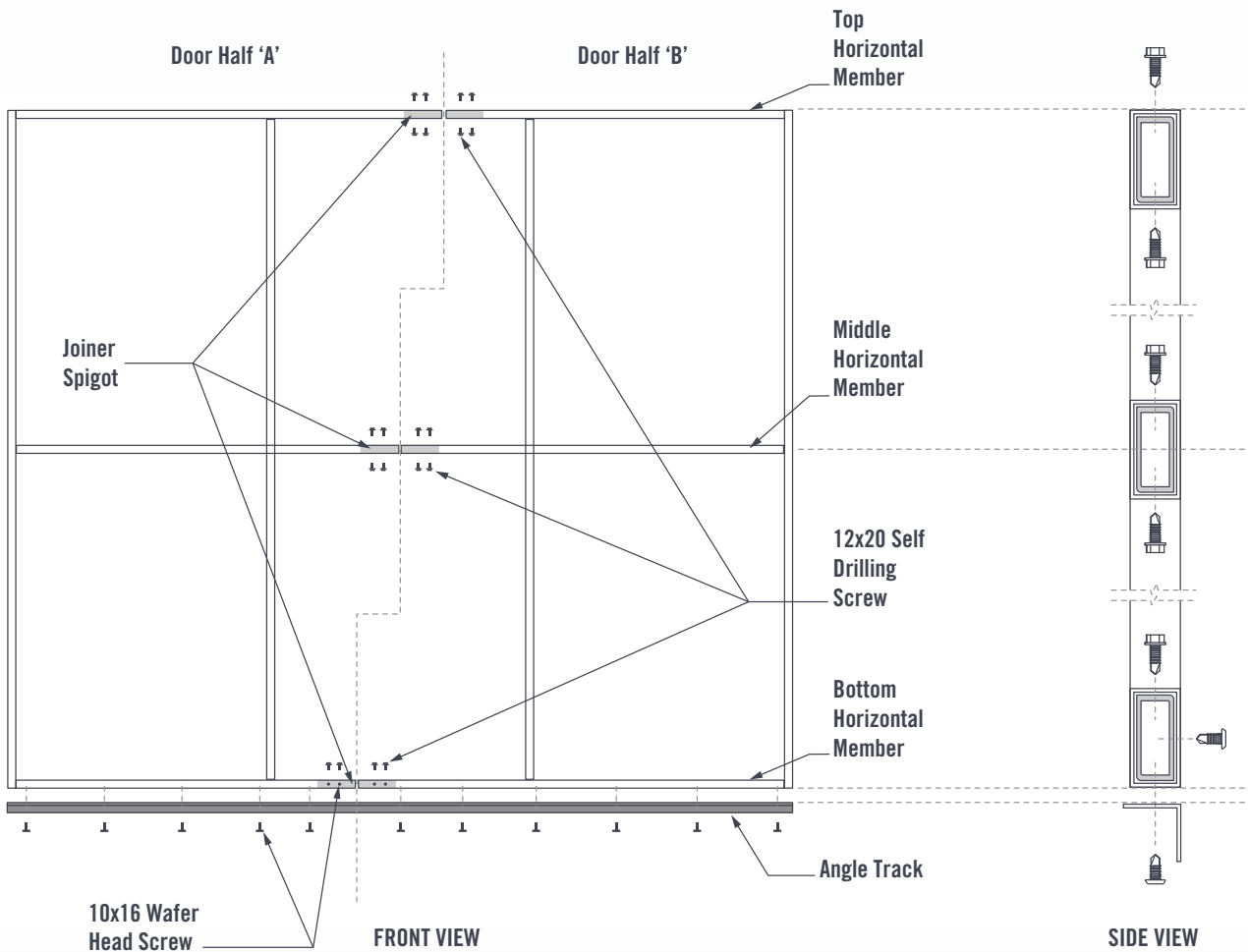


FIGURE 22.1

## SLIDING DOOR FRAME & SHEETS

Full sheets are provided for the sliding door frames. Lay all the sheets on the sliding door frame and check coverage/layout before fixing the sheets to the frame.

The sheets located at each end of the sliding door frame must be oriented so the underlap edge is in line with the outside edge of the frame.

Ensure the sheets are aligned with the bottom face of the bottom horizontal member.

**Note: The sheets must allow clearance for the angle track to fit in the guide blocks and slide freely.**

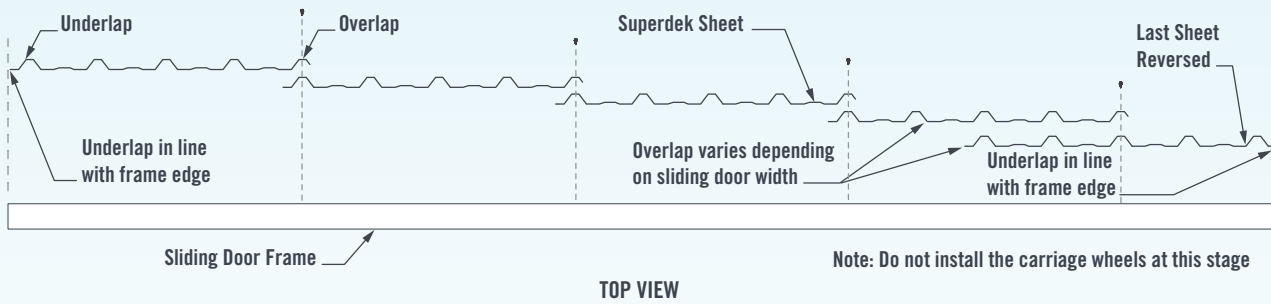


FIGURE 22.2

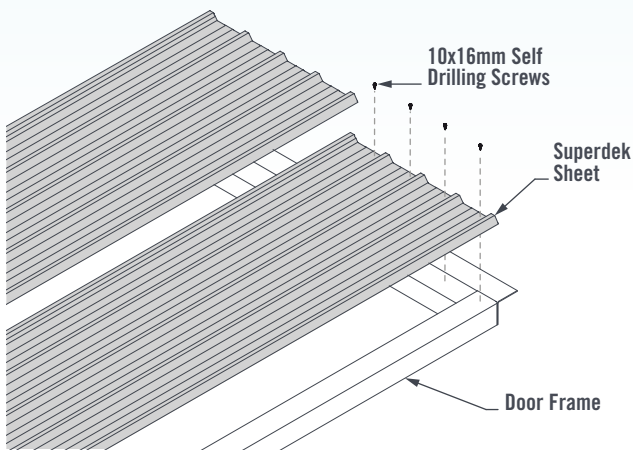


FIGURE 62

Drill a 10mm hole through the top horizontal member of the door frame approximately 300mm in from both sides. Lift the door and stand it directly under the door track. Insert the 8mm carriage pins through the 10mm holes and secure with a nut. Adjust the height of the door accordingly. Ensure the door slides before footings are poured.

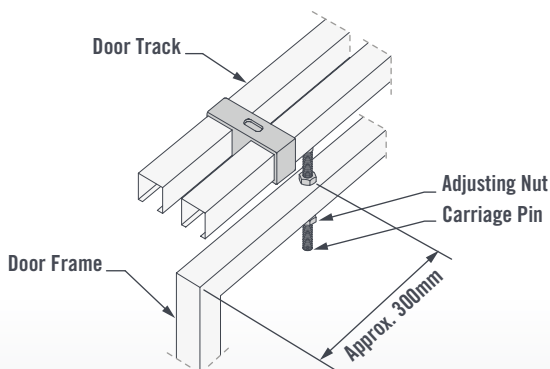


FIGURE 22.3

Once the footings have been poured, bolt the floor guideblocks to a concrete base with four M8x65mm masonry anchors. The central floor guide blocks are located side by side.

Please refer to the Manufacturer's installation details for the sliding door lock assembly instructions.

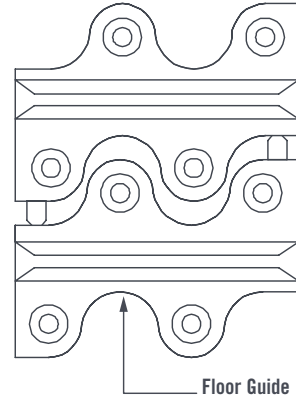


FIGURE 22.4

**FRAMEWORK**

It is recommended that the framework is constructed together with the side wall assembly - please read this section of the guide in conjunction with Section 10.

**Note: Due to on-site adjustments and variances in bay spacings, header beams will be supplied un-punched.**

Fix the header beam brackets to the columns using M12x30 flanged purlin bolts. Place the 150mm header beam over the header beam brackets so that the top of the header beam is in line with the top of the column.

From the inside of the header beam mark the hole locations and drill 14mm holes where required. Bolt the header beam to the header beam brackets, using M12x30 flanged purlin bolts.

Place the wall girts across the columns, leaving an opening between the columns where the sliding doors will be positioned. Match the pre-drilled holes and fix each girt to each column with M12x30 fascia bolts.

Place the filler column on top of the column at the end bay that will have a sliding door. Fasten the columns together using M12x30 flanged bolts and nuts.

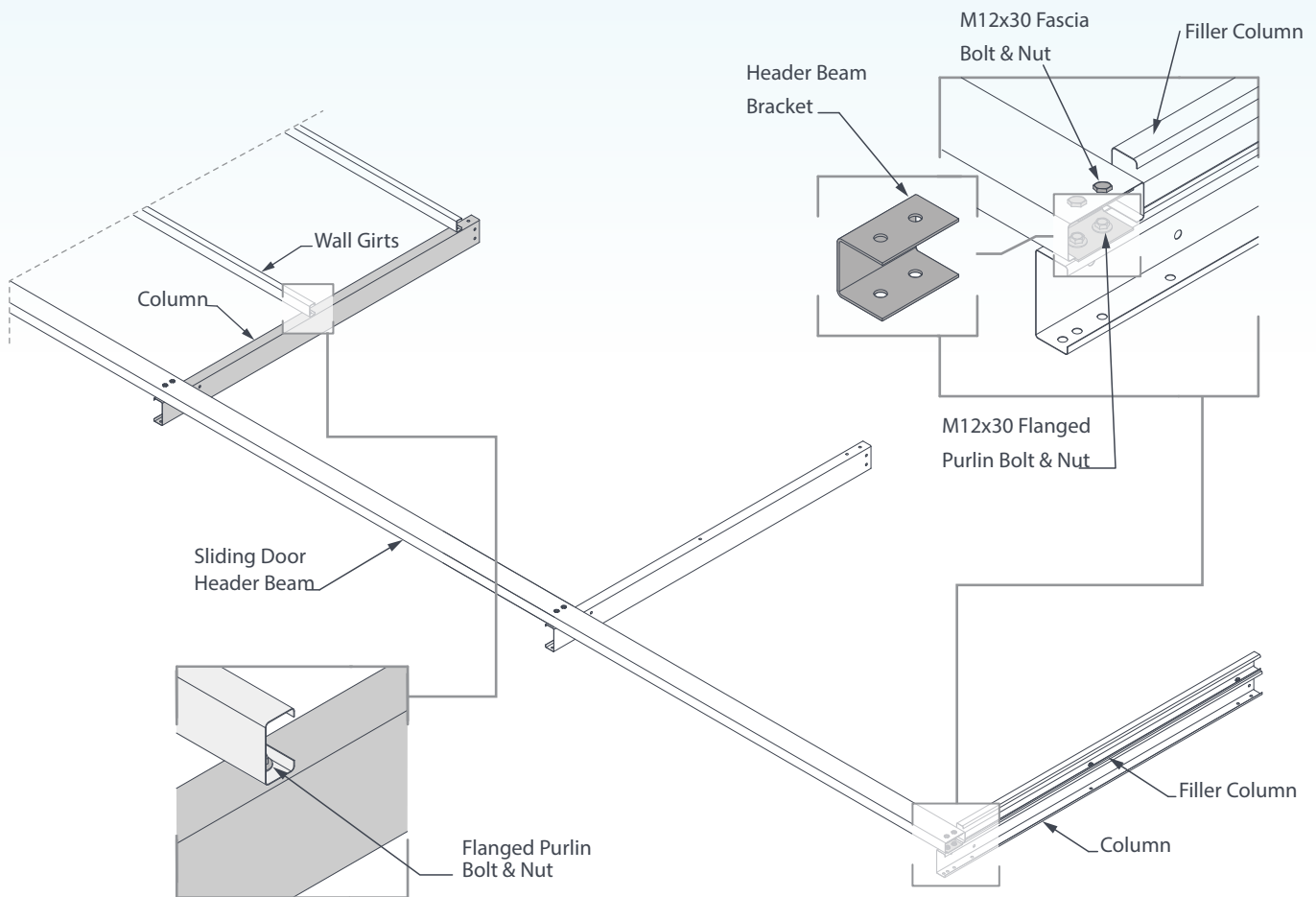


FIGURE 22.5

Where the sliding door header beam is to be joined, a header beam joiner is required. The connection of the header beams must be bolted over the centre of the column.

Attach the joining plate to the header beams with six M12x30mm fascia bolts (the two central bolts will be shared with the header beam bracket).

Use four wafer head screws to join the top face of the header beam joiner to the header beams.

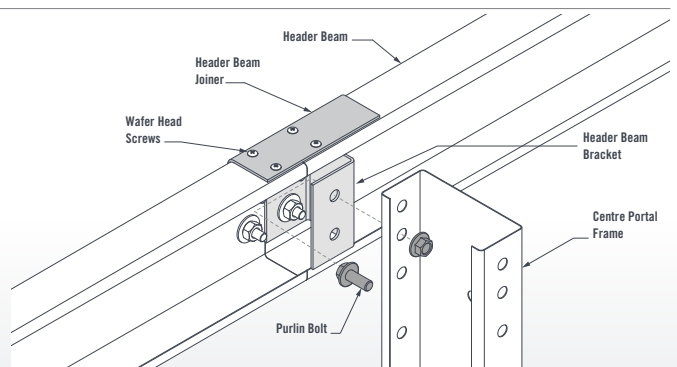


FIGURE 22.6

### SINGLE SLIDING DOORS

Use an M8x12mm counter sunk bolt to fix the support bracket to the track bracket.

Slide the sliding door track through the brackets and space at 800mm centres. Slide two nylon 4 wheel carriages into the end of each sliding door track. Fix the sliding door support brackets to the header beam with M10x16mm hex head bolts at 800mm centres.

Position the support bracket so the top face of the bracket is flush with the bottom of the header beam.

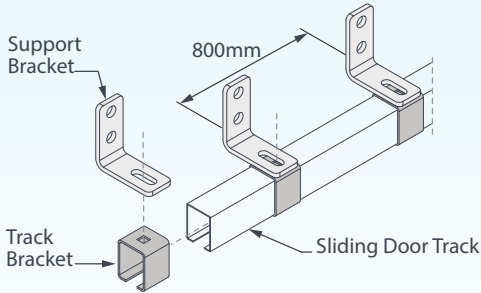


FIGURE 22.7 - SINGLE SUPPORT BRACKET

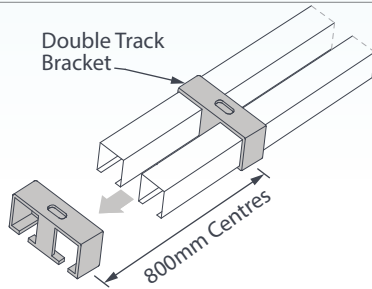


FIGURE 22.8 - DOUBLE SUPPORT BRACKET

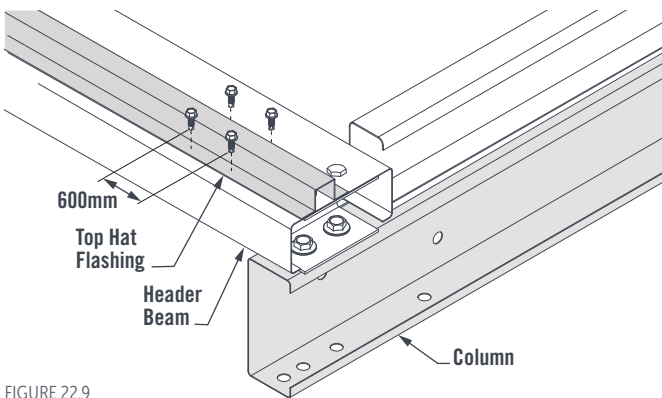


FIGURE 22.9

A "top hat" shaped flashing has been supplied to pack the area above the sliding door. Place the flashing over the top of the flanged purlin bolt heads, and fasten to the header beam at 600mm centres with 10x16mm self drilling screws.

Fix the header beam packer flashing to the "top hat" flashing and header beam with rivets at approximately 300mm centres.

Rivet the sliding door flashing to the packer flashing at 300mm centres. Align the sliding door flashing with the bottom face of the header beam packer flashing.

Fix the gutter brackets to the header beam packer flashing at approximately 1000mm centres with rivets. Once the gutter brackets have been installed, roll the gutter bead onto the gutter bracket and clip the back of the gutter into position.

Stand the wall frame in the footing holes, and temporarily brace it with props. Fix a track stop into each end of the front sliding door track.

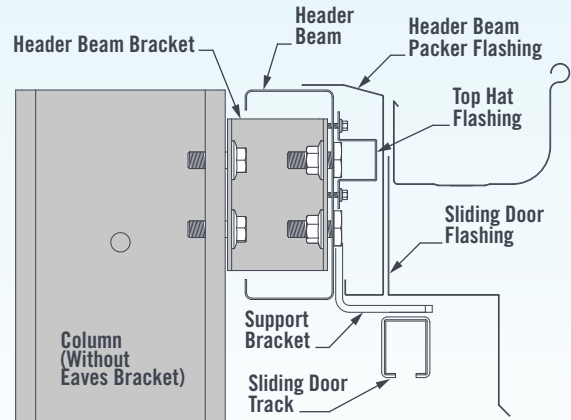


FIGURE 22.10 - TYPE 4 SINGLE SLIDING DOOR

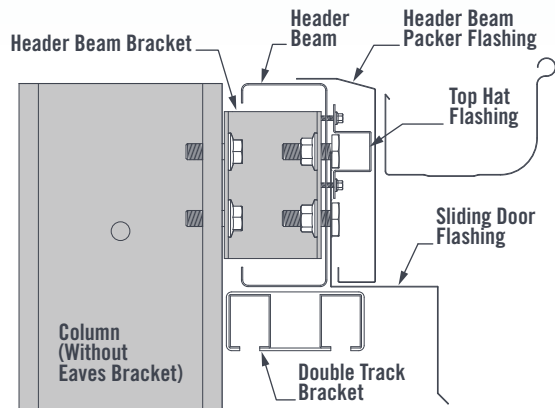


FIGURE 22.11 - TYPE 5/6/7 MULTIPLE SLIDING DOORS

NOTE: WALL SHOWN IS POSITIONED ON THE GROUND BEFORE STANDING INTO PLACE.

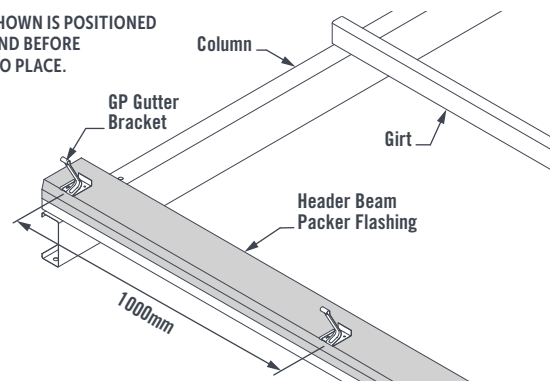
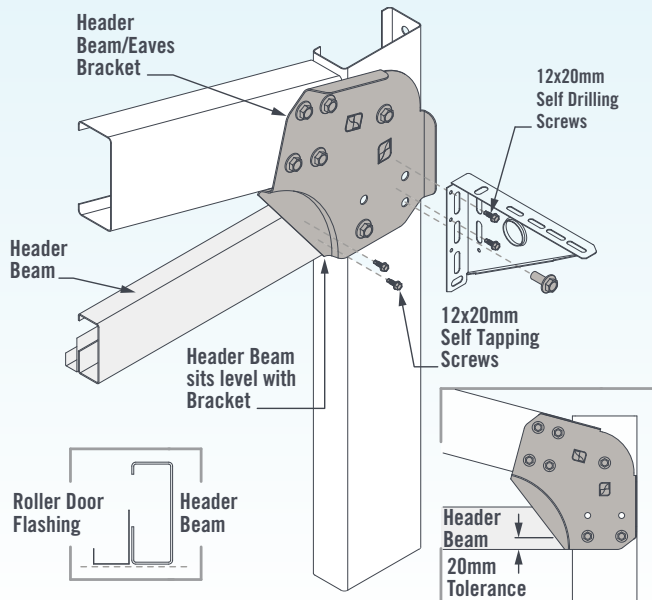


FIGURE 22.12

### 23. ROLLER DOOR INSTALLATION - END WALL

#### TYPE 1 - SINGLE ROLLER DOOR IN END WALL

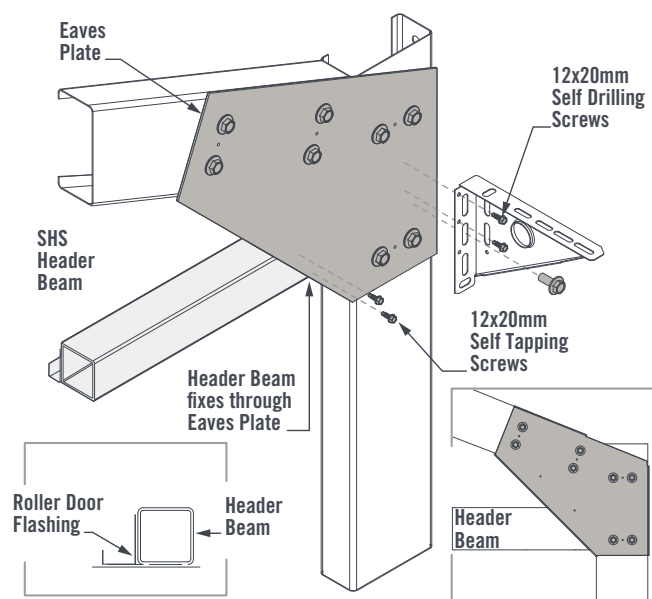
For 15° gable sheds, the header beam will be fixed through the flange of the eave bracket. Clamp the header beam in position while fastening in place with two 12x20mm self drilling screws through each eave bracket flange.



ROLLER DOOR HEADER BEAM ATTACHMENT- 15° PITCH

FIGURE 23.1

For sheds with a roof pitch greater than 15°, an SHS header beam may be supplied in place of the C-Section header, and the eave bracket may be replaced with one or more eave plates as required.



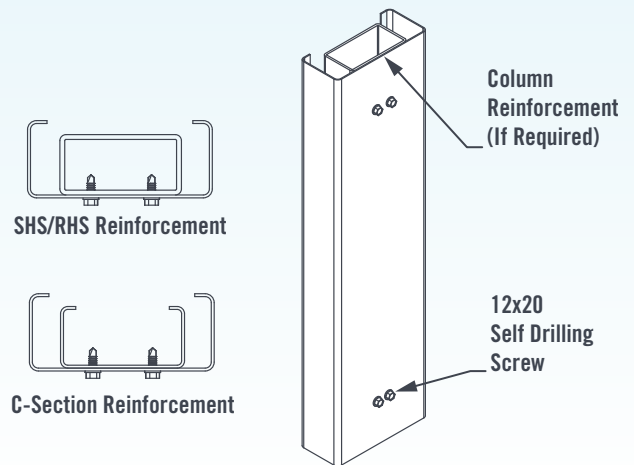
ROLLER DOOR HEADER BEAM ATTACHMENT- ALTERNATIVE PITCH

FIGURE 23.2

#### ROLLER DOOR COLUMN REINFORCEMENT

If reinforcement is required for roller door columns, fix reinforcing with two 12x20 screws spaced 50mm apart, at maximum 450mm intervals along the length of the column. Ensure screws are within 100mm of each end of the reinforcement section. Column reinforcement should run the full length of the column. If the shed will be fixed in ground, the reinforcement should be embedded to the same depth as the column.

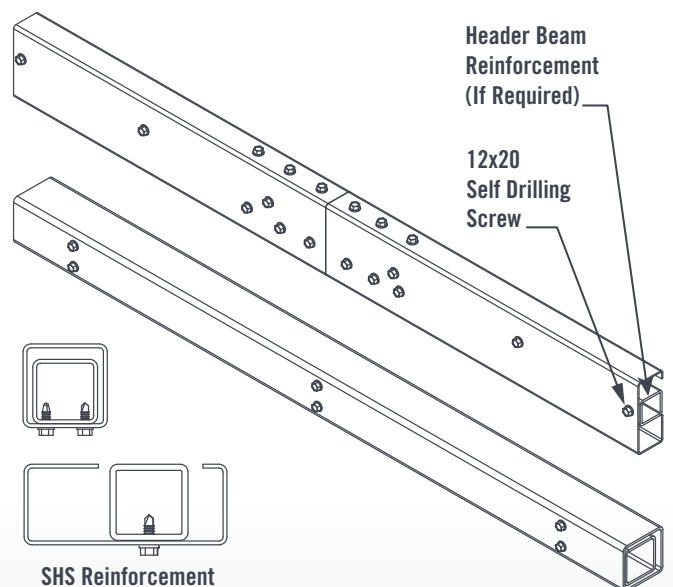
#### ROLLER DOOR HEADER BEAM REINFORCEMENT



ROLLER DOOR COLUMN REINFORCEMENT

FIGURE 23.3

If reinforcement is required for roller door header beams, fix to the header beam with 12x20 screws at maximum 300mm centres (C-Section Header) or with two 12x20 screws spaced 50mm apart at maximum 450mm centres. Ensure screws are within 100mm of each end of the reinforcement section. Reinforcement should run the full length of the header beam.



ROLLER HEADER BEAM REINFORCEMENT

FIGURE 23.4

### TYPE 1 - SINGLE ROLLER DOOR IN END WALL

For sheds with centered roller doors (not full width), additional internal columns are required to support the single roller door. Refer to your design's specs & elevations document for more information.

Attach the header beam to the internal columns with two header beam brackets using 12x20mm screws through each bracket leg. Then install the roller door flashing to the front of the header beam.

Wall girts have been provided to support cladding where required (this will vary depending on your design of shed). Fix girts with girt brackets using 10x16mm self drilling screws and two screws through each bracket leg.

Install the roller door as per the manufacturers specifications.

Pan fix the wall sheets with 10x16mm self drilling screws.

The barge capping and corner flashings can now be installed. Refer to Section 25 for details.

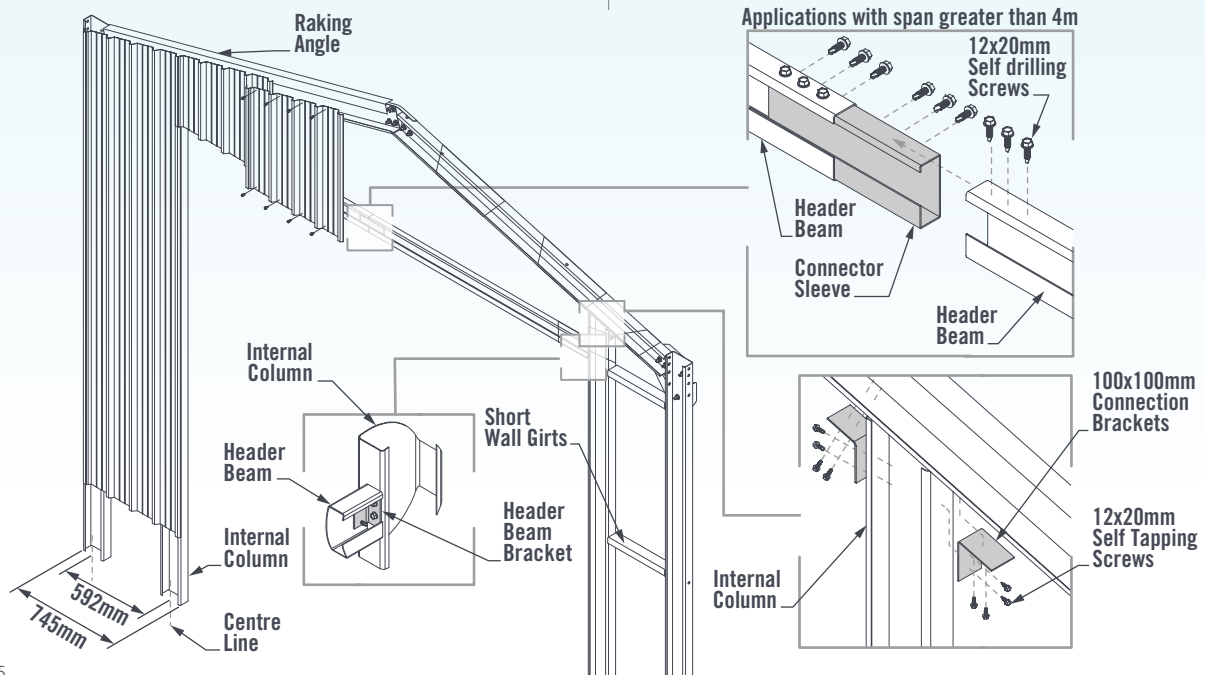


FIGURE 23.5

### TYPE 2 - MULTIPLE ROLLER DOORS IN GABLE END

Sheds with two roller doors in the gable end will generally use a Roller Door Column centered in the end wall. This will usually have at least one reinforcing member - refer to the specifications & elevations document for your shed for further details.

Fix the Centre Roller Door Column to the rafters using two 100x100mm Apex Brackets. Each bracket will be fixed to the column/rafter with two 12x20mm self drilling screws per bracket leg.

The installation of the header beam will follow the same process as for a single roller door, fixing through the flange of the Eaves Connection Bracket (for a 15° shed), or using header beam brackets for other shed designs.

Attach the header beams to the centre roller door column with header beam brackets and two 12x20 screws through each bracket leg, followed by the roller door flashing.

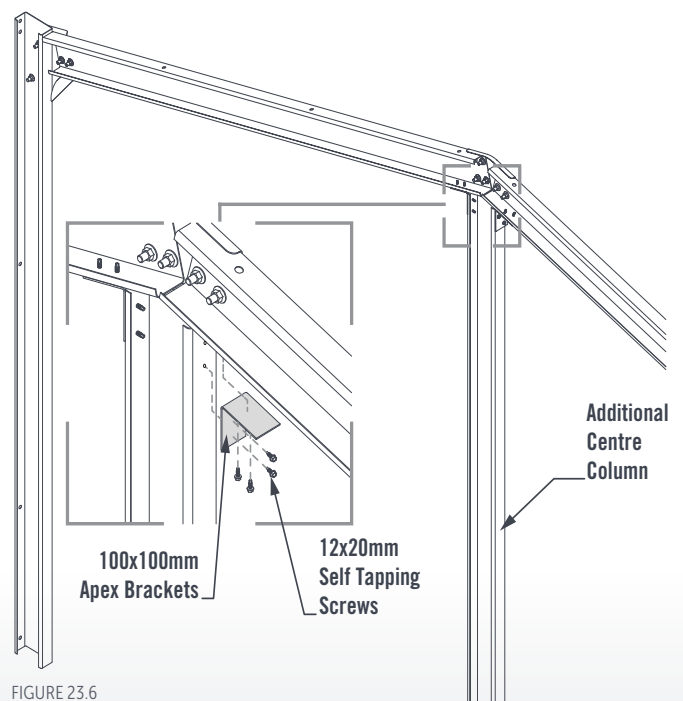


FIGURE 23.6

## TYPE 2 - MULTIPLE ROLLER DOORS IN GABLE END

Install the roller door as per the manufacturers specifications. The roller door brackets are fixed in place sharing one bolt with the eave bracket (for 15° gable sheds) and two additional 12x20mm screws provided. Note, different models of door may have different brackets therefore different fixing requirements.

Rivet the roller door flashing to the front of the header beam, level at the bottom faces. Set the infill sheets into the roller door flashing and pan fix them to the raking angle and header beam with 10x16mm self drilling screws.

The barge capping and corner flashings can now be installed. Fix all flashings with rivets or screw fix (colour 10x16mm) at 600mm centres.

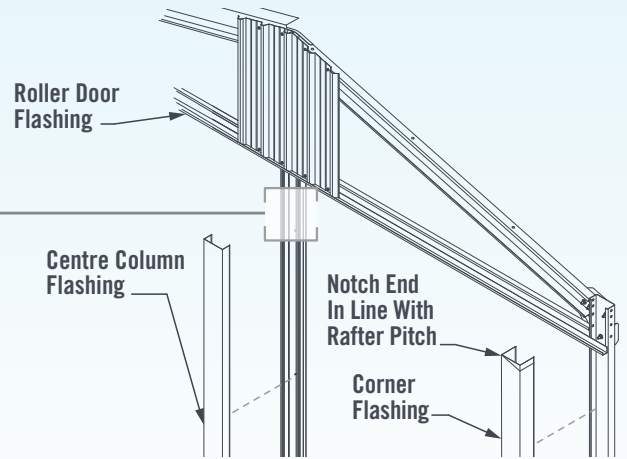
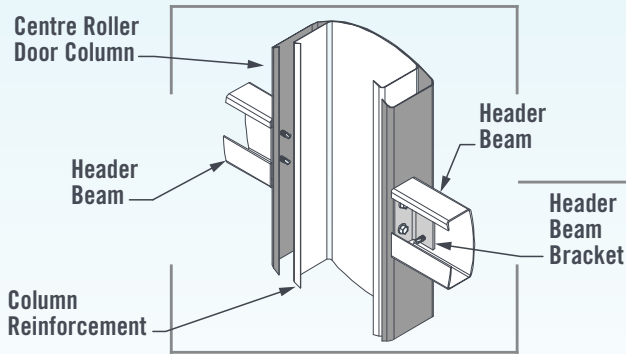


FIGURE 23.7

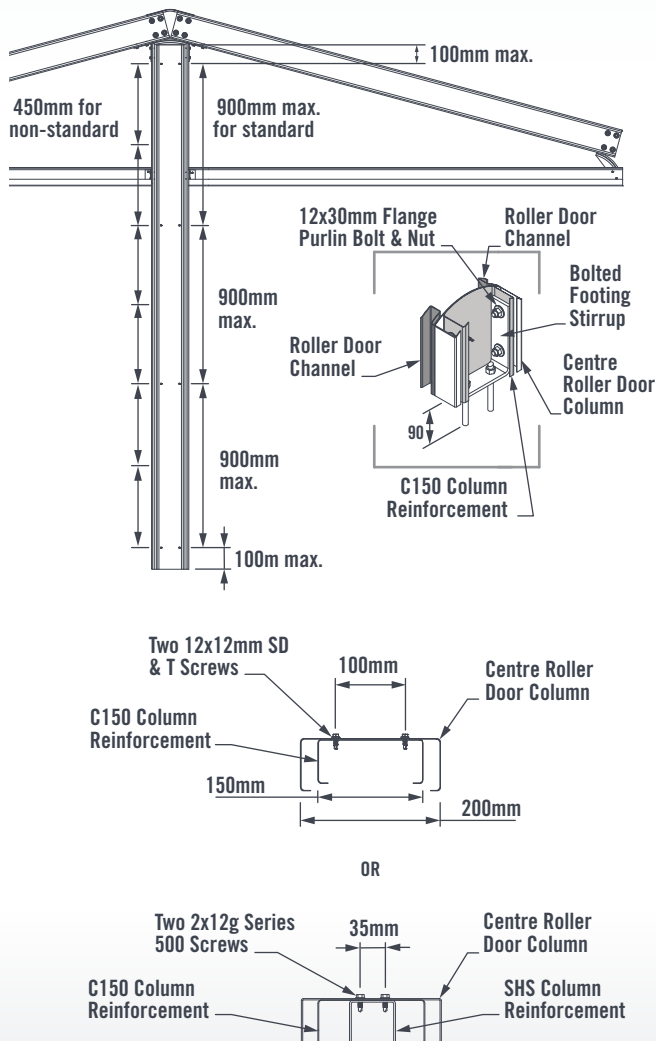


FIGURE 23.8

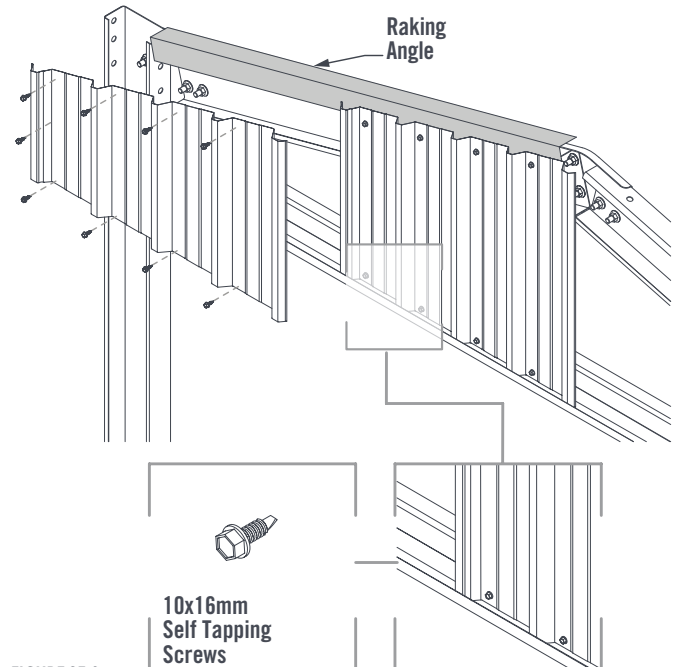


FIGURE 23.9

Note: for sheds with Hiland Tray wall cladding, a raking channel will be used in place of a raking angle. Refer to Section 14 for details.

## 24. SLIDING DOOR INSTALLATION - END WALL

### HEADER BEAM INSTALLATION

The header beam installation process will be the same for both single or double sliding door configurations.

If required, insert the header beam reinforcement section into the sliding door header beam, and fix together with 2x 12x20 self drilling screws at 450mm centres.

For 15° gable sheds, the SHS header and strut may need to be notched. Before attaching the header beam, notch out the required amount of material from the SHS so it can be placed in front of the eaves brackets and fit flush with the front face of the shed columns. When positioned correctly the header beam will provide a flush surface to attach the end cladding as well as locate the header beam at the correct height for the door opening (270mm down from the top of the column).

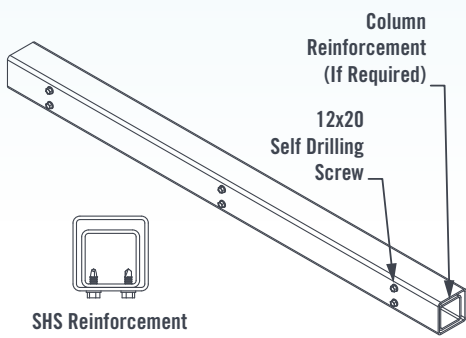


FIGURE 24.1

Use two header beam brackets to attach the header beam to the columns.

Screw the brackets to each column using two 12x20mm self drilling screws then place the header beam on top and use another two 12x20mm self drilling screws through each bracket to secure the header beam in place.

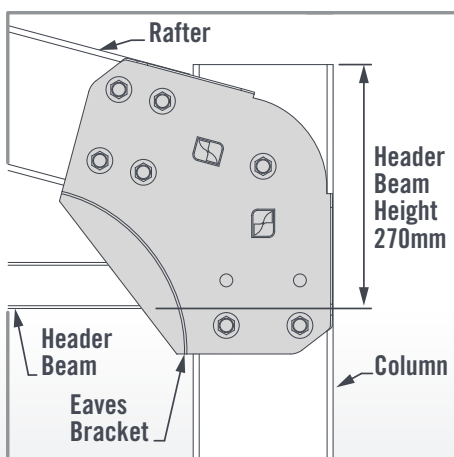


FIGURE 24.2

Notch the top of the vertical strut (for 15° gable sheds only), and fasten strut between rafter(s) and header beam, using 2 12x20mm self drilling screws per bracket leg.

Two header beam brackets are used to connect the strut to the header beam and two apex brackets are used to connect the strut at the apex.

Rivet the sliding door flashing to the SHS header beam then pan fix the end wall sheets with 10x16mm self drilling screws.

The barge capping and corner flashings can now be installed. Refer to Section 25 for details.

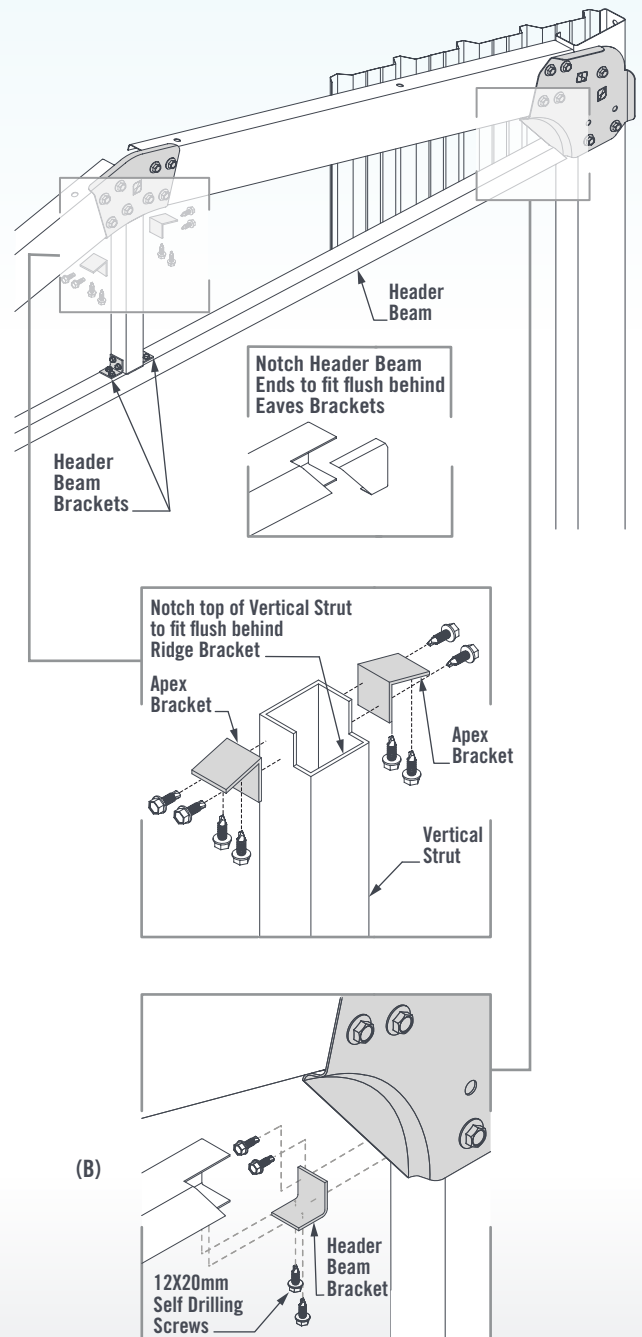


FIGURE 24.3

## MULTIPLE SLIDING DOORS

Push both sliding door tracks through the double brackets and space brackets at 800mm centres. Place the track and brackets on top of the SHS header beam and mark the hole locations for each bracket. Position the end brackets approximately 150mm in from the ends of the tracks. Drill 10mm diameter holes as marked. The inside track may need trimming to fit between the eaves brackets.

Bolt the tracks to the header beam with one M8 hex head bolt per bracket (bolt length will vary to suit SHS size).

Slide two nylon 4 wheel carriages into the end of each sliding door track.

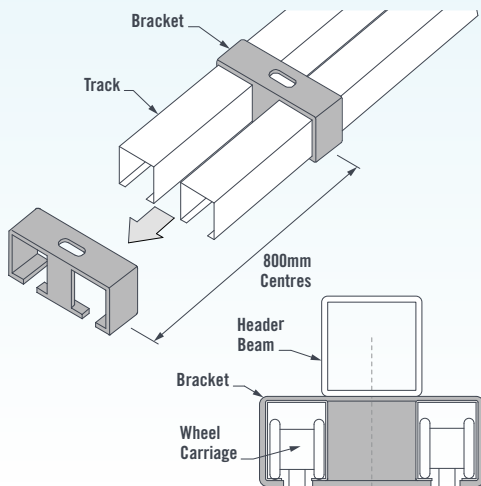


FIGURE 24.4

## SINGLE SLIDING DOOR

Use an M8x12mm counter sunk bolt to fix the support bracket to the track bracket.

Push the sliding door track through the brackets and space the brackets at 800mm centres.

Slide two nylon 4 wheel carriages into the end of each sliding door track.

Fix the sliding door support brackets to the header beam with M10x16mm hex head bolts at 800mm centres.

Position the support bracket so the top face of the bracket is flush with the bottom of the header beam.

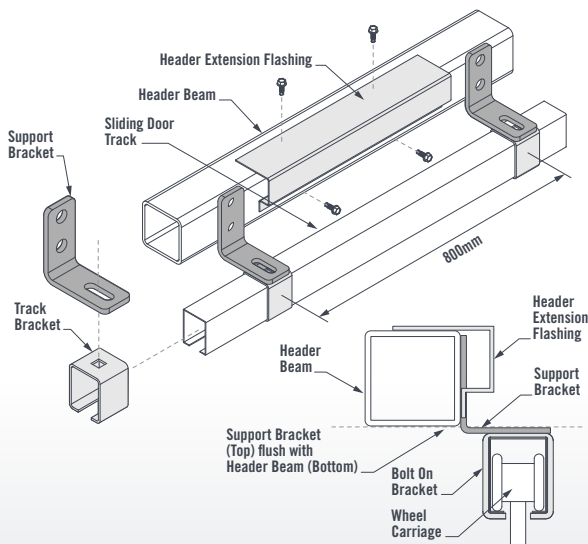


FIGURE 24.5

## HEADER EXTENSION FLASHING

If installing a single sliding door on the Gable End, additional header extension track flashings will be required between every sliding door track support bracket to support the sliding door header flashing and end wall sheets.

Fasten one header beam extension flashing between each support bracket with 12x20 Self Drilling Screws through the front and top face.

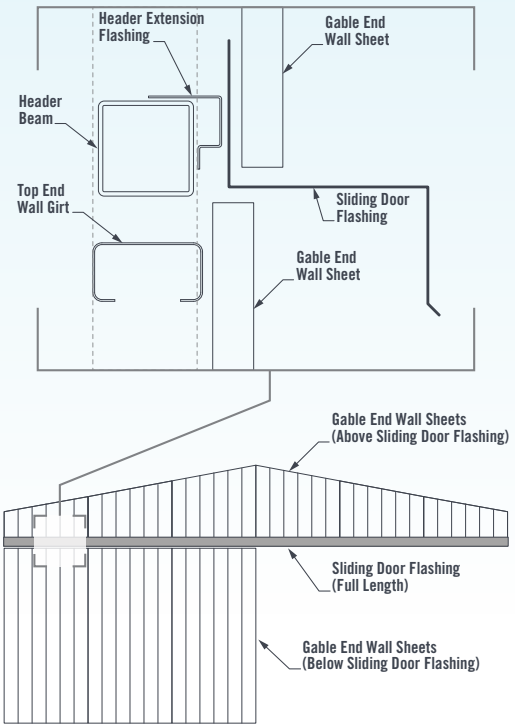


FIGURE 24.6

Rivet the sliding door flashing to the header extension flashing, then pan fix the end wall sheets with 10x16mm self drilling screws.

Additional gable end wall sheets will also be required beside the sliding door opening. Pan fix these gable end sheets to the end wall girts with 10x16 self drilling screws. Note that an additional top end wall girt will be required beneath the header beam to secure the top of the sheets.

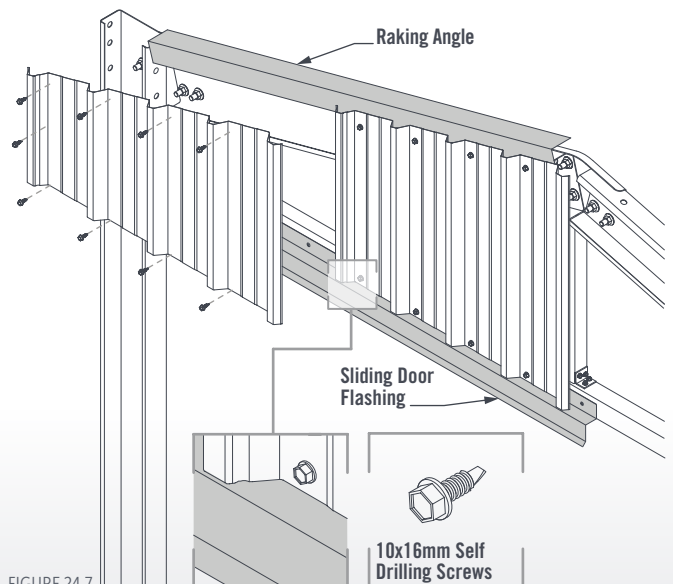


FIGURE 24.7

## 25. FLASHINGS

### STANDARD FLASHINGS

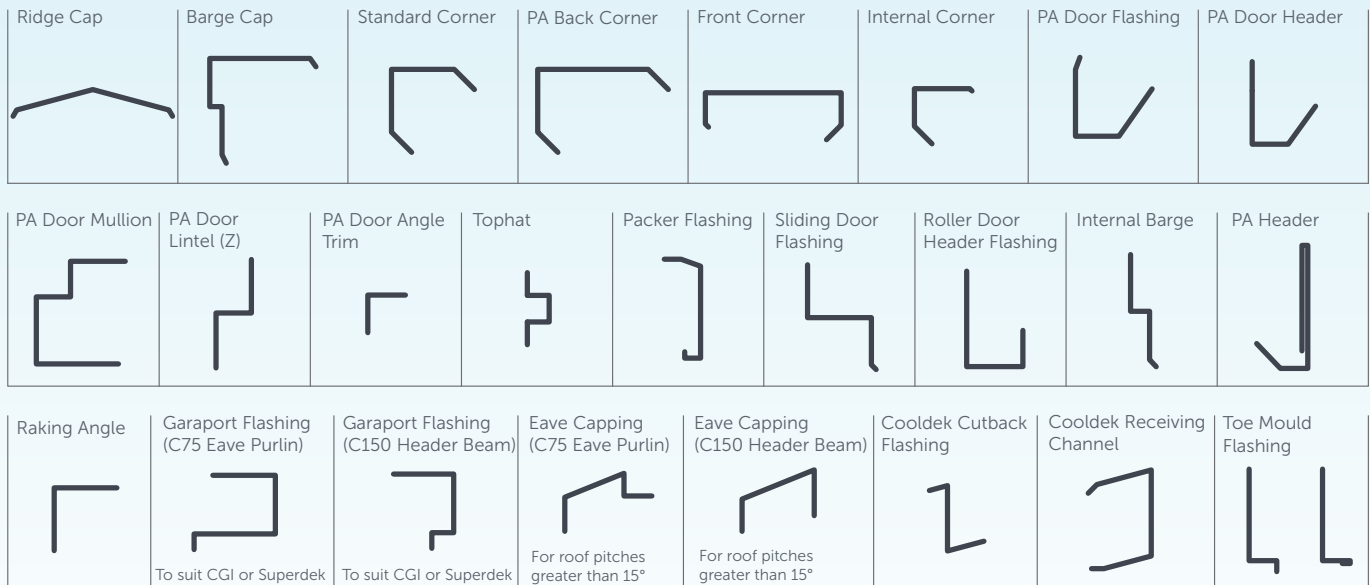


FIGURE 25.1

**Note:** Flashing requirements may differ depending on cladding and shed roof type. Please refer to job-specific drawings for more information.

For sheds with partially open side walls, the Garaport flashing will only run the length of bays without wall sheets. For freestanding Garaports, the Garaport flashing will run the full length of the shed.

### CORNER FLASHING, RIDGE CAP AND BARGE CAP INSTALLATION

Screw the front and rear corner flashings at 600mm centres with 10x16mm self drilling screws. Corner flashings will require notching in line with the rafter pitch.

Fix the front and rear barge capping to the roof sheets. Lap the barges at the ridge line and trim the outside piece to a vertical edge for a neat appearance.

Similarly, fix the ridge capping to the roof sheets with 12x35mm self drilling screws or M6x50 timber/steel screws at 300mm centres.

### HILAND TRAY FLASHINGS

Refer to Section 14 for Hiland Tray installation details. Hiland Tray Barge Cap, Raking Channel, Corner Flashings, Ridge Support, Eave Capping and Garaport Flashings should be installed in conjunction with Hiland Tray cladding.

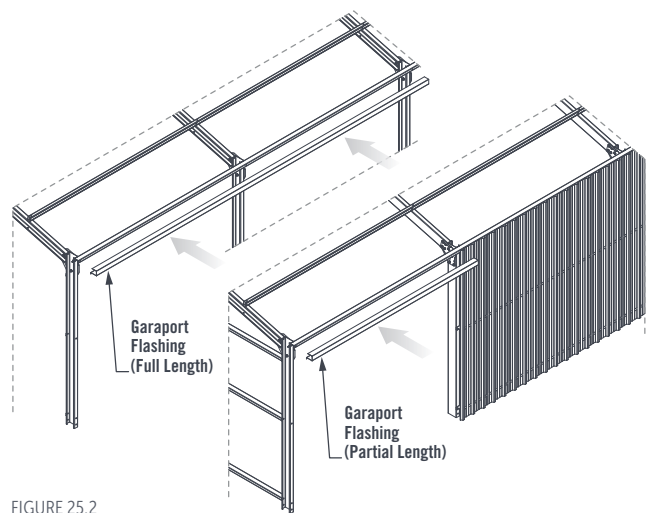


FIGURE 25.2

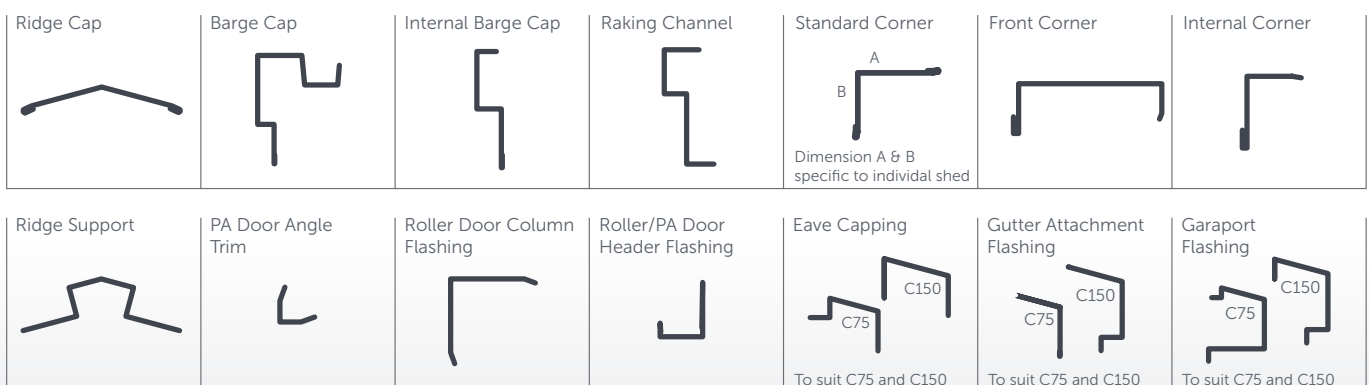


FIGURE 25.3



## 26. MAINTENANCE

Your Stratco Shed will maintain its good looks for even longer with a simple wash and wipe down with a soft broom. Stratco Sheds are produced from the highest quality materials and will provide many years of service if the important recommendations set out in the Stratco 'Selection, Use & Maintenance' brochure are followed. This brochure can be found on the Stratco Website, or via the link in your Order Confirmation Email.



FIGURE 26.1

While the Stratco Selection Use & Maintenance brochure provides comprehensive advice on maintaining your Stratco Shed, it is generally recommended to adhere to the following recommendations.

To maintain the product's surface, wash it with clean water at least every six months. A more frequent wash is recommended in coastal or industrial areas. Maintenance must be frequent enough to prevent dust, salts, pollutants and any other material to accumulate on the product and reduce its life. Products that are regularly washed by rain require no additional maintenance. Avoid locating a Stratco steel product near polluted areas or in areas with aggressive environmental factors that could reduce the life of the steel. This includes areas near barbecues, diesel fumes, air-conditioners, clothes dryers, sprinklers, bore water, water softeners and industrial applications. Stratco steel products and materials are not recommended for use as enclosures for swimming pools or spas.

### WALKING ON ROOFING

On metal roofing, it is important to walk on the purlins. This is both for safety and to avoid damage to the roof. Try to keep your weight evenly distributed and walk flat footed rather than with a heel and toe action. When walking on corrugated iron, spread your weight over as many corrugations as possible. On high profile decking only walk in the pans of the sheet. When delivered, some sheets have an oily film that can be slippery especially when damp. Take extreme care when handling them.



FIGURE 26.2

### WATER PONDING

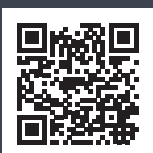
Cleaning of gutters and roofing to avoid a build-up of debris is important to avoid ponding which creates a higher rate of corrosion. Any damage to roofing during a products design life will potentially lead to water ponding so it is recommended damaged sheets are replaced.

### SOIL & GARDEN DEBRIS

Any moisture retaining material such as soil and garden debris must not be placed against Stratco steel products as premature corrosion will occur.

### COLUMN BASE

Any pooling of water around the base of columns will rapidly increase the rate of corrosion so it is important maintenance ensures these areas remains dry (i.e. pooling of water is avoided).



« SCAN THIS QR CODE TO FIND A STRATCO NEAR YOU

**1300 155 155**  
**stratco.com.au**

All brands and logos/images accompanied by © or ™ are trade marks of Stratco (Australia) Pty Limited. © Copyright September 2025

**How To.**

